

## Linear-Transducer LMP48 - CAN

Ref.: K-LMP48-CAN-1

09.04.2014

01020102001006



### Advantages

- Compact construction
- Further interfaces available
- Measures linear movements
- Profile housing
- Wear-free detection

### General Data

Supply	
- Supply voltage	24 VDC $\pm$ 20 %
Measuring principle	magnetostrictive
Measuring length, standard	30...3000 mm, in steps
Resolution	0.05 mm
Linearity deviation	< 0.01 % FS, $\geq$ 60 $\mu$ m
Reproducibility	< 0.005 % FS, $\geq$ 50 $\mu$ m
Straight line velocity	no restrictions
Mounting position	no restrictions
Material - Measuring body	Aluminium extruded profile
Magnet	T1-S3818
	other on request
CAN - Interface	
- Device-Profile	TR specific
- Bus connection	ISO 11898-1, ISO 11898-2
- CAN Specification 2.0 A	11-Bit Identifier
Cycle time internal, $\leq$ 0.50 m	0.50 ms
Cycle time internal, $\leq$ 1.00 m	1.00 ms
Cycle time internal, $\leq$ 1.50 m	1.50 ms

Subject to change.

TR-Electronic GmbH  
Eglishalde 6  
78647 Trossingen  
Tel. +49 (0) 7425 228-0  
info@tr-electronic.de  
[www.tr-electronic.de](http://www.tr-electronic.de)

## Linear-Transducer LMP48 - CAN

Ref.: K-LMP48-CAN-1

09.04.2014

01020102001006

### Environmental conditions

Immunity to disturbance	DIN EN 61000-6-2
Transient emissions	DIN EN 61000-6-3
Working temperature	
- Standard	-20...+75 °C
- Optional	-40...+75 °C;
Storage temperature, dry	-30...+85 °C
Relative humidity	98 %, non condensing
Protection class	
- Standard	IP67
Stray magnetic field	< 3 mT
Measuring reference	Measuring plane

Subject to change.

## Linear-Transducer LMP48 - CAN

Ref.: K-LMP48-CAN-1

09.04.2014

01020102001006

### Dimensional drawing

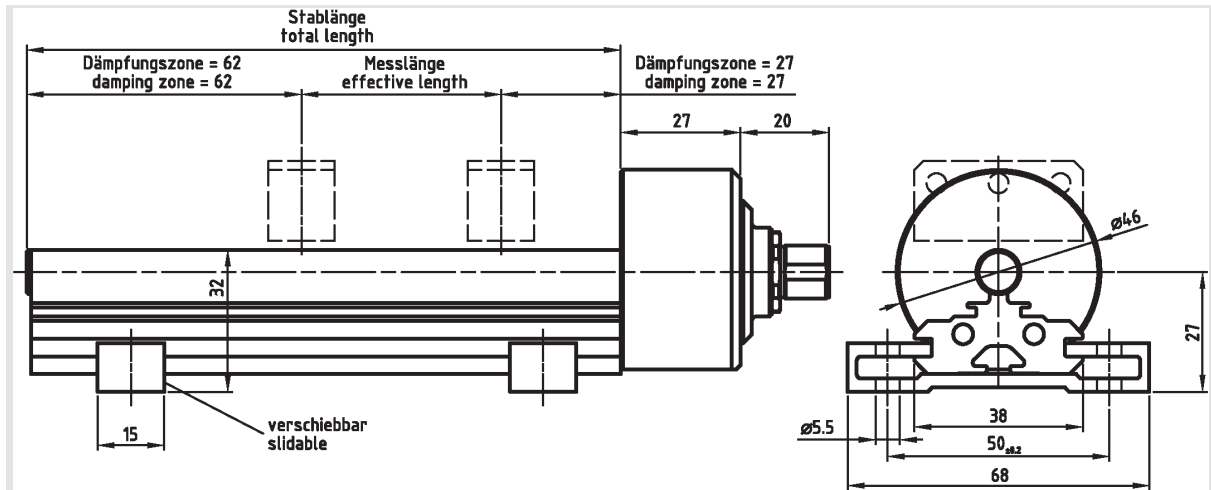

Subject to change.