

## Incremental-Encoder IH 76 (Type 0503 V)

TR-VCE-TI-GB-0631  
04/12 Revision 01  
010101-00769999-9999



- + Incremental interface
- + Type with hollow through shaft  $\varnothing$  16...28 mm
- + Number of pulses per revolution:
  - Version with 9.000 ppr
  - Version with 10.000 ppr
  - Version with 18.000 ppr
- + High accuracy, thus it is applicable as a measuring encoder

### Characteristics

Supply voltage.....	11...27 VDC
5 VDC, $\pm 5\%$ .....	on request
Current consumption without load.....	$\leq 100$ mA
Accuracy	
- Version with 9.000 ppr.....	$\pm 7''$
- Version with 10.000 ppr.....	$\pm 6''$
- Version with 18.000 ppr.....	$\pm 5''$
Interpolation, optional .....	internal 5/10/25/50 times interpolation
Signal outputs .....	Square wave
Outputs (11-27 V level) .....	Push-Pull, short-circuit-proof
- Output current .....	$\leq 20$ mA
- Incremental signal, optional with inverting.....	K1, K2 phase-shifted $90^\circ$ electrically
- Zero-pulse, optional with inverting .....	K0, 1x per revolution, length $90^\circ$ , $180^\circ$ , $360^\circ$ electrically
- Output frequency .....	$\leq 300$ kHz
Outputs (5 V level) .....	Line driver
- Output current .....	$\leq 20$ mA
- Incremental signals, optional with inverting .....	K1, K2 phase-shifted $90^\circ$ electrically
- Zero-pulse, optional with inverting .....	K0, 1x per revolution, length $90^\circ$ , $180^\circ$ , $360^\circ$ electrically
- Output frequency .....	$\leq 1$ MHz
Mechanically permissible speed .....	$\leq 4.000$ min <sup>-1</sup>
Shaft load.....	Own mass
Connection	
- Version with cable outlet .....	radial, cable length on request
- Version with connector .....	radial
Mass.....	approx. 0.5 kg

Subject to change

**Environmental conditions**

Vibration, DIN EN 60068-2-6: 1996 .....	≤ 100 m/s <sup>2</sup> , sine 20-2000 Hz
Shock, DIN EN 60068-2-27: 1995.....	≤ 1000 m/s <sup>2</sup> , half-sine 11ms
EMC	
- Immunity to disturbance, DIN EN 61000-6-2: 2006	
- Transient emissions, DIN EN 61000-6-3: 2007	
Working temperature .....	0 °C...+ 80 °C
Storage temperature .....	- 30 °C...+ 80 °C, dry
Relative humidity, DIN EN 60068-3-4: 2002 .....	98 %, non condensing
Protection class, DIN EN 60529: 1991 *) .....	max. IP 64, dependent on the connector or the connection technique

\*) valid with screwed on mating connector and / or screwed together cable gland

**Dimension drawing**

(For project planning please request customized dimensional drawing!)

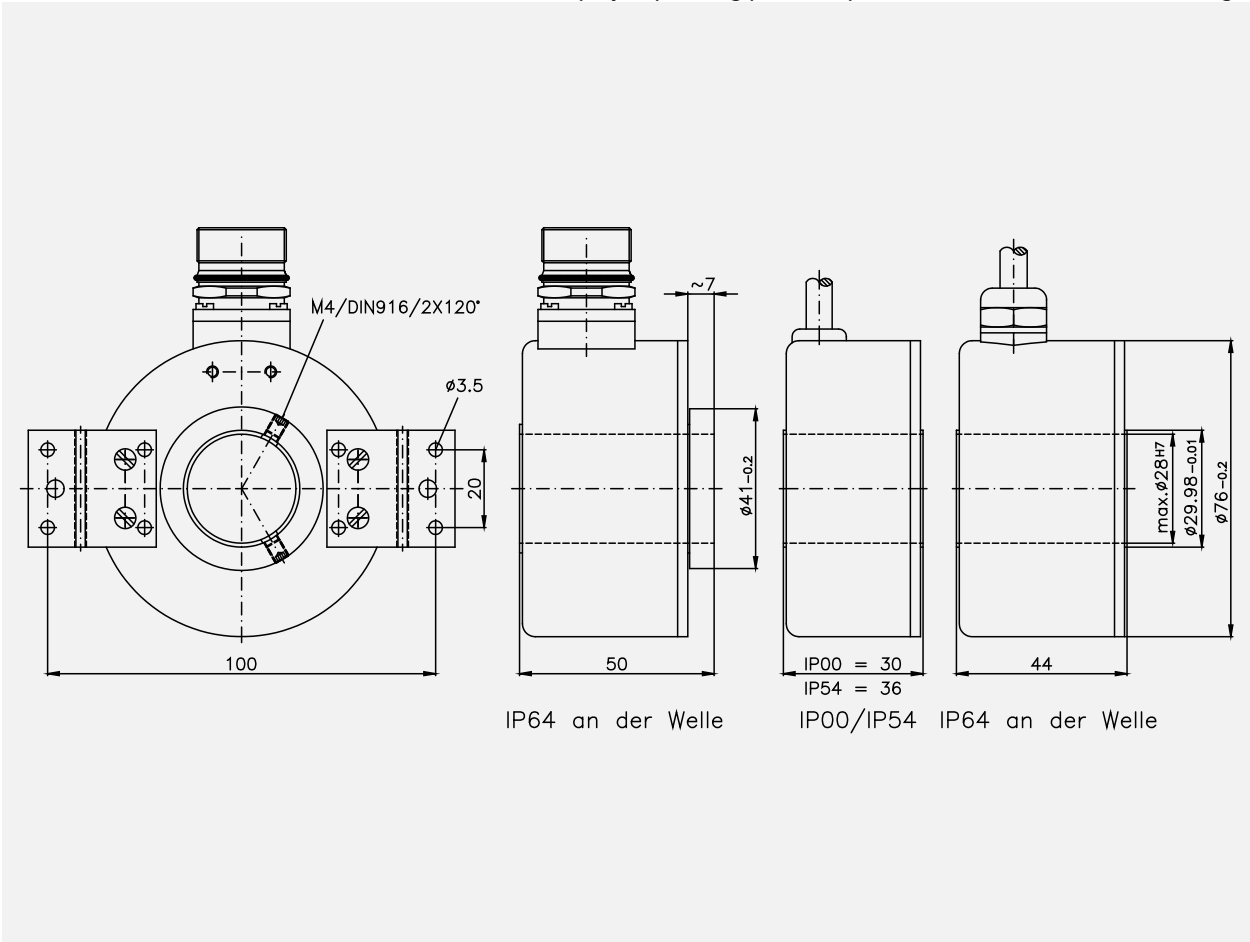

Subject to change