

Rotary
Encoders

Linear
Encoders

Motion

System



LE-200



- Software/Support DVD: 490-01001
- Soft-No.: 490-00416

User Manual

Laser Measuring Device LE-200 with SSI - interface

- [Additional safety instructions](#)
- [Installation](#)
- [Commissioning](#)
- [Configuration / Parameterization](#)
- [Troubleshooting / Diagnostic options](#)



TR-Electronic GmbH

D-78647 Trossingen
Eglishalde 6
Tel.: (0049) 07425/228-0
Fax: (0049) 07425/228-33
E-mail: info@tr-electronic.de
<http://www.tr-electronic.de>

Copyright protection

This Manual, including the illustrations contained therein, is subject to copyright protection. Use of this Manual by third parties in contravention of copyright regulations is forbidden. Reproduction, translation as well as electronic and photographic archiving and modification require the written content of the manufacturer. Offenders will be liable for damages.

Subject to amendments

Any technical changes that serve the purpose of technical progress, reserved.

Document information

Release date/Rev. date: 03/25/2013
Document rev. no.: TR – ELE – BA – GB – 0011 - 04
File name: TR-ELE-BA-GB-0011-04.DOC
Author: MÜJ

Font styles

Italic or **bold** font styles are used for the title of a document or are used for highlighting.

`Courier` font displays text, which is visible on the display or screen and software menu selections.

" < > " indicates keys on your computer keyboard (such as <RETURN>).

Contents

1 General information	6
1.1 Applicability	6
1.2 Abbreviations used / Terminology	7
2 Additional safety instructions	8
2.1 Definition of symbols and instructions	8
2.2 Additional instructions for proper use	8
2.3 Organizational measures.....	9
3 Technical data.....	10
3.1 Electrical characteristics	10
4 SSI information	11
5 Installation / Preparation for commissioning	12
5.1 RS422 Data transmission technology	12
5.2 Connection.....	13
5.2.1 Supply voltage	13
5.2.2 SSI interface	13
5.2.3 Switching input / Switching output	14
5.2.4 RS485 - programming interface.....	14
5.3 General interference suppression measures	15
5.3.1 Connection to the PC (Programming)	16
5.3.2 Wiring examples	17
5.4 SSI interface	18
6 Configuration / Parameter setting via TRWinProg.....	20
6.1 Basic parameter.....	20
6.1.1 Count direction.....	20
6.1.2 Resolution	20
6.1.3 Measuring-Dynamic.....	20
6.1.4 Measuring-Output-Time	21
6.1.5 Physical Resolution.....	21
6.2 SSI interface	22
6.2.1 Number of data bits.....	22
6.2.2 Code.....	22
6.2.3 Fail-Bit SSI	22
6.2.4 Output value SSI.....	22

6.3 Failure-Handling	23
6.3.1 Fail Output	23
6.3.2 Level Fail Output.....	23
6.3.3 Failure-quit	23
6.3.4 Output value in case of an error	24
6.3.5 Warning bit Temperature from.....	24
6.3.6 Warning bit Intensity under	24
6.4 Preset.....	25
6.4.1 Function ext. Input (Switching Input)	25
6.4.2 Active Input-Slope.....	25
6.4.3 Input-Active-Time.....	26
6.4.4 Preset-Value	26
6.4.5 Preset reset.....	26
6.5 Actual values	27
6.5.1 Position	27
6.5.2 Device state	27
6.5.3 Hardware-Info	28
6.6 Speed.....	29
6.6.1 Speed-Values	29
6.6.2 Dynamic	29
6.6.3 Output-Format.....	29
6.6.4 Sign	29

7 Causes of Faults and Remedies 30

Appendix:

Pin Assignment.....	No.: 3296
Drawings	
Dimensioned drawing	04-K2200-005

Revision index

Revision	Date	Index
First release	10/24/03	00
<ul style="list-style-type: none"> • Revision of the laser warning label" 	12/18/03	01
<ul style="list-style-type: none"> • Modification of the Laser Standard DIN EN 60825-1 • Warning bit "Plausibility measured value" • Additional reflector foils • Max. measuring range 240 m • Modification of the parameters 	12/21/07	02
<ul style="list-style-type: none"> • Implementation of new reflectors • Physical resolution = 0,1mm 	02/05/09	03
<ul style="list-style-type: none"> • General changes • Modification of the warnings • Mounting removed 	03/25/13	04

1 General information

This interface-specific User Manual includes the following topics:

- Safety instructions in addition to the basic safety instructions defined in the Assembly Instructions
- Electrical characteristics
- Installation
- Commissioning
- Parameterization
- Cause of faults and remedies

As the documentation is arranged in a modular structure, this User Manual is supplementary to other documentation, such as product datasheets, dimensional drawings, leaflets and the assembly instructions etc.

The User Manual may be included in the customer's specific delivery package or it may be requested separately.

1.1 Applicability

This User Manual applies exclusively to the following measuring system models with **SSI** interface:

- LE-200

The products are labelled with affixed nameplates and are components of a system.

The following documentation therefore also applies:

- the operator's operating instructions specific to the system,
- this User Manual,
- and the assembly instructions **TR-ECE-BA-DGB-0018**, which is enclosed when the device is delivered

1.2 Abbreviations used / Terminology

LE-200	<i>L</i> aser Measuring Device, LE-200 series
CRC	C yclic R edundancy C heck
SSI	S ynchronous- S erial- I nterface
LSB	L east S ignificant B it
MSB	M ost S ignificant B it
T	Period
t_M	SSI mono time
t_p	Pause time
t_D	Delay time
S	Sign
0x	Hexadecimal notation

2 Additional safety instructions

2.1 Definition of symbols and instructions

**WARNING**

means that death or serious injury can occur if the required precautions are not met.

**CAUTION**

means that minor injuries can occur if the required precautions are not met.

NOTICE

means that damage to property can occur if the required precautions are not met.



indicates important information or features and application tips for the product used.

2.2 Additional instructions for proper use

The measuring system is used for recording linear movements and processing the measured data for a downstream control system with a synchronous-serial interface (SSI).

Particularly the measuring system is designed for the use of distance measurements for the detection of the position and positioning of:

- High-bay storage devices and lifting gears
- Crane systems
- Side-tracking skates and truck storage vehicles
- Transfer machines



Proper use also includes:

- observing all instructions in this User Manual,
- observing the assembly instructions. The **"Basic safety instructions"** in particular must be read and understood prior to commencing work.

2.3 Organizational measures

- This User Manual must always be kept accessible at the site of operation of the measurement system.
- Prior to commencing work, personnel working with the measurement system must have read and understood
 - the assembly instructions, in particular the chapter "**Basic safety instructions**",
 - and this User Manual, in particular the chapter "Additional safety instructions".

This particularly applies for personnel who are only deployed occasionally, e.g. at the parameterization of the measurement system.

3 Technical data



The characteristics have validity, only after an operating time of approximate 30 minutes.

3.1 Electrical characteristics

Supply voltage	18 - 27 V DC ($\pm 5\%$)
with heating, optional	24 V DC ($\pm 5\%$)
Current consumption (no-load)	< 350 mA
with heating, optional	< 2.5 A
Measuring principle	Phase delay time measurement
Measuring range (on reflecting foil)	0.2 – 125 m standard, 170 m, 195 m, 240 m (special devices)
	other measuring ranges on request
* Resolution	selectable, physical resolution 0.1 mm
Linearization	
up to 12 m (standard).....	absolute linearity error ± 3 mm
complete measuring length	absolute linearity error ± 5 mm
Reproducibility	± 2 mm
Opto-transmitter	Laser diode (red light)
Wavelength λ	670 nm
Max. laser power.....	$P_{\max} \leq 1$ mW
Laser protection class	2 according to DIN EN 60 825-1: 2003-10
Lifetime	50 000 h
Measured value output / refresh cycle ...	1000 values / s
Integration time	1 ms
Programming via RS485	WINDOWS® compatible (TRWinProg) / Profibus-DP
SSI Interface:	Clock/Data, twisted pair cables and shielded
Clock input:	Optocoupler
Clock frequency:	80 kHz - 820 kHz
* Output code:.....	Binary, Gray
* SSI output value:	Position, Intensity, Speed
Cable length:.....	Depending on cable cross section, shielding, clock frequency etc.
Data output:	RS422 (4-wire)
* Number of data bits:	12-26, with error bit transmission
	(Temperature, Intensity, Hardware)
* Switching input/output	
Levels switching input	1 level > +8 V, 0 level < +2 V, up to ± 35 V, 5 kOhm
Levels switching output	1 level > US-2 V, 0 level < 1 V, up to 100 mA
EMC	
Immunity to disturbance	DIN EN 61000-6-2: 2006
Transient emissions	DIN EN 61000-6-3: 2007

* programmable parameter

4 SSI information

The SSI procedure is a synchronous serial transmission procedure for the measuring system position. By using the RS422 interface for transmission, sufficiently high transmission rates can be achieved.

The measuring system receives a clock sequence from the control and answers with the current position value, which is transmitted serially and is synchronous to sent clock.

Since the data transfer is synchronized by the start of the sequence, it is not necessary to use single-step codes such as Gray code.

The data signals Data+ and Data- are transmitted by means of cable transmitters (RS422). The clock signals Clock+ and Clock- are received by means of optocouplers to protect them from damage resulting from interference, potential differences, or polarity reversal.

Parity bits or checksums can be added to detect faulty transmissions. The simplest measure is to read in the values twice with the data bits being repeated after 26 clock pulses of a sequence. However, this has the disadvantage of considerably increasing transmission times.

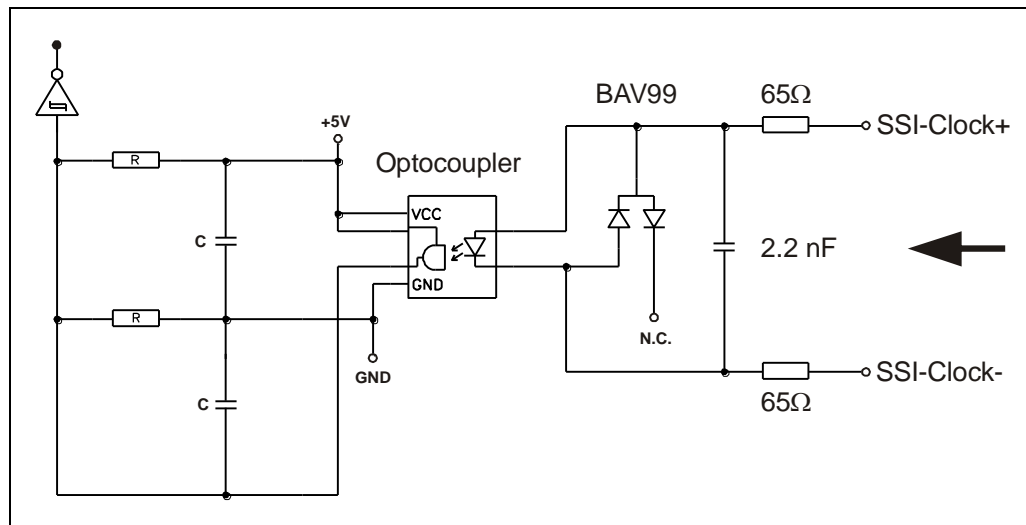

Figure 1: SSI Principle input circuit

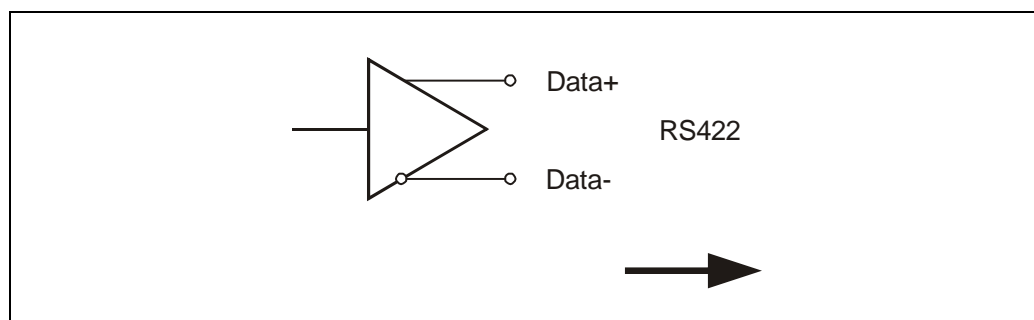

Figure 2: SSI Output circuit

5 Installation / Preparation for commissioning

5.1 RS422 Data transmission technology

With the RS422 transmission one line-pair is used for the signals Data+ and Data– and one line-pair for the signals Clock+ and Clock–.

The serial data are transmitted without mass reference as a voltage difference between two corresponding lines.

The receiver evaluates only the difference between the two lines. Therefore common-mode interferences on the transmission line do not lead to a corruption of the useful signal.

By the use of shielded and twisted pair cable, data transmissions over distances from up to 500 meters with a frequency of 100 kHz can be realized.

Under load RS422 transmitters provide output levels of $\pm 2V$ between the two outputs. RS422 receivers still recognize levels of $\pm 200mV$ as valid signal.

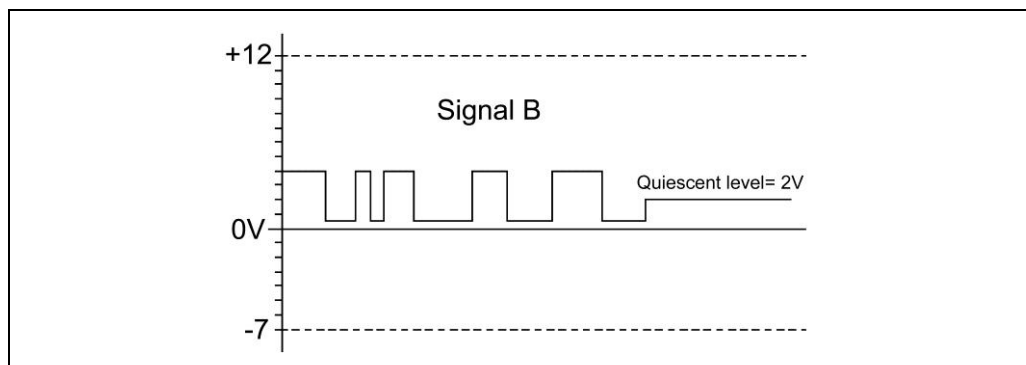
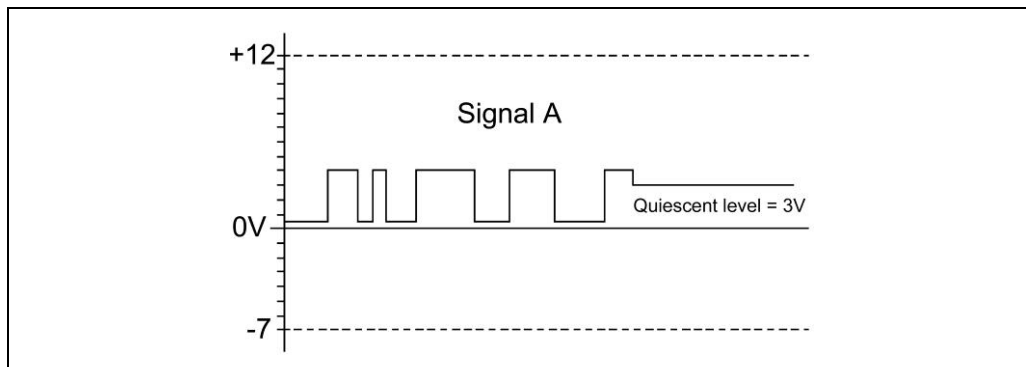
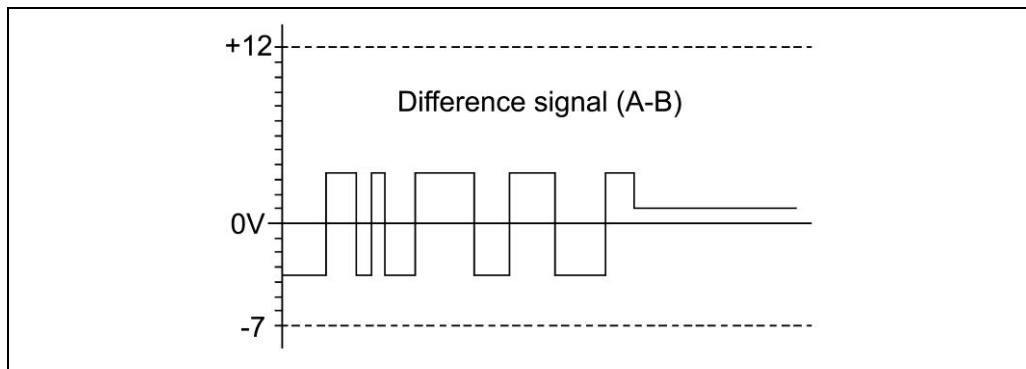

5.2 Connection

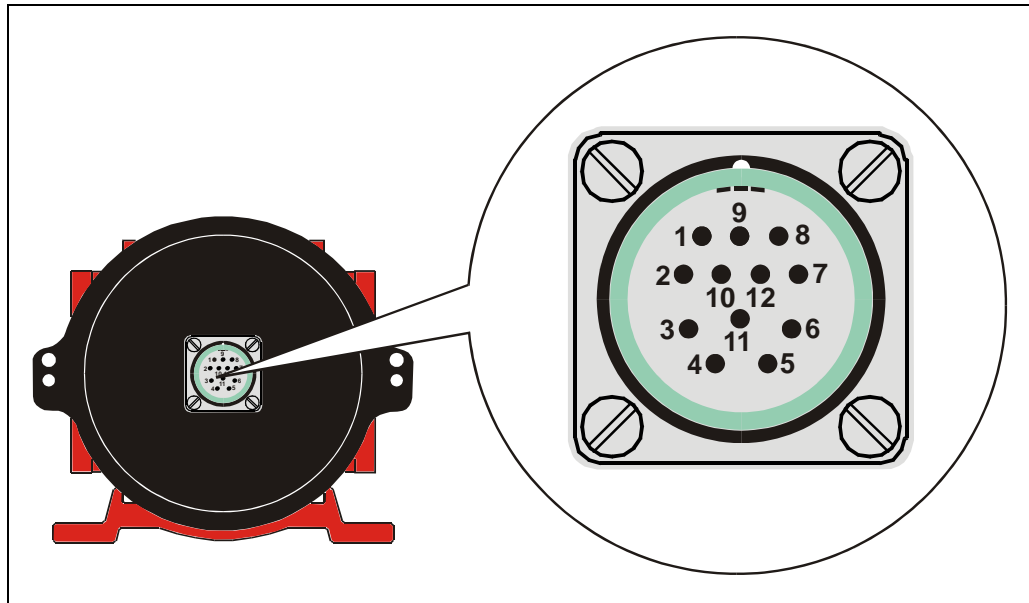

5.2.1 Supply voltage

Pin 11 Standard: 18 – 27 V DC
Device with heating: 24 V DC ($\pm 5\%$)

Pin 12 0V, GND

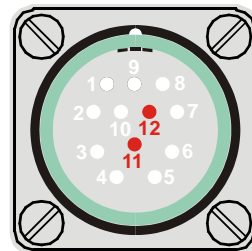

5.2.2 SSI interface

Pin 1 SSI-Clock –

Pin 2 SSI-Clock +

Pin 3 SSI-Data +

Pin 4 SSI-Data –

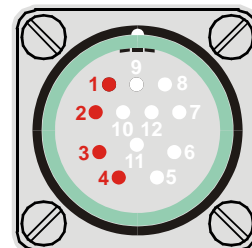

5.2.3 Switching input / Switching output

The programming of the switching input /switching output is carried out directly via the PC software "TRWinProg".

Functions of the switching input:

- Preset
- Switch off laser diode
- Failure quit

Functions of the switching output:

- Temperature
- Intensity
- Hardware-Fail
- every fail
- Speed-check
- Plausibility measured value
- Switching output position

Pin 8 Switching output

Pin 9 Switching input

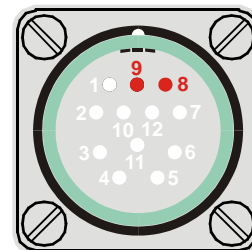

5.2.4 RS485 - programming interface

Via the PC software "TRWinProg" and a PC adapter the connection to the laser measuring device is established. More information's see page 15 or in the TRWinProg software manual.

Pin 5 RS485+

Pin 6 RS485-

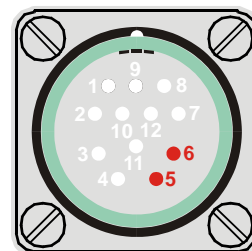

5.3 General interference suppression measures

- Lay the (shielded) connecting cable to the device at a sufficient distance or in a separate room from any power cables which are subject to interference. Otherwise the data transmission of the measured value can be interfered.
- To ensure reliable data transmission, use fully shielded cables and make sure they are well earthed. For differential data transfer (RS422, RS485 etc.), twisted-pair wires must be used in addition.
- Use a minimum cable cross-section of 0.25 mm^2 for the SSI-signals data+/- and clock +/-.
- Use a minimum earthing cable (machine base) cross-section of 10 mm^2 in order to avoid equipotential currents across the shield. Make sure the resistance of the earthing cable is much lower than that of the shield.
- Avoid crossing cables where possible. If unavoidable, only cross them at right-angles.
- Ensure continuous wiring of the shield and a large contact area on special cable screw glands (mating connector, female connector):

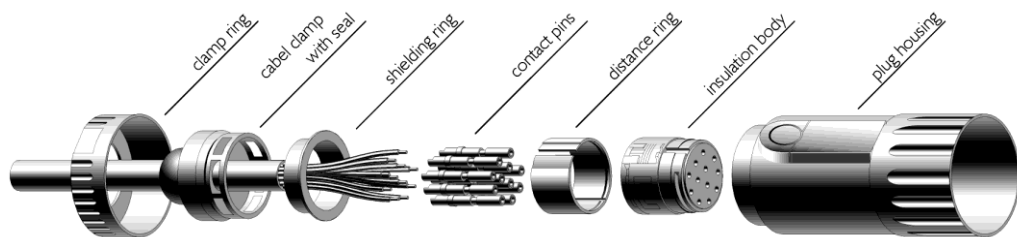

Step A:

- 1.-2. Push clamp ring and cable clamp with seal over cable. (If required insert sleeve order no. FC6CX004I00X is helpful)
3. Strip cable 24mm.
4. Push shielding back over cable.

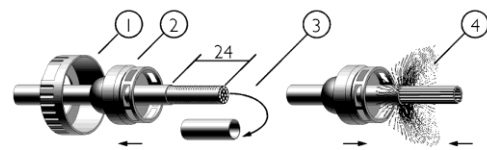

Step B:

5. Strip cores 5mm.

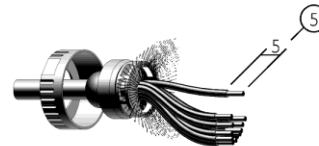

Step C:

6. Put shielding ring on.
7. Twist remaining shielding around shielding ring.

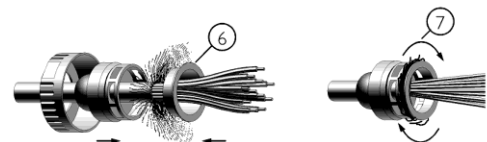

Step D:

8. Solder wires in contacts.

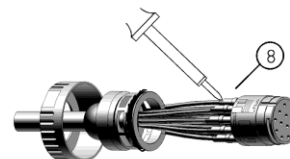

Step E:

9. Snap distance ring over insulation body.
10. Push insulation body into bridge of plug housing.

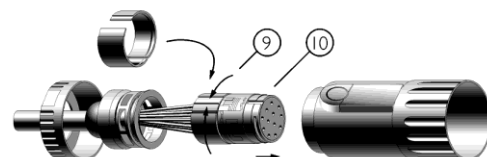

11. Screw clamp ring onto plug housing.

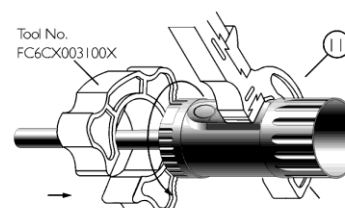

5.3.1 Connection to the PC (Programming)

What will be needed by TR-Electronic?

- **Switch cabinet module Order-No.: 490-00101**

- **Programming set Order-No.: 490-00310:**
 - **Plastic case,**
with the following components:
 - USB PC adapter V4
Conversion USB <--> RS485
 - USB cable 1.00 m
Connection cable between
PC adapter and PC
 - Flat ribbon cable 1.30 m
Connection cable between
PC adapter and TR switch cabinet module
(15-pol. SUB-D female/male)
 - Plug Power Supply Unit 24 V DC, 1A
The connected device can be supplied via the PC adapter
 - Software- and Support-CD
 - USB driver, Soft-No.: 490-00421
 - TRWinProg, Soft-No.: 490-00416
 - EPROGW32, Soft-No.: 490-00418
 - LTProg, Soft-No.: 490-00415
 - Installation Guide
TR-E-TI-DGB-0074, German/English

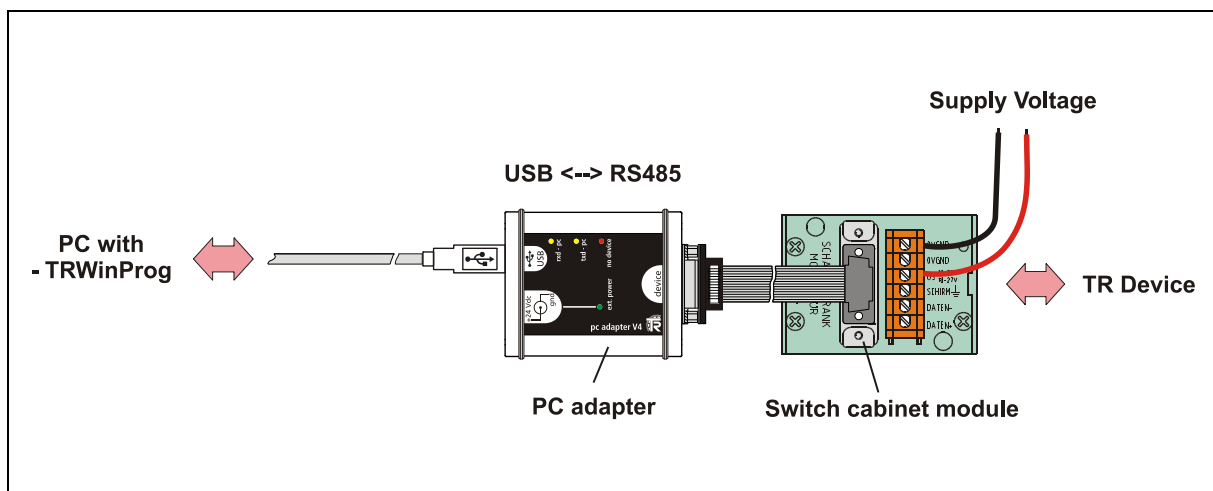

5.3.2 Wiring examples

* Shield connection, see chapter General interference suppression measures page 15.

RS485 / SSI - connection with parameter setting via "TRWinProg"

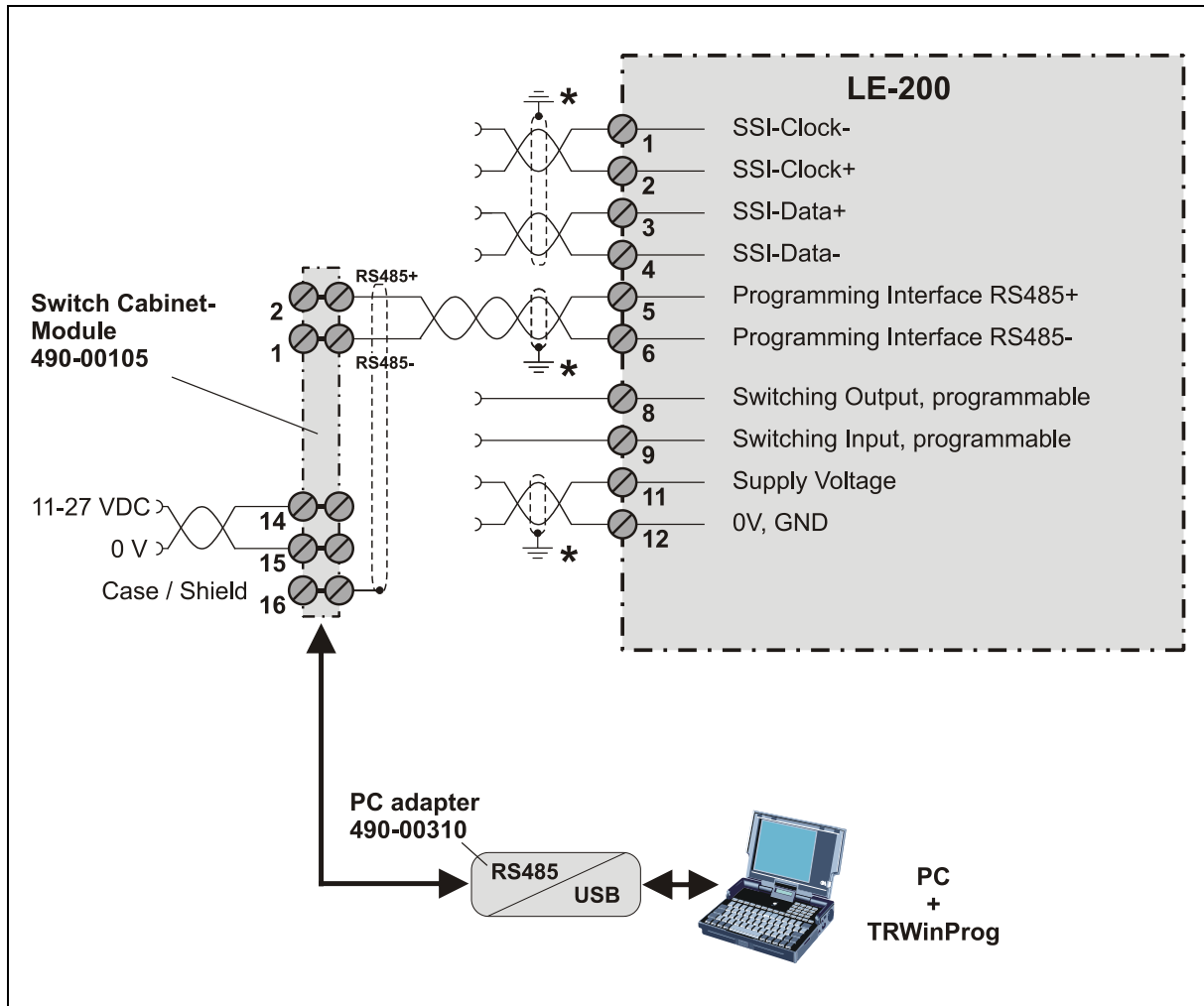

5.4 SSI interface

In the idle condition the signals Data+ and Clock+ are high. This corresponds the time before item **1** is following, see chart indicated below.

With the first change of the clock pulse from high to low **1** the internal-device-monoflop (can be retriggered) is set with the monoflop time t_M .

The time t_M is set to 20 μs and determines the lowest transfer frequency of approximately 80 kHz. The upper limit frequency results from the total of all the signal delay times and is limited additional by the built-in filter circuits to approx. 820 kHz.

With each further falling clock edge the active condition of the monoflop extends by further 20 μs , at last at item **4**.

With setting of the monoflop **1**, the bit-parallel data on the parallel-serial-converter will be stored via an internal signal in the input latch of the shift register. This ensures that the data cannot change during the transmission of a position value.

With the first change of the clock pulse from low to high **2** the most significant bit (MSB) of the device information will be output to the serial data output. With each following rising edge of the clock pulse, the next lower significant bit is set on the data output.

When the clock sequence is finished, the system keeps the data lines at 0V (Low) for the duration of the mono period, t_M **4**. With this, the admissible break time t_p between two successive clock sequences is determined and is $>20\mu s$.

Caused by the delay time t_v (approx. 100ns, without cable), the evaluation electronic must be read-in the data only at time **3**. This corresponds to the second rising clock edge. For this reason the number of clock pulses corresponds the number of data bits +1.

Typical SSI - transmission sequences

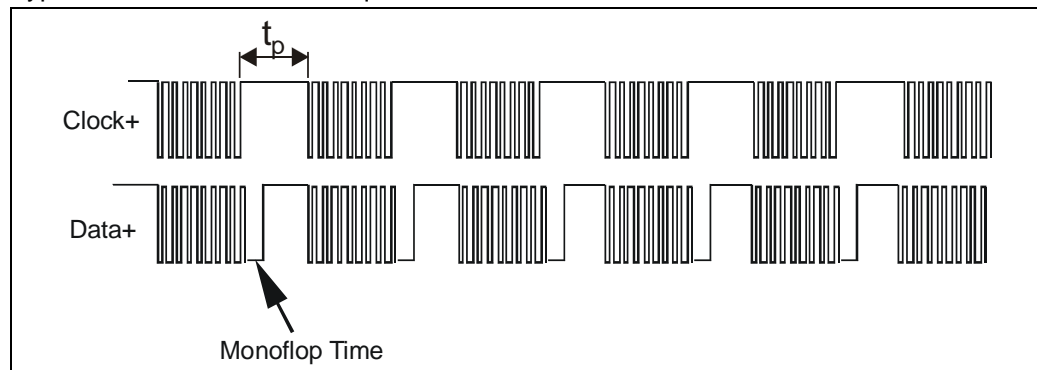

SSI transmission format

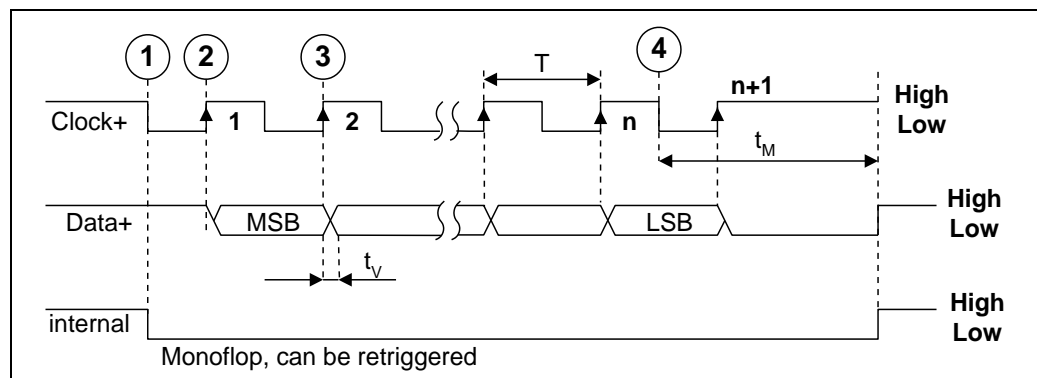

The maximum cable length depends on the SSI clock frequency and should be conditioned to the following diagram.

Pay attention, that per meter cable with an additional delay-time of approx. 6ns must be calculated.

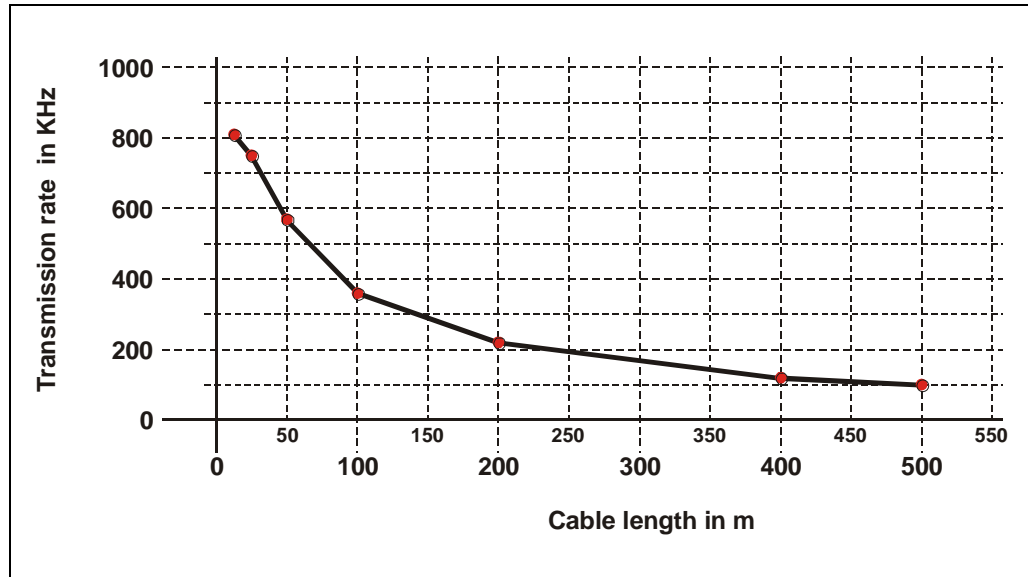

Cable length [m]	SSI-clock frequency [kHz]
12,5	810
25	750
50	570
100	360
200	220
400	120
500	100

6 Configuration / Parameter setting via TRWinProg

6.1 Basic parameter

6.1.1 Count direction

The counting direction defines whether increasing or decreasing position values are output.

Selection	Description	Default
Up	With increasing distance to the laser, values increasing	X
Down	With increasing distance to the laser, values decreasing	

6.1.2 Resolution

Definition of the measuring system resolution.

Selection	Default
10 mm	
1 mm	X
1/10 mm	
1/100 mm	
1 Inch	
1/10 Inch	
1/8 mm	
Free resolution (in 1/100 mm), valid values are 1 - 65535 For example 1 mm corresponds the input value of 100. That means the laser outputs 1 step/mm.	100

6.1.3 Measuring-Dynamic

Measuring-dynamic is an parameter, who characterize mathematic calculation of the measure-value. With high measuring-dynamic there is no mathematic calculation on the measure-value, but the noise of the measure-value is larger, in case of small measuring-dynamic the noise is lower, but there exist a small time-delay for the measure-value.

Selection	Default
slow	
mid	X
high	

6.1.4 Measuring-Output-Time

The Measuring-Output-Time defines the time for calculating the measuring value.

Selection	Default
1 ms	X
2 ms	
3 ms	
4 ms	
5 ms	
6 ms	
7 ms	
8 ms	
9 ms	
10 ms	
15 ms	
20 ms	
25 ms	
30 ms	
50 ms	
100 ms	
200 ms	
500 ms	

6.1.5 Physical Resolution

The physical resolution of the measuring system is the smallest possible resolution, with which the measured value can be produced.

Selection	Default
0.76 mm	X
0.1 mm	

6.2 SSI interface

6.2.1 Number of data bits

The number of data bits defines the max. number of data bits which can be transferred on the SSI interface. A possibly defined error bit is not contained.

Selection	Description	Default
12 bit	Number of SSI data bits = 12	
---	---	
24 bit	Number of SSI data bits = 24	X
25 bit	Number of SSI data bits = 25	
26 bit	Number of SSI data bits = 26	
27 bit	Number of SSI data bits = 27	
28 bit	Number of SSI data bits = 28	
29 bit	Number of SSI data bits = 29	
30 bit	Number of SSI data bits = 30	
31 bit	Number of SSI data bits = 31	
32 bit	Number of SSI data bits = 32	

6.2.2 Code

Defines the SSI output code.

Selection	Description	Default
Gray	SSI output code = Gray	X
Binary	SSI output code = Binary	

6.2.3 Fail-Bit SSI

The SSI error bit is an additional bit in the SSI protocol and is attached after the "LSB-bit". Definition of errors see "Device state", page 27.

Selection	Default
disabled	X
Temperature	
Intensity	
Hardware	
Every Failure	
Plausibility measured value	

6.2.4 Output value SSI

The SSI output value specifies the value, which is output on the SSI interface.

Selection	Description	Default
Position	Output of the Laser position	X
Intensity	Output of the Laser intensity value	
Speed	Output of the Laser actual speed	
Position + Speed	21 bit position data, 11 bit speed. The number of data bits must be set to 32. Max. possible resolution = 0.1 mm.	

6.3 Failure-Handling

6.3.1 Fail Output

Determines the function of the error output (external switching output). Definition of errors see "Device state", page 27.

Selection	Default
disabled	X
Temperature	
Intensity	
Hardware-Fail	
every fail	
Speed-check	
Plausibility measured value	
Switching output position	

6.3.2 Level Fail Output

Specifies the active output level of the selected error, if the error occurs.

Selection	Description	Default
active HIGH	Error active, Switching Output = HIGH	X
active LOW	Error active, Switching Output = LOW	

6.3.3 Failure-quit

Determines, whether occurring error reports should be cleared automatically after eliminating the trouble.

Selection	Description	Default
automatic	An occurring error report is cleared automatically after remedying of the error.	X
not automatic	An occurring error report can be cleared only via the external switching input (see "Function ext. Input (Switching Input)", page 25).	

6.3.4 Output value in case of an error

Determines, which data value is to be transmitted in the case of an error. The data value is output, if the laser can output no more measurement. This is given e.g., if a beam interruption is present.

Selection	Description	Default
all 0	The position is set to "0"	X
all 1	All 24 bits are set to '1' (0xFFFFFFFF or -1)	
last valid value	Output of the last valid position	

6.3.5 Warning bit Temperature from

Determines, starting from which temperature the warning bit or switching output will be set.

Selection	Description	Default
47	Message, if device temperature ≥ 47 °C	
48	Message, if device temperature ≥ 48 °C	
49	Message, if device temperature ≥ 49 °C	
50	Message, if device temperature ≥ 50 °C	X

6.3.6 Warning bit Intensity under

Determines, starting from which intensity value of the laser beam the warning bit or switching output will be set.

Input	Description	Default
1 – 100 [%]	Message, if intensity value < Input value	12 %

6.4 Preset

6.4.1 Function ext. Input (Switching Input)

⚠ WARNING

Risk of injury and damage to property by an actual value jump when the Preset function is performed!

NOTICE

- The *preset function* should only be performed at rest, otherwise the resulting actual value jump must be permitted in the program and application!

Determines, whether the switching input is to be used as

- Preset input
- Switch-off Laser-Diode (LD) or
- Failure reset - input

With connection of the switching input as Preset-input the laser is adjusted on the predefined position value in chapter "Preset-Value", page 26. With connection the switching input as LD-input the laser diode is switched off for the extension of the life time. If in the PC-program "TRWinProg" in the basic parameters the switching-off of the laser diode is carried out automatically, the LD-switching input does not have a function.

Selection	Description	Default
disabled	Function switched off, following parameters without meaning.	X
Preset function	External switching input is determined as Preset input.	
LD switching input	External switching input is used for switching-off of the laser diode.	
Error acknowledgement	External switching input is used as error acknowledgement.	

6.4.2 Active Input-Slope

It determines whether the function of the switching input is activated with an rising or falling edge at the switching input.

Selection	Description	Default
Low->High	Function release with rising edge	X
High->Low	Function release with falling edge	

6.4.3 Input-Active-Time

It determines the response time of the switching edge of the switching input up to the actual execution. This parameter is used for the interference suppression of the signal at the switching input.

Selection	Description	Default
100 ms	Response time = 100 ms	X
200 ms	Response time = 200 ms	
500 ms	Response time = 500 ms	
1000 ms	Response time = 1000 ms	

6.4.4 Preset-Value

Definition of the position value to which the laser is adjusted, when the preset function is executed (see "Function ext. Input (Switching Input)", page 25).
 The preset value must be programmed in the range from 0 ... measuring length (see "Range", chapter "Technical data", page 10). **Default value is "0"**.

6.4.5 Preset reset

⚠ WARNING

Risk of injury and damage to property by an actual value jump when the clear preset function is performed!

NOTICE

- The *clear preset function* should only be performed at rest, otherwise the resulting actual value jump must be permitted in the program and application!

Via this parameter, the calculated zero-point is deleted (difference of the desired preset value to the physical laser position). After deletion of the zero-point correction the laser outputs his "real" physical position. With the adjusting = "Yes" no Preset/Adjustment can be executed.

Selection	Description	Default
Yes	Clear Preset	X
No	No clearing	

6.5 Actual values

In this tab all required operation parameters will be displayed:

- Position, with the resolution adjusted in the basic parameters
- Intensity [%]
- Device-Temperature [°C]
- Speed, with the output format adjusted in the speed parameters
- Device state
- Hardware-Info

6.5.1 Position

By writing of a value into the field position the laser can be adjusted on the desired position value. The execution is carried out with transmission of the values to the laser measuring device.

The value must be programmed in the range from 0 ... measuring length (see "Range", chapter "Technical data", page 10).

6.5.2 Device state

The device state displays the actual state of the device and is coded bitwise:

Error-Code	Description
Intensity Bit 0	The bit is set, if an intensity value of smaller 8% is present, or the laser beam is interrupted and leads to the error value output (see chapter "6.3.4", page 23).
Temperature Bit 1	The bit is set, if the device temperature is outside of the range from 0 - 50 °C. A low range deviation has still no influence on the measurement and is therefore to be regarded as a warning.
Hardware Bit 2	The bit is set, if an internal hardware error were noticed and leads to the error value output (see chapter "6.3.4", page 23).
Laser diode switched off Bit 3	The bit is set, if the laser diode was switched off over the switching input. Serves only for information purposes.
Intensity warning Bit 4	The bit is set, if an intensity value of smaller 12% were determined and means that the measuring system optics, or the reflecting foil is to be cleaned. However, the device operates error-freely furthermore.
Overspeed warning Bit 5	The bit is set if the speed, adjusted in the PC program TRWinProg, is exceeded. About the default setting the speed-check is switched off.
Warning bit Plausibility Bit 6	The bit is set if the plausibility of the measured value cannot be guaranteed. E.g. this is the case at a position jump if a second reflection foil is held into the laser beam.

6.5.3 Hardware-Info

The Hardware-Info refers to bit two "Hardware Error" in the Device state and specifies the hardware error in detail.

Error-Code
Bit 0, Failure Fieldbus-Chip
Bit 1, undefined Measuring length
Bit 2, Failure Temperature-Sensor
Bit 3, Failure ext. Flash

6.6 Speed

6.6.1 Speed-Values

Adjusting of the velocity level. If the adjusted velocity level is exceeded, this is signaled with the setting of the switching output. For this, about the function of the switching output the output must be defined as "Speed-check" (see "Fail Output", page 23).

Selection	Description	Default
0	Function disabled	X
free input: 1 - 200	Speed in 0,1 m/s	

6.6.2 Dynamic

Time constant for calculating the speed.

Selection	Description	Default
Auto-Dynamic	Dynamic ranging depending from the speed level.	X
Range 1	lower delay, higher noise	
Range 2	middle delay, middle noise	
Range 3	higher delay, lower noise	

6.6.3 Output-Format

Definition of the output format for the speed which is displayed in the tab *Actual values*.

Selection	Description	Default
1 mm / sec	Output of the speed in 1 mm/s	
10 mm / sec	Output of the speed in 10 mm/s	X

6.6.4 Sign

Definition if the speed, which is displayed in the tab *Actual value*, is output with sign or without sign.

Selection	Description	Default
no sign, always positive	Output without sign	X
direction depending sign	Output as value with sign	

7 Causes of Faults and Remedies

The error causes are determined in chapter "Device state", page 27. Depending on setting the error messages must be acknowledged for resetting the error, see chapter "Failure-quit", page 23.

Error	Cause	Remedy
Bit 0 Intensity error	The device checks the intensity of the received laser signal continuously, it was detected a below-minimum intensity.	<ol style="list-style-type: none"> 1. Clean measuring system optics 2. Clean reflecting foil 3. Rule out an interruption of the laser beam <p>If the possibility of soiling or interruption of the laser signal can be ruled out, the device must be replaced.</p>
Bit 1 Device temperature	The temperature has exceeded or fallen short of the range of 0 - 50°C at the housing of the device	Appropriate measures must be taken to prevent the device from overheating or undercooling.
Bit 2 Hardware error	The device has detected an internal hardware error.	If the error occurs repeated, the device must be replaced.
Bit 3 Laser diode switched off	The bit is set, if the laser diode was switched off over the bus, or the switching input.	Serves only for information purposes.
Bit 4 Intensity warning	The device determined an intensity of < 12%.	This message is only a warning and means that the measuring system optics, or the reflecting foil is to be cleaned. However, the device operates error-free furthermore.
Bit 5 Speed-check warning	The speed level adjusted over the PC program TRWinProg was exceeded.	This message is a warning and means that possibly corresponding measures must be taken, so that no system components will be damaged.
Bit 6 Plausibility warning	The plausibility of the measured value couldn't be guaranteed any more.	This message is a warning and means that possibly corresponding measures must be taken, so that no system components will be damaged.