

Profinet Encoders



! This preliminary information is not guarantee of device characteristics or performance.
All rights to technical changes reserved.

Table of Contents

1. Performance & Interfaces	3
2. Electrical & Mechanical & Ambient Data	4
3. Dimensional Drawing	5
4. Connector & Pin Assignment	6

1. Performance & Interfaces

FNC PROFINET



Ordering Part Number Clamping Flange

Type	Resolution	Shaft Diameter	Part Number
Singleturn	18 bit	8 mm	FNC APS 58B8 S18
Singleturn	18 bit	10 mm	FNC APS 58B10 S18
Singleturn	18 bit	12 mm	FNC APS 58B12 S18
Multiturn	Singleturn 18 bit Multiturn 12 bit	8 mm	FNC APM 58B8 S18M12
Multiturn	Singleturn 18 bit Multiturn 12 bit	10 mm	FNC APM 58B10 S18M12
Multiturn	Singleturn 18 bit Multiturn 12 bit	12 mm	FNC APM 58B12 S18M12

Performance

Number of steps per revolution (max. resolution)	262.144 (18 bit)
Number of revolutions	4.096 (12 bit)
Max. resolution (number of steps per revolution x number of revolutions)	18 bit x 12 bit (262.144 x 4.096)

Interfaces

Communication interface	PROFINET
Encoder profile	V4.1 class3
Data transmission rate (baud rate)	10 Mbit/s 100 Mbit/s
Transmission medium	CAT-5e cable
Initialization time	6 s
Cycle time	≤ 1 ms

Parameterising data	<ul style="list-style-type: none"> Number of steps per revolution Number of revolutions PRESET Counting direction Sampling rate for speed calculation Unit for output of the speed value
Available diagnostics data	<ul style="list-style-type: none"> Minimum and maximum temperature Maximum speed Power-on counter Operating hours counter power-on/motion Counter of direction changes/number of movements cw/number of movements ccw Maximum supply voltage

2. Electrical & Mechanical & Ambient Data

Electrical data

Connection type	Male connector, 1x, M12, 4-pin, axial (A-coded) Female connector, 2x, M12, 4-pin, axial (D-coded)
Supply voltage	10 ... 30 V
Power consumption	≤ 3 W (without load)
Reverse polarity protection	+

Mechanical data

Mechanical design	Solid shaft, face mount flange
Shaft diameter	10 mm
Shaft length	19 mm
Weight	0.2 kg
Shaft material	Stainless steel
Flange material	Aluminum
Housing material	Aluminum
Start up torque	0.5 Ncm (+20 °C)
Operating torque	0.3 Ncm (+20 °C)
Permissible Load capacity of shaft	80 N / radial 40 N / axial
Operating speed	≤ 9,000 min ⁻¹
Moment of inertia of the rotor	6.2 gcm ²
Moment of inertia of the rotor	3 × 10 ⁹ revolutions
Moment of inertia of the rotor	≤ 500,000 rad/s ²

Ambient data

EMC	According to EN 61000-6-2 and EN 61000-6-3
Enclosure rating	IP65, shaft side (according to IEC 60529) IP67, housing side (according to IEC 60529) ¹⁾
Permissible relative humidity	90 % (condensation of the optical scanning not permitted)
Operating temperature range	-40 °C ... +85 °C
Storage temperature range	-40 °C ... +100 °C, without package
Resistance to shocks	100 g, 6 ms (according to EN 60068-2-27)
Resistance to vibration	30 g, 10 Hz ... 2,000 Hz (according to EN 60068-2-6)

1) With mating connector inserted.

3. Dimensional Drawing

Dimensional Drawing

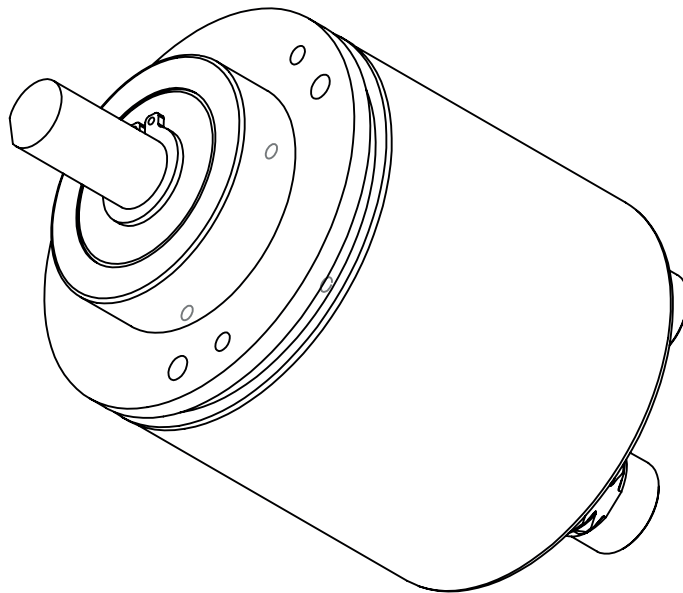
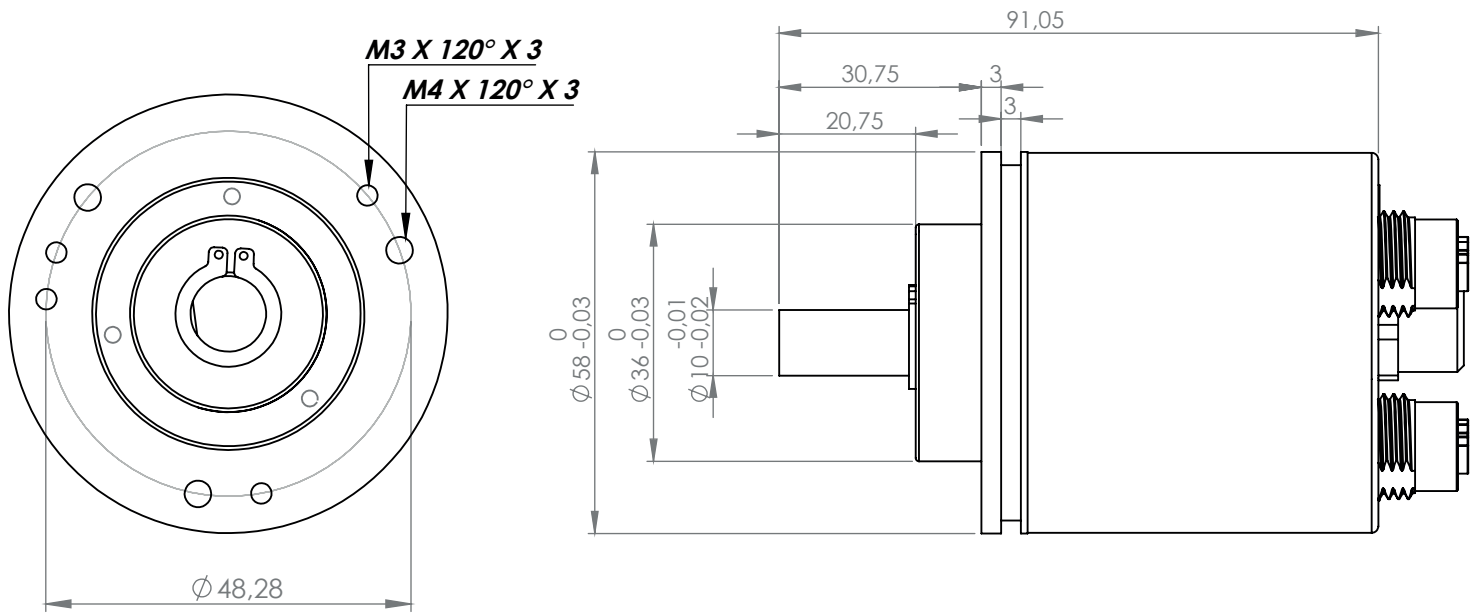

4. Connector & Pin Assignment

Pin Assignment

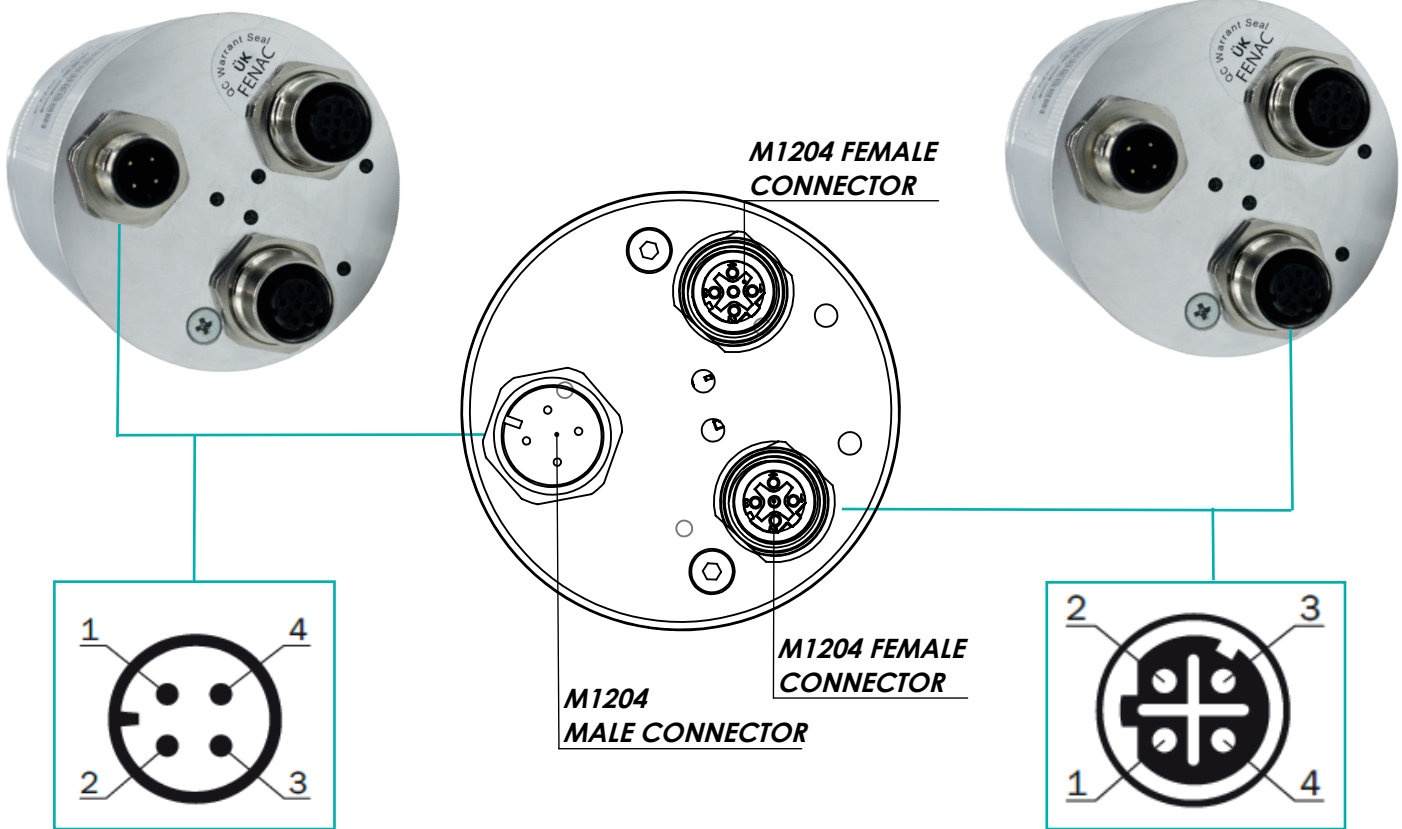

PIN	Signal
-----	--------

1	U _s 10 V...30V
---	---------------------------

2	Not assigned
---	--------------

3	GND
---	-----

4	Not assigned
---	--------------

PIN	Signal
-----	--------

1	T x D+
---	--------

2	R x D+
---	--------

3	T x D-
---	--------

4	R x D-
---	--------

Counter Connector Part Number

FCSF M1204 : M1204 Female Connector

FCSF M1204 R200 : M1204 Female Connector with 2 meter cable



Counter Connector Part Number

FCSM DTM1204 : D Type M1204 Female Connector

FCSM DTM1204 R200 : D Type M1204 Female Connector with 2 meter cable

