

EPSON

EPSON ProSix

C3 series

C3 Manipulator

Rev.4

EM105R2013F

EPSON ProSix C3 series C3 Manipulator Rev. 4

EPSON ProSix

C3 series

C3 Manipulator

Rev. 4

FOREWORD

Thank you for purchasing our robot products.

This manual contains the information necessary for the correct use of the manipulator.

Please carefully read this manual and other related manuals before installing the robot system.

Keep this manual handy for easy access at all times.

WARRANTY

The robot and its optional parts are shipped to our customers only after being subjected to the strictest quality controls, tests, and inspections to certify its compliance with our high performance standards.

Product malfunctions resulting from normal handling or operation will be repaired free of charge during the normal warranty period. (Please ask your Regional Sales Office for warranty period information.)

However, customers will be charged for repairs in the following cases (even if they occur during the warranty period):

1. Damage or malfunction caused by improper use which is not described in the manual, or careless use.
2. Malfunctions caused by customers' unauthorized disassembly.
3. Damage due to improper adjustments or unauthorized repair attempts.
4. Damage caused by natural disasters such as earthquake, flood, etc.

Warnings, Cautions, Usage:

1. If the robot or associated equipment is used outside of the usage conditions and product specifications described in the manuals, this warranty is void.
2. If you do not follow the WARNINGS and CAUTIONS in this manual, we cannot be responsible for any malfunction or accident, even if the result is injury or death.
3. We cannot foresee all possible dangers and consequences. Therefore, this manual cannot warn the user of all possible hazards.

TRADEMARKS

Microsoft, Windows, and Windows logo are either registered trademarks or trademarks of Microsoft Corporation in the United States and/or other countries. Other brand and product names are trademarks or registered trademarks of the respective holders.

NOTICE

No part of this manual may be copied or reproduced without authorization.

The contents of this manual are subject to change without notice.

Please notify us if you should find any errors in this manual or if you have any comments regarding its contents.

INQUIRIES

Contact the following service center for robot repairs, inspections or adjustments.

If service center information is not indicated below, please contact the supplier office for your region.

Please prepare the following items before you contact us.

- Your controller model and its serial number
- Your manipulator model and its serial number
- Software and its version in your robot system
- A description of the problem

SERVICE CENTER



MANUFACTURER & SUPPLIER

Japan & Others

SEIKO EPSON CORPORATION

Suwa Minami Plant

Factory Automation Systems Dept.

1010 Fujimi, Fujimi-machi,

Suwa-gun, Nagano, 399-0295

JAPAN

TEL : +81-(0)266-61-1802

FAX : +81-(0)266-61-1846

SUPPLIERS

North & South America **EPSON AMERICA, INC.**

Factory Automation/Robotics

18300 Central Avenue

Carson, CA 90746

USA

TEL : +1-562-290-5900

FAX : +1-562-290-5999

E-MAIL : info@robots.epson.com

Europe

EPSON DEUTSCHLAND GmbH

Factory Automation Division

Otto-Hahn-Str.4

D-40670 Meerbusch

Germany

TEL : +49-(0)-2159-538-1391

FAX : +49-(0)-2159-538-3170

E-MAIL : robot.infos@epson.de

For Customers in the European Union



The crossed out wheeled bin label that can be found on your product indicates that this product and incorporated batteries should not be disposed of via the normal household waste stream. To prevent possible harm to the environment or human health please separate this product and its batteries from other waste streams to ensure that it can be recycled in an environmentally sound manner. For more details on available collection facilities please contact your local government office or the retailer where you purchased this product. Use of the chemical symbols Pb, Cd or Hg indicates if these metals are used in the battery.

This information only applies to customers in the European Union, according to DIRECTIVE 2006/66/EC OF THE EUROPEAN PARLIAMENT AND OF THE COUNCIL OF 6 September 2006 on batteries and accumulators and waste batteries and accumulators and repealing Directive 91/157/EEC and legislation transposing and implementing it into the various national legal systems.

For other countries, please contact your local government to investigate the possibility of recycling your product.

The battery removal/replacement procedure is described in the following manuals:
Controller manual / Manipulator manual (Maintenance section)

Before Reading This Manual

This section describes what you should know before reading this manual.

Structure of Control System

C3 Manipulators can be used with the following combinations of Controllers and software.

The operating methods and descriptions are different depending on which software you are using. The following icons are put beside appropriate text as necessary. Use the descriptions that pertain to the software you are using.

Controller		Software
Name	Structure	
RC180	Controller	EPSON RC+ 5.0
RC620	Control Unit Drive Unit	EPSON RC+ 6.0 Ver. 6.0 or greater

For details on commands, refer to “EPSON RC+ User’s Guide” or “On-line help”.

Turning ON/OFF Controller

When you see the instruction “Turn ON/OFF the Controller” in this manual, be sure to turn ON/OFF all the hardware components.

Photos and Illustrations Used in This Manual

The appearance of some parts may differ from those on an actual product depending on when it was shipped or the specifications. The procedures themselves, however, are accurate.

TABLE OF CONTENTS

Before Reading This Manual	v
----------------------------------	---

Setup & Operation

1. Safety	3
1.1 Conventions	3
1.2 Design and Installation Safety	3
1.3 Operation Safety	4
1.4 Emergency Stop	5
1.5 How to Move Arms the Electromagnetic Brake is Applied to	6
1.5.1 Moving the Arm Using the Brake Release Unit	7
1.5.2 Moving the Arm Using the Software	7
1.6 Precaution for Operation in Low Power Status	8
1.7 Manipulator Labels	9
2. Specifications	11
2.1 Features of Manipulators	11
2.2 Model Number	11
2.3 Part Names and Motion Range of Each Arm	12
2.4 Outer dimensions	13
2.5 Standard Motion Range	14
2.6 Specifications	15
2.6.1 Specifications table	15
2.6.2 Option	17
2.7 How to Set the Model	17
3. Environment and Installation	18
3.1 Environmental Conditions	18
3.2 Unpacking, Transportation, and Relocation	19
3.3 Mounting Dimensions	21
3.4 Installation	22
3.5 Connecting the Cables	24
3.6 User Wires and Pneumatic Tubes	25
3.7 Checking the Basic orientation	27
4. End Effectors	28
4.1 Attaching an End Effector	28
4.2 Attaching Camera and Valves	29
4.3 WEIGHT and INERTIA Settings	30
4.3.1 WEIGHT Setting	32
4.3.2 INERTIA Setting	37
4.4 Precautions for Auto Acceleration/Deceleration	41

5. Motion Range	42
5.1 Motion Range Setting by Pulse Range (for All Arms)	42
5.1.1 Max. Pulse Range of Arm #1	43
5.1.2 Max. Pulse Range of Arm #2	43
5.1.3 Max. Pulse Range of Arm #3	44
5.1.4 Max. Pulse Range of Arm #4	44
5.1.5 Max. Pulse Range of Arm #5	45
5.1.6 Max. Pulse Range of Arm #6	45
5.2 Motion Range Setting by Mechanical Stops	45
5.2.1 Motion Range Setting of Arm #1	46
5.2.2 Motion Range Setting of Arm #2 and #3 (Option)	46
5.2.3 Motion Range Setting of Arm #3	46
5.3 Restriction of Manipulator Operation by Joint Angle Combination of Arm #1, #2, and #3	47
5.4 Coordinate System	48
5.5 Setting the Cartesian (Rectangular) Range in the XY Coordinate System of the Manipulator	48
6. Options	49
6.1 Brake Release Unit	49
6.2 Camera Plate Unit	54
6.3 PS Compatible Plate	57
6.4 Base Side Angled Fittings	58
6.5 Base Side Fittings	61

Maintenance

1. Safety Maintenance	67
2. General Maintenance	68
2.1 Schedule for Maintenance Inspection	67
2.2 Inspection Point	69
2.3 Greasing	70
2.4 Tightening Hexagon Socket Head Cap Bolts	71
2.5 Layout of Maintenance Parts	72
3. Covers	73
3.1 Arm #1 Top Cover	74
3.2 Arm #1 Side Cover	74
3.3 Arm #2 Side Cover	75
3.4 Arm #3 Head Cover	76
3.5 Arm #3 Bottom Cover	76
3.6 Arm #4 Side Cover	77
3.7 Base Bottom Cover	78
3.8 Connector Plate	78
3.9 Connector Sub Plate	79
3.10 User Plate	79

4. Cable Unit	80
4.1 Replacing the Cable Unit	80
4.2 Connector Pin Assignments	91
4.2.1 Signal Cable	91
4.2.2 Power Cable	93
4.2.3 User Cable	95
4.2.4 Color of Cables	95
5. Arm #1	96
5.1 Motor	97
5.2 Reduction Gear Unit	103
5.3 Timing Belt	106
5.4 Electromagnetic Brake	107
6. Arm #2	108
6.1 Motor	110
6.2 Reduction Gear Unit	115
6.3 Timing Belt	120
6.4 Electromagnetic Brake	121
7. Arm #3	122
7.1 Motor	123
7.2 Reduction Gear Unit	127
7.3 Timing Belt	131
7.4 Electromagnetic Brake	132
8. Arm #4	133
8.1 Motor	134
8.2 Reduction Gear Unit	140
8.3 Timing Belt	145
8.4 Electromagnetic Brake	146
9. Arm #5	147
9.1 Motor	148
9.2 Timing Belt	152
9.3 Electromagnetic Brake	153
10. Arm #6	154
10.1 Motor	155
10.2 Timing Belt	161
10.3 Electromagnetic Brake	162
11. Joint #5 and #6 Unit	163
12. Arm #5 O-Ring	168

13. Battery Unit	169
13.1 Battery Unit (Lithium Bttery)	170
13.2 Battery Board	172
14. LED Lamp	173
15. M/C Cable	175
16. Calibration	177
17. Maintenance Parts List	179

Setup & Operation

This volume contains information for setup and operation of the Manipulators.

Please read this volume thoroughly before setting up and operating the Manipulators.

1. Safety



Installation and transportation of robots and robotic equipment shall be performed by qualified personnel and should conform to all national and local codes.

Please read this manual and other related manuals before installing the robot system or before connecting cables.

Keep this manual handy for easy access at all times.

1.1 Conventions

Important safety considerations are indicated throughout the manual by the following symbols. Be sure to read the descriptions shown with each symbol.

 WARNING	This symbol indicates that a danger of possible serious injury or death exists if the associated instructions are not followed properly.
 WARNING	This symbol indicates that a danger of possible harm to people caused by electric shock exists if the associated instructions are not followed properly.
 CAUTION	This symbol indicates that a danger of possible harm to people or physical damage to equipment and facilities exists if the associated instructions are not followed properly.

1.2 Design and Installation Safety

Only trained personnel should design and install the robot system. Trained personnel are defined as those who have taken robot system training and maintenance training classes held by the manufacturer, dealer, or local representative company, or those who understand the manuals thoroughly and have the same knowledge and skill level as those who have completed the training courses.

To ensure safety, a safeguard must be installed for the robot system. For details on the safeguard, refer to the *Installation and Design Precautions* in the *Safety* chapter of the EPSON RC+ User's Guide.

The following items are safety precautions for design personnel:

 WARNING	<ul style="list-style-type: none"> ■ Personnel who design and/or construct the robot system with this product must read the <i>Safety</i> chapter in the EPSON RC+ User's Guide. Designing and/or constructing the robot system without understanding the safety requirements is extremely hazardous, and may result in serious bodily injury and/or severe equipment damage to the robot system.
--	--

 WARNING	<ul style="list-style-type: none"> ■ The Manipulator and the Controller must be used within the environmental conditions described in their respective manuals. This product has been designed and manufactured strictly for use in a normal indoor environment. Using the product in an environment that exceeds the specified environmental conditions may not only shorten the life cycle of the product but may also cause serious safety problems. ■ The robot system must be used within the installation requirements described in the manuals. Using the robot system outside of the installation requirements may not only shorten the life cycle of the product but also cause serious safety problems.
--	---

Further precautions for installation are mentioned in the chapter *Setup & Operation 3. Environment and Installation*. Please read this chapter carefully to understand safe installation procedures before installing the robots and robotic equipment.

1.3 Operation Safety

The following items are safety precautions for qualified Operator personnel:

 WARNING	<ul style="list-style-type: none"> ■ Please carefully read the <i>Safety-related Requirements</i> in the <i>Safety</i> chapter of the EPSON RC+ User's Guide. Operating the robot system without understanding the safety requirements is extremely hazardous and may result in serious bodily injury and/or severe equipment damage to the robot system. ■ Do not enter the operating area of the Manipulator while the power to the robot system is turned ON. Entering the operating area with the power ON is extremely hazardous and may cause serious safety problems as the Manipulator may move even if it seems to be stopped. ■ Before operating the robot system, make sure that no one is inside the safeguarded area. The robot system can be operated in the mode for teaching even when someone is inside the safeguarded area. The motion of the Manipulator is always in restricted status (low speeds and low power) to secure the safety of an operator. However, operating the robot system while someone is inside the safeguarded area is extremely hazardous and may result in serious safety problems in case that the Manipulator moves unexpectedly. ■ Immediately press the Emergency Stop switch whenever the Manipulator moves abnormally while the robot system is operated. Continuing the operating the robot system while the Manipulator moves abnormally is extremely hazardous and may result in serious bodily injury and/or severe equipment change to the robot system.
--	--



- Be sure to connect the AC power cable to a power receptacle. DO NOT connect it directly to a factory power source. To shut off power to the robot system, pull out the power plug from the power source. Performing any work while connecting the AC power cable to a factory power source is extremely hazardous and may result in electric shock and/or malfunction of the robot system.
- Before performing any replacement procedure, turn OFF the Controller and related equipment, and then pull out the power plug from the power source. Performing any replacement procedure with the power ON is extremely hazardous and may result in electric shock and/or malfunction of the robot system.
- Do not insert or pull out the motor connectors while the power to the robot system is turned ON. Inserting or pulling out the motor connectors with the power ON is extremely hazardous and may result in serious bodily injury as the Manipulator may move abnormally, and also may result in electric shock and/or malfunction of the robot system.

1.4 Emergency Stop

If the Manipulator moves abnormally during operation, immediately press the Emergency Stop switch. The motor power will be turned OFF, and the arm motion by inertia will be stopped with the electromagnetic brake and dynamic brake.

However, avoid pressing the Emergency Stop switch unnecessarily while the Manipulator is running normally. Otherwise, the Manipulator may hit the peripheral equipment since the operating trajectory while the robot system stops is different from that in normal operation.

To place the robot system in emergency mode during normal operation, press the Emergency Stop switch when the Manipulator is not moving.

Refer to the Controller manual for instructions on how to wire the Emergency Stop switch circuit.

Free running distance in emergency

The operating Manipulator cannot stop immediately after the Emergency Stop switch is pressed.

However, remember that the values vary depending on conditions such as the weight of the end effector and work piece, WEIGHT/SPEED/ACCEL settings, operating pose, etc.

The free running time/angle/distance of the Manipulator are shown below.

Conditions of Measurement

ACCEL Setting	100
SPEED Setting	100
Load [kg]	3
WEIGHT Setting	3

Robot controller		RC180 / RC620	
Brake		Standard J2, J3, J5 with brake	Option All joint with brake
Free running time [sec.]	Arm #1	0.4	
	Arm #2	0.4	
	Arm #3	0.4	
	Arm #4	0.5	0.3
	Arm #5	0.3	
	Arm #6	0.1	
Free running angle [deg.]	Arm #1	85	
	Arm #2	60	
	Arm #3	55	
	Arm #4	55	45
	Arm #5	45	
	Arm #6	10	

1.5 How to Move Arms the Electromagnetic Brake is Applied to

Standard: Brakes on Joints #2, #3, #5

While the electromagnetic brake is ON (such as in emergency mode), you can move Arms #1, #4, #6 by pushing manually.

Option : Brakes on all joints

While the electromagnetic brake is ON (such as in emergency mode), you cannot move any arm by pushing manually.

There are two methods to release the electromagnetic brake. Follow either method to release the electromagnetic brake and move the arms manually.

1.5.1 Moving the arm using the brake release unit

Follow the method when you just unpack the delivered boxes or when the Controller does not start up yet.

1.5.2 Moving the arm using the software

Follow the method when you can use the software.

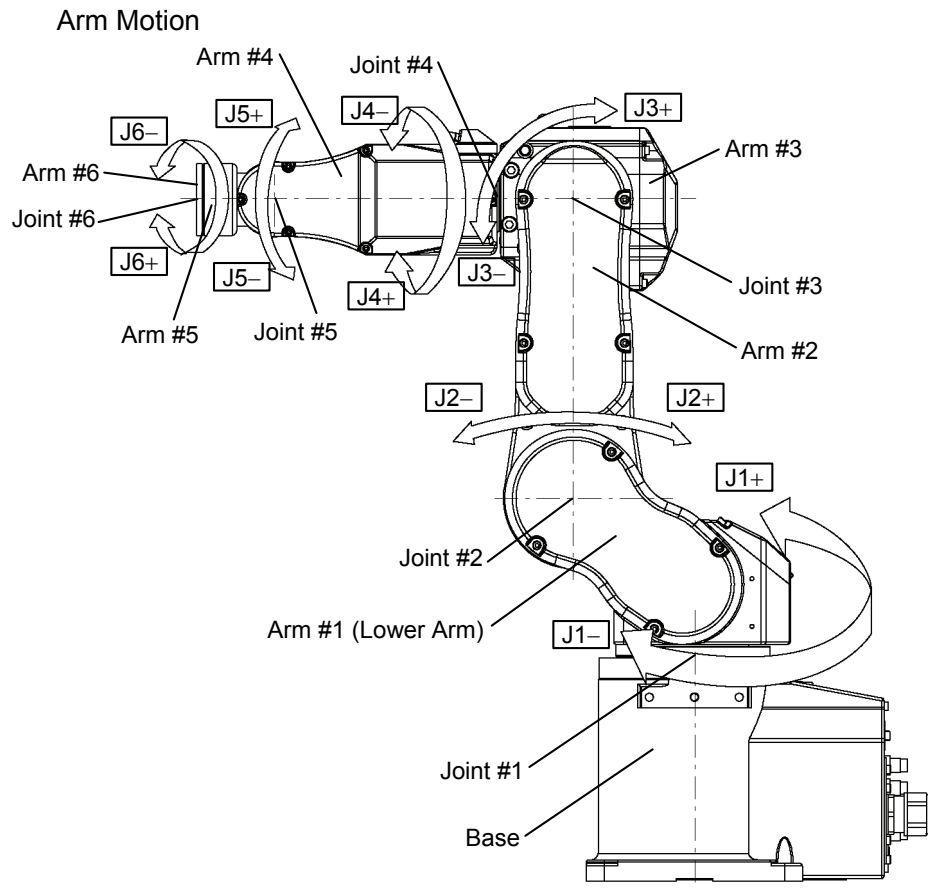

1.5.1 Moving the arm using the brake release unit

The C3 series has the Brake Release Unit as an option.
For details, refer to *Setup & Option: 6 Options*.

1.5.2 Moving the arm using the software



CAUTION

- Normally, release the brake of a single joint at a time. Take extra care to release the brakes of two or more joints simultaneously from necessity. Releasing the brakes of two or more joints simultaneously may cause hands and fingers to be caught and/or equipment damage to or malfunction of the Manipulator as the arms of the Manipulator may move in unexpected directions.
- Be careful of the arm falling when releasing the brake. While the brake is being released, the Manipulator's arm falls by its own weight. The arm falling may cause hands and fingers to be caught and/or may cause equipment damage to or malfunction of the Manipulator.
- Before releasing the brake, be sure to keep the Emergency Stop switch handy so that you can immediately press the Emergency Stop switch. If you cannot immediately press the Emergency Stop switch, you have no means to stop the arms urgently when a wrong operation causes the arm to fall. The arm falling may cause equipment damage to and/or malfunction of the Manipulator.

EPSON
RC+

After releasing the Emergency Stop switch, Execute the following commands.

[Command Window] EPSON RC+ 5.0 (RC180) / EPSON RC+ 6.0 (RC620)

>Reset

>Brake Off, [the number (from 1 to 6) corresponding to the arm whose brake will be turned off]

Execute the following command to turn on the brake again.

>Brake On, [The number (from 1 to 6) corresponding to the arm whose brake will be turned on]

1.6 Precaution for Operation in Low Power Status

When the power mode is low, the Manipulator will operate at low speed and low torque. However, comparatively high torque is generated under some circumstances so that the Manipulator can support its own weight. The maximum torque of each joint in the low power status is shown in the following table “Max. Joint Torque in Low Power Status”.

Even though the Manipulator is in the low power status, carefully operate the Manipulator since a comparatively high joint torque may be generated. Be careful not to get hands or fingers caught during operations. The Manipulator may also collide with peripheral equipment and it may cause equipment damage to or malfunction of the Manipulator.

Max. Joint Torque in Low Power Status

[Unit: N·m]

Joint	#1	#2	#3	#4	#5	#6
Joint Torque	102.28	102.28	33.51	10.31	10.31	7.98



CAUTION



- Carefully operate the Manipulator even though it is in the low power status. A comparatively high joint torque may be generated. The comparatively high joint torque may cause hands and fingers to be caught and/or may cause equipment damage to or malfunction of the Manipulator as it may collide with peripheral equipment.

1.7 Manipulator Labels

The following labels are attached around the locations of the Manipulator where specific dangers exist.

Be sure to comply with descriptions and warnings on the labels to operate and maintain the Manipulator safely.

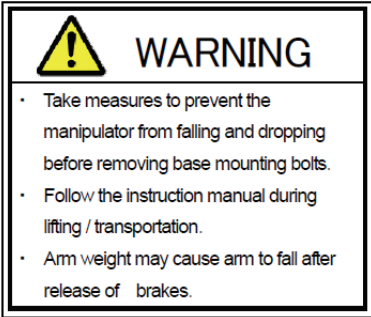
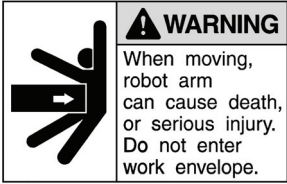
Do not tear, damage, or remove the labels. Use meticulous care when handling those parts or units to which the following labels are attached as well as the nearby areas:

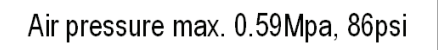
Location	Label	NOTE
(1)		Hazardous voltage exists while the Manipulator is ON. To avoid electric shock, do not touch any internal electric parts.
(2)		Only authorized personnel should perform sling work and operate a crane and a forklift. When these operations are performed by unauthorized personnel, it is extremely hazardous and may result in serious bodily injury and/or severe equipment damage to the robot system.
(3)		
(4)		
(5)		

Location	Label	NOTE
(6)	<div style="border: 1px solid black; padding: 5px;"> <p>MODEL : <u>C3-A600SR</u> SERIAL NO. : <u>0 0 0 0 1</u> MANUFACTURED : <u>0 7 / 2 0 0 9</u> WEIGHT : <u>27kg</u> MAX PAYLOAD : <u>3kg</u> MOTOR POWER AXIS1 : 400W AXIS2 : 400W AXIS3 : 150W AXIS4 : 50W AXIS3 : 50W AXIS4 : 50W SEIKO EPSON CORPORATION 3-5,OWA 3-CHOME,SUWA-SHI NAGANO-KEN,392-8502 JAPAN</p> </div>	
(7)	<div style="border: 1px solid black; padding: 5px;">  <p>WARNING Arm weight may cause arm to fall after release of brake.</p> </div>	<p>Be careful of the arm falling / rotation while the brake release button is being pressed. * This label is on the Brake Release Box (Option).</p>

Location of Labels

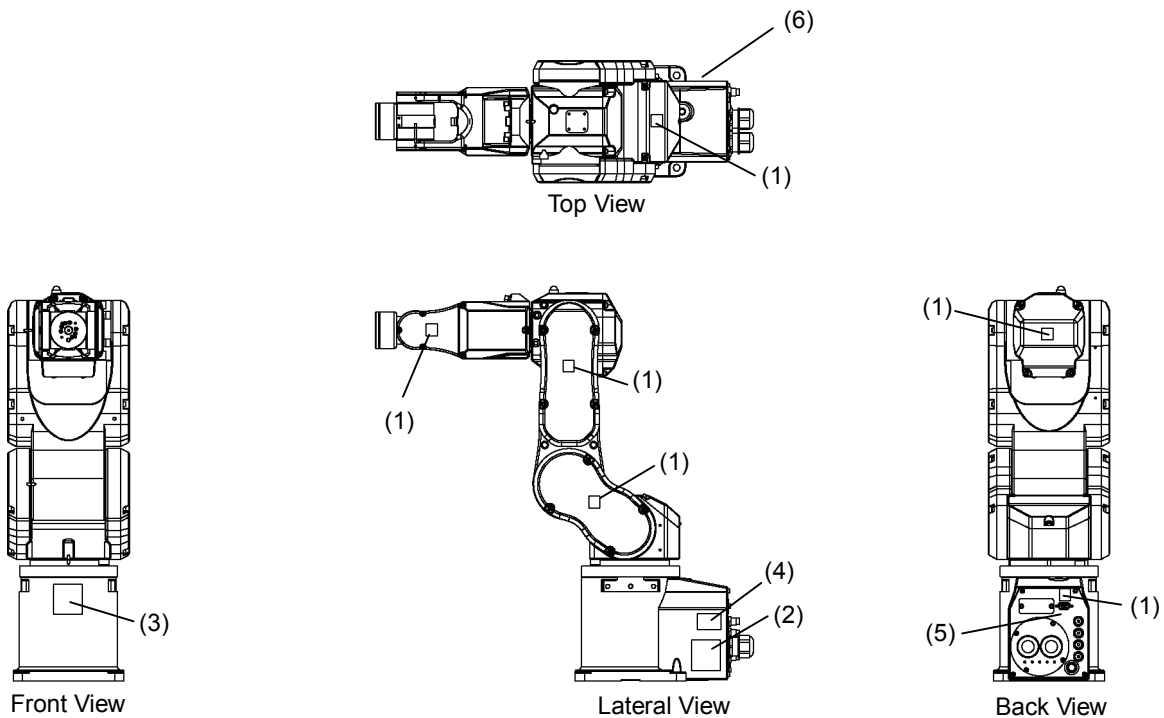

2. Specifications

2.1 Features of Manipulators

Speed & Accuracy

Increases productivity with the balanced performance of best in class speed and accuracy

Average cycle time (300 mm) 0.39 second (Speed 100 / Accel 100)
 0.37 second (Speed 120 / Accel 120)

Repeatability ± 0.02 mm

Slim Body

High space efficiency

Manipulator volume only 1/44 of its motion range

Small elbow area (Joint #3) half of current model

Less interference with peripherals, walls and ceiling permits more compact installation

Skillful Wrist

Compact wrist (Joint #5) with wide motion range enables smooth movement and the ability to work from many angles

Minimal interference with surroundings improves flexibility in hand design

2.2 Model Number

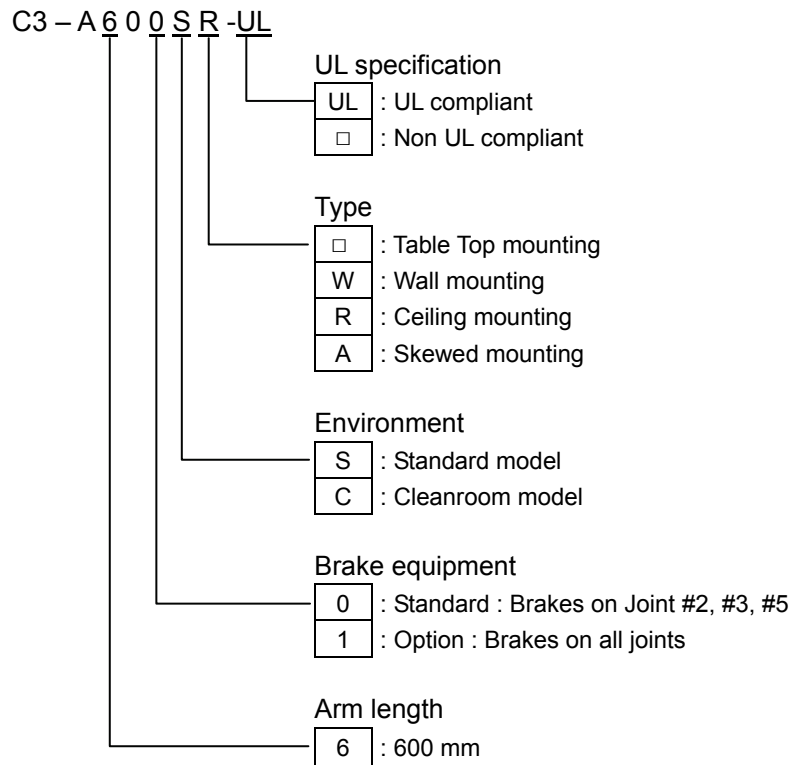

For the Wall / Skewed mounting types, brakes are equipped on all joints.

2.3 Part Names and Motion Range of Each Arm

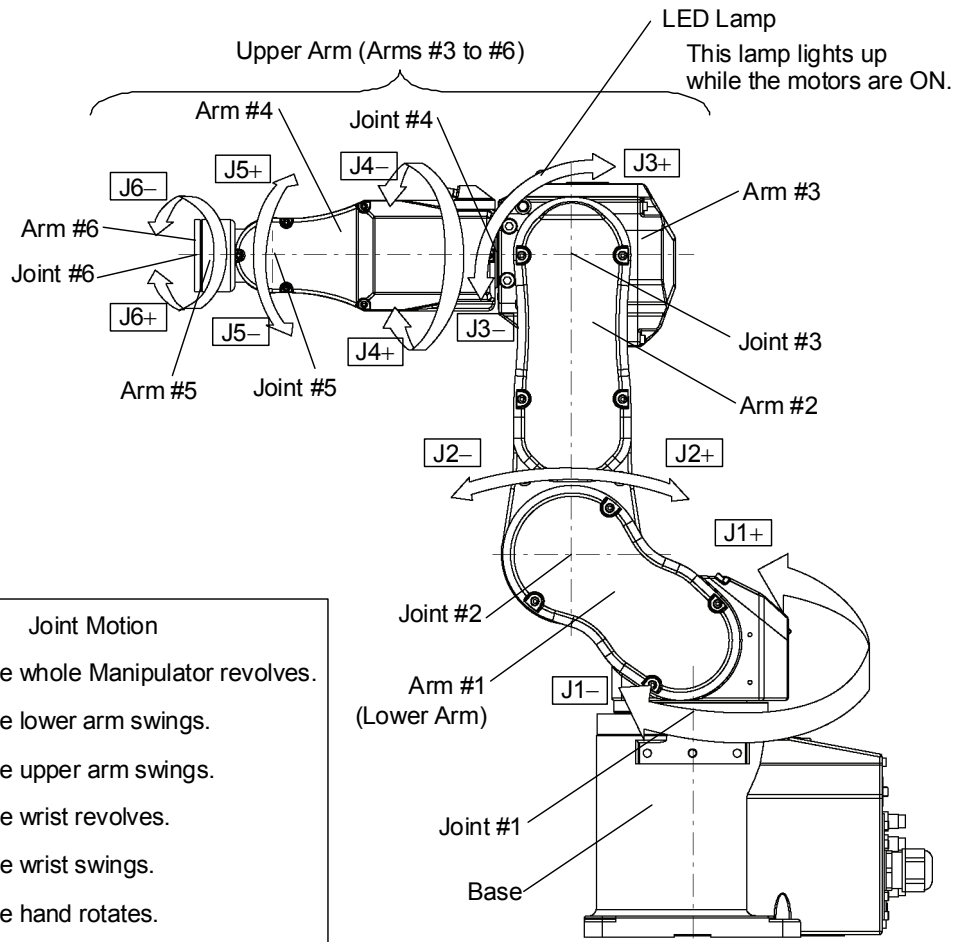

Joint Motion
 Joint #1 : The whole Manipulator revolves.
 Joint #2 : The lower arm swings.
 Joint #3 : The upper arm swings.
 Joint #4 : The wrist revolves.
 Joint #5 : The wrist swings.
 Joint #6 : The hand rotates.

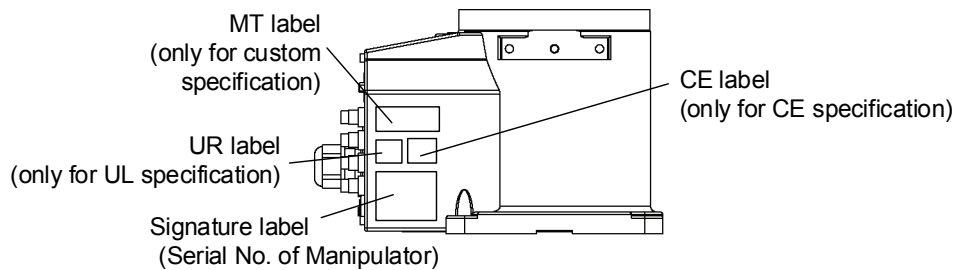
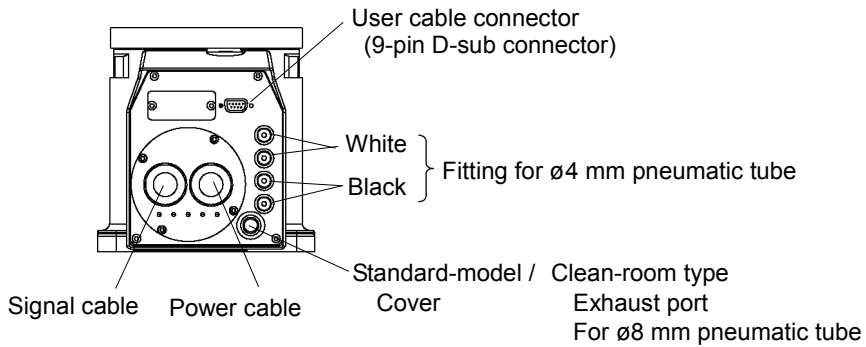

NOTE

When the LED lamp is lighting or the controller power is on, the current is being applied to the manipulator. Performing any work with the power ON is extremely hazardous and it may result in electric shock and/or improper function of the robot system. Make sure to turn OFF the controller power before the maintenance work.

2.4 Outer Dimensions

[Unit: mm]

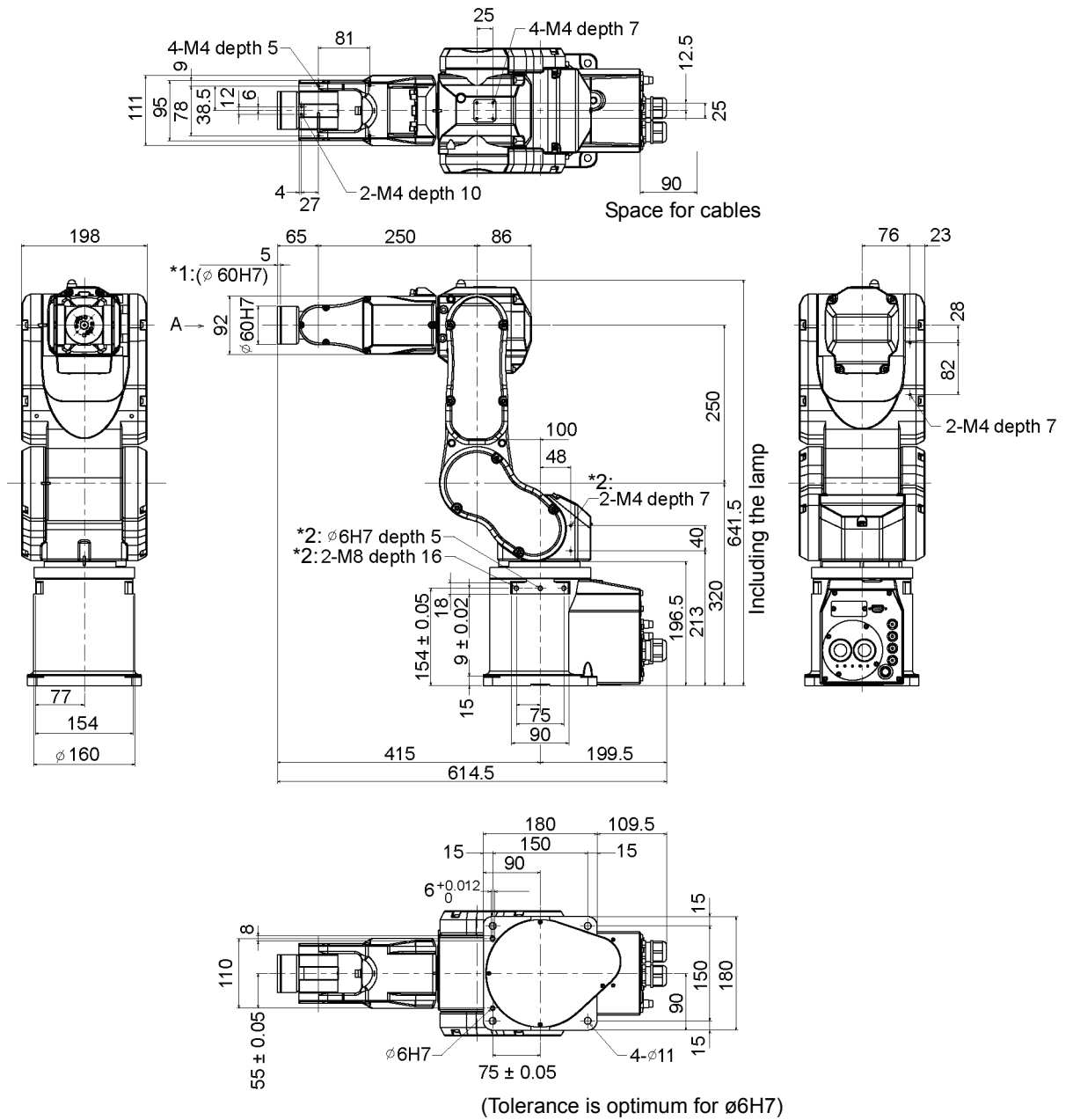

*1: Tolerance in this range

*2: Front and back

2.5 Standard Motion Range

[Unit: mm]

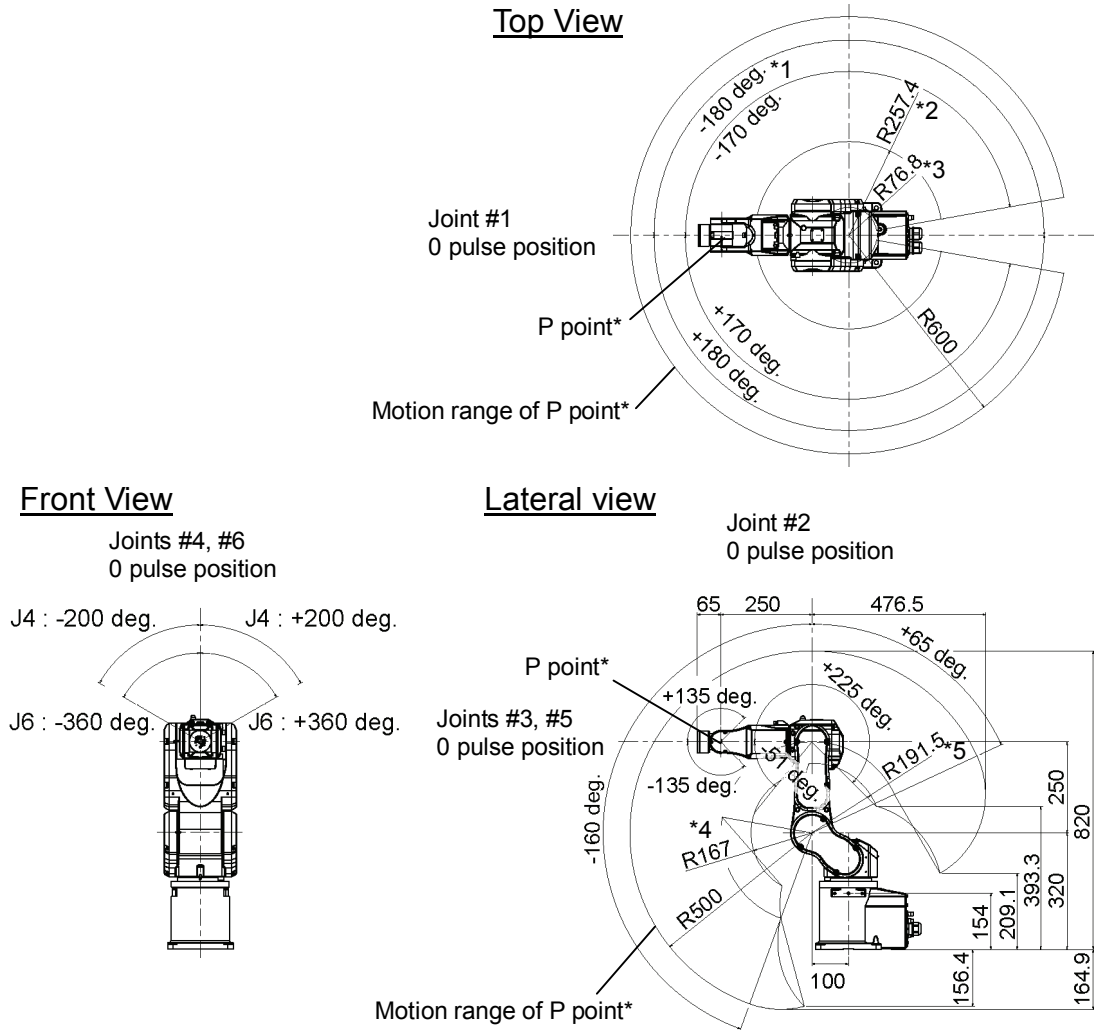

- * P point : Intersection of the rotation centers for Joint #4, #5, and #6
- *1 : Joint #1 without mechanical stop (± 180 deg.)
- *2 : P point from top with Joint #3 declining -51 deg. (Joint #1 center – P point center)
- *3 : P point from top with Joint #3 tilting up $+225$ deg. (Joint #1 center – P point center)
- *4 : P point from lateral with Joint #3 declining (51 deg. (Joint #2 center – P point center)
- *5 : P point from lateral with Joint #3 tilting up (225 deg. (Joint #2 center – P point center)

 CAUTION	<p>Pay attention to the arm pose of the basic arms (Arms #1, #2, and #3) when operating the Manipulator. Arm #5 moves keeping a constant angle regardless of the arm pose. Depending on the arm pose of the basic arms, the wrist may collide with the Manipulator. The collision may cause equipment damage to and/or malfunction of the Manipulator.</p>
---	--

2.6 Specifications

2.6.1 Specifications table

Item		Specification	
Model Number		C3	
Mounting type		Table Top, Ceiling, Skewed mounting	Wall mounting
Weight (not include the weight of cables or shipping jigs)		27 kg (59.5 lb.)	
Driving method	All joints	AC servo motor	
Max. operating speed ^{*1}	Joint #1	450 deg/s	
	Joint #2	450 deg/s	
	Joint #3	514 deg/s	
	Joint #4	553 deg/s	
	Joint #5	553 deg/s	
	Joint #6	720 deg/s	
Repeatability	Joint #1 ~ #6	± 0.02 mm	
Max. motion range	Joint #1	± 170 deg (± 180 deg without the mechanical stop)	± 30 deg
	Joint #2	- 160 deg ~ + 65 deg	
	Joint #3	- 51 deg ~ + 225 deg	
	Joint #4	± 200 deg	
	Joint #5	± 135 deg	
	Joint #6	± 360 deg	
Max. pulse range	Joint #1	± 4951609 (± 5242880 without the mechanical stop)	± 873814
	Joint #2	- 4660338 + 1893263	
	Joint #3	- 1299798 + 5734400	
	Joint #4	± 4700057	
	Joint #5	± 3217222	
	Joint #6	± 6553600	
Resolution	Joint #1	0.00000429 deg /pulse	
	Joint #2	0.00000429 deg /pulse	
	Joint #3	0.00000490 deg /pulse	
	Joint #4	0.00000531 deg /pulse	
	Joint #5	0.00000524 deg /pulse	
	Joint #6	0.00000686 deg /pulse	
Motor power consumption	Joint #1	400 W	
	Joint #2	400 W	
	Joint #3	150 W	
	Joint #4	50 W	
	Joint #5	50 W	
	Joint #6	50 W	
Payload ^{*2}	Rated	1 kg	
	Max.	3 kg 5 kg with arm downward positioning	
Allowable moment	Joint #4	4.41 N·m (0.45 kgf·m)	
	Joint #5	4.41 N·m (0.45 kgf·m)	
	Joint #6	2.94 N·m (0.3 kgf·m)	

Item		Specification
Allowable moment of inertia ($GD^2/4$) ^{*3}	Joint #4	0.15 kg·m ²
	Joint #5	0.15 kg·m ²
	Joint #6	0.1 kg·m ²
Installed wire for customer use		9 wires (D-sub)
Installed pneumatic tube for customer use ^{*4}		4 pneumatic tubes, Allowable pressure: 0.59Mpa (6 kgf/cm ²) (89 psi)
Environmental requirements ^{*5}	Ambient Temperature	5 ~ 40 deg C
	Ambient relative humidity	20 ~ 80 % (no condensation)
	Vibration	4.9 m·s ⁻² (0.5 G) or less
Equivalent continuous A-weighted sound pressure level ^{*6}		L _{Aeq} = 76 dB (A) or under
Environment		Standard model Cleanroom model ^{*7} & ESD
Applicable Controller		RC180, RC620
Default values (Max. setting values)	SPEED	5 (100)
	ACCEL	5, 5 (120, 120)
	SPEEDS	50 (2000)
	ACCELS	200 (25000)
	FINE	10000, 10000, 10000, 10000, 10000, 10000 (65535, 65535, 65535, 65535, 65535, 65535)
	WEIGHT	1, 0
Safety standard		UL1740 (Third Edition, Dated December 7,2007) ANSI/RIA R15.06-1999 NFPA 79 (2007 Edition) CSA/CAN Z434-03 (February 2003) CE Marking – Machinery Directive, Low Voltage Directive, EMC Directive

- *1 In the case of PTP control
- *2 When the setting payload is more than 3 kg and less than or equal to 5 kg, refer to the section “Restrictions on payload exceeding 3 kg (more than 3 kg and less than or equal to 5 kg)” in the *Setup & Operation 4.3.1 WEIGHT Setting*.
- *3 In the case where the center of gravity is at the center of each arm. If the center of gravity is not at the center of each arm, set the eccentric quantity using INERTIA mmand.
- *4 For details of the installed pneumatic tube for customer use, refer to the *Setup & Operation 3.6 User Wires and Pneumatic Tubes*.
- *5 For details of the environmental requirements, refer to the *Setup & Operation 3.1 Environmental Conditions*.
- *6 Conditions of Manipulator at measurement are as follows:
 Operating conditions: Under rated load, 6 arms simultaneous motion, maximum speed, maximum acceleration, and duty 50%.
 Measurement point: 1000 mm apart from the rear of Manipulator

*7: The exhaust system in the Cleanroom-model Manipulator draws air from the base interior and arm cover interior.

A crack or other opening in the base unit can cause loss of negative air pressure in the outer part of the arm, which can cause increased dust emission.

Do not remove the covers.

Seal the exhaust port and the exhaust tube with vinyl tape so that the joint is airtight.

If the exhaust flow is not sufficient, dust particle emission may exceed the specified maximum level.

Cleanliness level : Class ISO 3 (ISO14644-1)

In previous criteria; Clean Class: 10 or its equivalent

Amount of Dust (0.1 μm diameter or larger) in
28317 cm^3 (1cft) sample-air around the center
of the motion rang: 10 particles or less.)

Exhaust System : Fitting for $\varnothing 8$ mm pneumatic tube

Refer to *Setup & Operation: 3.6 User Wires and Pneumatic Tubes*.
60 L/min vacuum

Exhaust tube : Polyurethane tube

Outer diameter: $\varnothing 8$ mm (Inner diameter: $\varnothing 5$ to 6 mm)

2.6.2 Option

C3 series has the options below. For details of options, refer to *Setup & Operation: 6. Options*.

Brake release unit

Camera plate unit

PS compatible plate

Base side angled fittings

Base side fittings

2.7 How to Set the Model

The Manipulator model for your system has been set before the shipment from the factory. It is normally not required to change the model when you receive your system.



CAUTION

- When you need to change the setting of the Manipulator model, be sure to set the Manipulator model properly. Improper setting of the Manipulator model may result in abnormal or no operation of the Manipulator and/or cause safety problems.



NOTE

If an MT label is attached to the side of a Manipulator, the Manipulator has custom specifications. If the Manipulator has custom specifications, the methods for setting the model may differ from those described below. Please contact us with the number on the MT label.

The method for setting the Manipulator model depends on the software used. Refer to the chapter *Robot Configuration* in the EPSON RC+ User's Guide.

3. Environment and Installation

Installation and transportation of robots and robotic equipment shall be performed by qualified personnel and should conform to all national and local codes.

3.1 Environmental Conditions

A suitable environment is necessary for the robot system to function properly and safely. Be sure to install the robot system in an environment that meets the following conditions:

Item	Conditions
Ambient temperature*	5 deg C ~ 40 deg C
Ambient relative humidity	20 % ~ 80 % (no condensation)
First transient burst noise	2 kV or less (Power supply wire) 1 kV or less (Signal wire)
Electrostatic noise	4 kV or less
Environment	<ul style="list-style-type: none"> · Install indoors. · Keep away from direct sunlight. · Keep away from dust, oily smoke, salinity, metal powder or other contaminants. · Keep away from flammable or corrosive solvents and gases. · Keep away from water. · Keep away from shock or vibration. · Keep away from sources of electric noise.

* The ambient temperature conditions are for the Manipulators only. For the Controller the Manipulators are connected to, refer to the Controller manual.



When using the Manipulators in inadequate environments that do not meet the above conditions, please consult your distributor.

Be sure to transport and store the robot system in environments that meet the following conditions:

Item	Conditions
Ambient temperature	0 ~ 45 deg C
Ambient relative humidity	20 ~ 80 %

3.2 Unpacking, Transportation, and Relocation

Using a cart or similar equipment, transport the Manipulator in the same conditions as it was delivered. Observe the following when unpacking the Manipulator.

THE INSTALLATION SHALL BE MADE BY QUALIFIED INSTALLATION PERSONNEL AND SHOULD CONFORM TO ALL NATIONAL AND LOCAL CODES.

 WARNING	<ul style="list-style-type: none"> ■ Only authorized personnel should perform sling work and operate a crane or forklift. When these operations are performed by unauthorized personnel, it is extremely hazardous and may result in serious bodily injury and/or severe equipment damage to the robot system. ■ Stabilize the Manipulator with your hands when hoisting it. Unstable hoisting is extremely hazardous and may result in serious bodily injury and/or severe equipment damage to the robot system as the fall of the Manipulator.
---	--

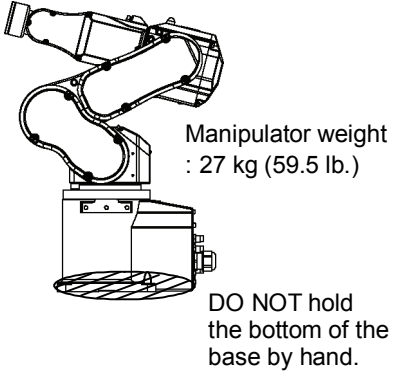
 CAUTION	<ul style="list-style-type: none"> ■ When removing the anchor bolts, support the Manipulator to prevent falling. Removing the anchor bolts without supporting the Manipulator may get hands, fingers, or feet caught as the Manipulator will fall. ■ To carry the Manipulator, have at least 2 people to work on it and secure the Manipulator to the delivery equipment or hold it by hand. Do not hold the bottom of the base (the screened parts in the figure). Holding these parts by hand is extremely hazardous and may cause your hands and fingers to be caught. ■ Avoid excessive vibration or shock during Manipulator transporting. Excessive vibration or shock may cause equipment damage to and/or malfunction of the Manipulator. 	
---	---	--

During unpacking and relocation avoid applying external force to the arms and motors of the Manipulator.

When transporting the Manipulator for a long distance, secure it to the delivery equipment so that the Manipulator cannot fall. If necessary, pack the Manipulator in the same way as it was delivered.

When condensation occurs on the Manipulator during transport or storage, turn ON the power only after the condensation dries.

When using the Manipulator for the robot system again after long-term storage, perform a test run to verify that the Manipulator works properly. Then, operate the Manipulator thoroughly.

Relocating

Follow the procedures described below when relocating the Manipulator.

- (1) Turn OFF the power for all devices and unplug the power cable connector and signal cable connector from the controller.
Do not unplug the M/C cable (power cable and signal cable) from the manipulator.



Remove the mechanical stops if using them to limit the motion range.
For details on the motion range, refer to the Setup & Operation 5.2 Motion Range Setting by Mechanical Stops.

- (2) Unscrew the anchor bolts. Then, remove the Manipulator from the base table.
- (3) Position the Manipulator as shown in the figure. Then, secure the Manipulator to the delivery equipment or have 2 or more people to carry the Manipulator.

Recommend : Joint #2 +65 deg.
Joint #3 -51 deg.

Do not hold the bottom of the base (the screened parts in the figure). Holding these parts by hand is extremely hazardous and may cause your hands and fingers to be caught.

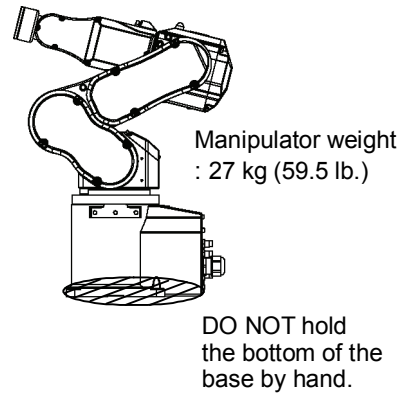

Using Eyebolt

Check that the eyebolts are securely fastened before carrying the Manipulator.
After transporting the Manipulator, remove the eyebolts and keep them for future use.
The weight of the Manipulator is approx. 27 kg (59.5 lb). The eyebolts and wire must be strong enough to withstand the weight.

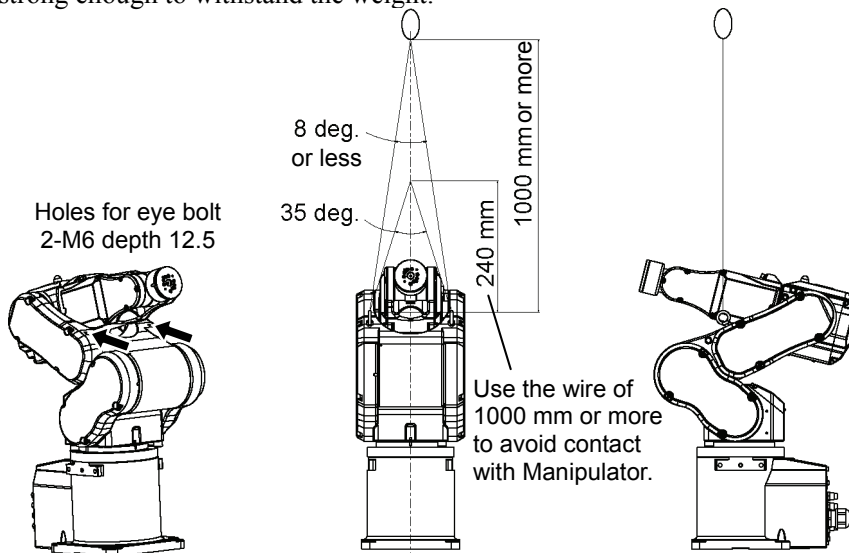

If you use the eyebolts to lift up the Manipulator, be sure to use the bifilar wire of 1000 mm-long or more to avoid contact with the Arm #4 side cover.
However, the Manipulator can swing while lifting up even with the appropriate length of wire, so be sure to handle it with care.
Take extra care if you use the wire of 240 mm-long or more to lift the Manipulator, because the wire is likely to touch the Arm #4 side cover and break the Manipulator.

3.3 Mounting Dimensions

Mounting Area

Be sure to have the following space available in addition to the space for mounting the Manipulator, Controller, and peripheral equipment.

- Space for teaching points
- Space for maintenance and inspections
- Space for cables



The minimum bend radius of the power cable is 90 mm. When installing the cable, be sure to maintain sufficient distance from obstacles. In addition, leave enough space for other cables so that they are not bent forcibly.

Mounting Dimensions

[Unit: mm]

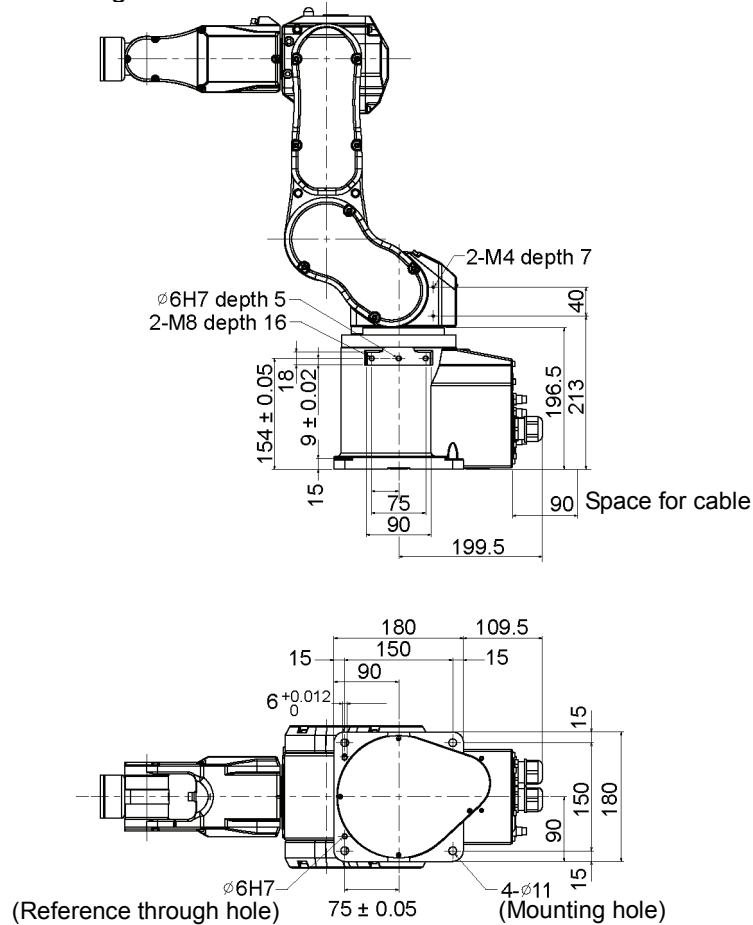

3.4 Installation

THE INSTALLATION SHALL BE MADE BY QUALIFIED INSTALLATION PERSONNEL AND SHOULD CONFORM TO ALL NATIONAL AND LOCAL CODES.

 WARNING	<ul style="list-style-type: none"> ■ To ensure safety, a safeguard must be installed for the robot system. For details on the safeguard, refer to the <i>Installation and Design Precautions</i> in the <i>Safety</i> chapter of the EPSON RC+ User's Guide. ■ Install the Manipulator at a location with sufficient space so that a tool or a work piece on the end effector does not reach a wall or a safeguard when the Manipulator extends its arm fully while holding a work piece. Installing the Manipulator at a location with insufficient space is extremely hazardous and may result in serious bodily injury and/or severe equipment damage to the robot system as a tool or a work piece may collide with a wall and a safeguard. ■ Anchor the Manipulator before turning ON the power to or operating the Manipulator. Turning ON the power to or operating the Manipulator that is not anchored is extremely hazardous and may result in serious bodily injury and/or severe equipment damage to the robot system as the Manipulator may fall down. ■ Before installing and operating the Manipulator, make sure that all parts of the Manipulator are in place and have no external defects. Missing or defective parts may cause improper operation of the Manipulator. Improper operation of the Manipulator is extremely hazardous and may result in serious bodily injury and/or severe equipment damage to the robot system.
--	--

 CAUTION	<ul style="list-style-type: none"> ■ The robot system must be installed to avoid interference with buildings, structures, utilities, other machines and equipment that may create a trapping hazard or pinch points.
--	---

Mounting bolt

There are 4 threaded holes for the Manipulator base. Use M8 mounting bolts conforming to the strength, ISO898-1 property class: 12.9. For the dimensions, refer to *Setup & Operation 3.3 Mounting Dimensions*.

Base table

A base table for anchoring the Manipulator is not supplied. Please make or obtain the base table for your Manipulator. The shape and size of the base table will differ depending on the use of the robot system. For your reference, we list some basic Manipulator table requirements here.

The base table must not only be able to bear the weight of the Manipulator but also be able to withstand the dynamic movement of the Manipulator when it operates at maximum acceleration. Ensure that there is enough strength on the base table by attaching reinforcing materials such as crossbeams.

The torque and reaction force produced by the movement of the Manipulator are as follows:

- Max. Horizontal rotating torque : 500 N·m
- Max. Horizontal reaction force : 800 N
- Max. Vertical rotating torque : 600 N·m
- Max. Vertical reaction force : 2500 N

The plate for the Manipulator mounting face should be 30 mm thick or more and made of steel to reduce vibration. The surface roughness of the steel plate should be 25 μm or less.

The base table must be secured on the floor to prevent it from moving.

The Manipulator must be installed horizontally.

When using a leveler to adjust the height of the base table, use a screw with M16 diameter or more.

Connector

If you are passing cables through the holes on the base table, see the figures below.
[unit : mm]

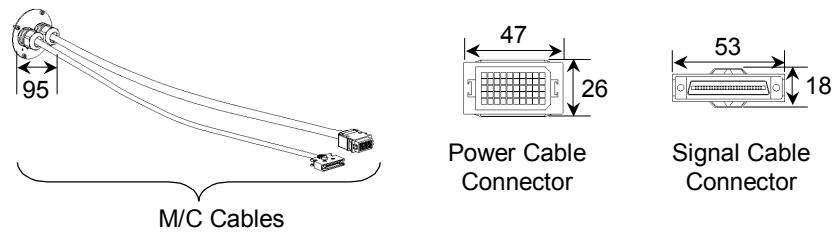

Do not remove the M/C cables from the Manipulator.



NOTE For environmental conditions regarding space when placing the Controller on the base table, refer to the Controller manual.

Cleanroom-model Manipulator

For the Cleanroom-model, follow the steps below before the installation.

- (1) Unpack it outside of the clean room.
- (2) Secure the Manipulator to delivery equipment such as a pallet with bolts so that the Manipulator does not fall.
- (3) Wipe off the dust on the Manipulator with a little alcohol or distilled water on a lint-free cloth.
- (4) Carry the Manipulator in the clean room.
- (5) Secure the Manipulator to the base table.
- (6) Connect an exhaust tube (\varnothing 8 mm) to the exhaust port.

3.5 Connecting the Cables

 WARNING	<ul style="list-style-type: none"> ■ Before performing any replacement procedure, turn OFF the Controller and related equipment, and then pull out the power plug from the power source. Performing any replacement procedure with the power ON is extremely hazardous and may result in electric shock and/or malfunction of the robot system. ■ Be sure to connect the AC power cable to a power receptacle. DO NOT connect it directly to a factory power source. To shut off power to the robot system, pull out the power plug from the power source. Performing any work while connecting the AC power cable to a factory power source is extremely hazardous and may result in electric shock and/or malfunction of the robot system. ■ Be sure to connect the cables properly. Do not allow unnecessary strain on the cables. (Do not put heavy objects on the cables. Do not bend or pull the cables forcibly.) The unnecessary strain on the cables may result in damage to the cables, disconnection, and/or contact failure. Damaged cables, disconnection, or contact failure is extremely hazardous and may result in electric shock and/or improper function of the robot system. ■ Before wiring, turn OFF the Controller and related equipment, and then pull up a warning sign (e.g. DO NOT TURN ON THE POWER.). Wiring with the power ON is extremely hazardous and may result in electric shock and/or malfunction of the robot system. ■ Grounding the manipulator is done by connecting with the controller. Ensure that the controller is grounded and the cables are correctly connected. If the ground wire is improperly connected to ground, it may result in the fire or electric shock.
--	---

 CAUTION	<ul style="list-style-type: none"> ■ When connecting the Manipulator and the Controller, make sure that the serial numbers on each equipment match. Improper connection between the Manipulator and Controller may not only cause improper function of the robot system but also safety problems. The connection method varies with the Controller used. For details on the connection, refer to the Controller manual. ■ Only authorized or certified personnel should be allowed to perform wiring. Wiring by unauthorized or uncertified personnel may result in bodily injury and/or malfunction of the robot system.
--	---

Cleanroom-model Manipulator

For the Cleanroom-model, an exhaust system is necessary. For details, refer to *Setup & Operation: 2.6 Specifications*.

Connect

Connect the power connector and signal connector of the M/C cables to the Controller.

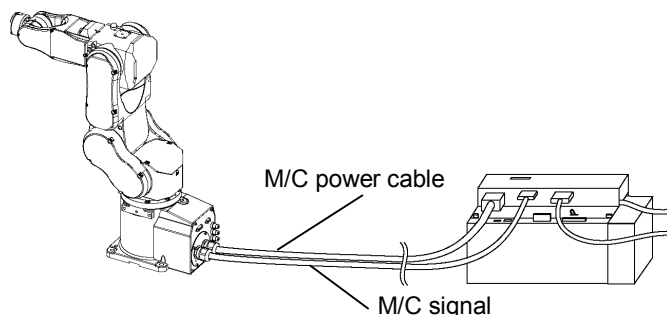

3.6 User Wires and Pneumatic Tubes

 CAUTION	<p>■ Only authorized or certified personnel should be allowed to perform wiring. Wiring by unauthorized or uncertified personnel may result in bodily injury and/or malfunction of the robot system.</p>
---	--

User electrical wires and pneumatic tubes are contained in the cable unit.

Electrical Wires

Rated Voltage	Allowable Current	Wires	Nominal Sectional Area	Outer Diameter	Note
AC/DC30 V	1 A	24	0.211 mm ²	ø8.3±0.3 mm	Shielded

		Maker	Standard	
9 pin	Suitable Connector	JAE	DE-9PF-N	(Solder type)
	Clamp Hood	JAE	DE-C8-J9-F2-1R	(Connector setscrew: #4-40 NC)

Pins with the same number, indicated on the connectors on both ends of the cables, are connected.

Pneumatic Tubes

Max. Usable Pneumatic Pressure	Pneumatic Tubes	Outer Diameter × Inner Diameter
0.59 MPa (6 kgf/cm ² : 86 psi)	4	ø4 mm × ø2.5 mm

Tubes with the same number, indicated in details of A and B, are connected.

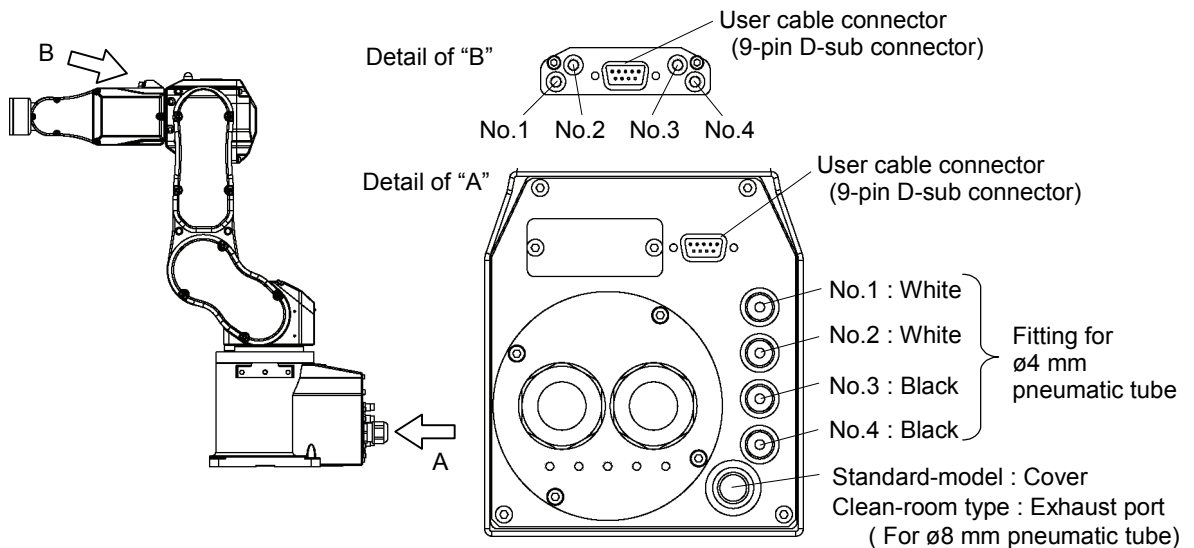

We prepare the part that can be mounted to the position shown in “Detail of B”.

One Touch Fittings Kit (Set of four: M5- \varnothing 4 mm one touch fittings for tubes)

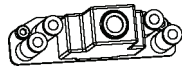
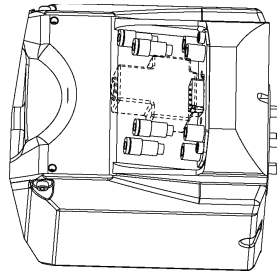

Straight

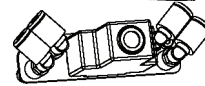
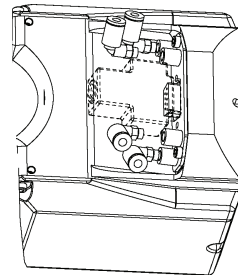

Elbow

User Connector kit (Single: 9 pins D-sub connector)

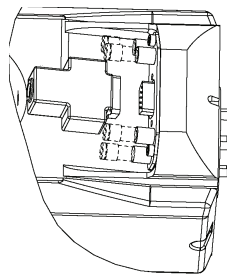

3.7 Checking the Basic orientation

After parts have been replaced (motors, reduction gear units, belts, etc.), the Manipulator cannot operate properly because a mismatch exists between the origin stored in each motor and its corresponding origin stored in the Controller.

The process of aligning the two origins is called “Calibration”.

At shipment, the following basic orientation is configured as origin.

After all setting is done, go through an origin return run and make sure the manipulator moves to the right basic orientation.

To make the manipulator return to origin, select the [Tool]-[Robot Manager]-[Control Panel] and click the <Home> button.

If the manipulator cannot be in the basic orientation after the origin return run (not like as the figure below), refer to Maintenance 16. Calibration to calibrate the manipulator.

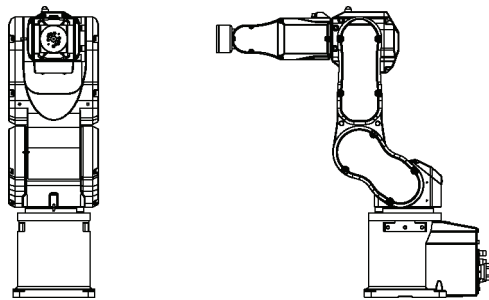

Basic orientation

4. End Effectors

4.1 Attaching an End Effector

Create an end effector for your Manipulator that will attach to Arm #6. Before attaching the end effector to the end of Arm #6, observe these guidelines.

 CAUTION	<ul style="list-style-type: none"> ■ If you use an end effector equipped with a gripper or chuck, connect wires and/or pneumatic tubes properly so that the gripper does not release the work piece when the power to the robot system is turned OFF. Improper connection of the wires and/or pneumatic tubes may damage the robot system and/or work piece as the work piece is released when the Emergency Stop switch is pressed. I/O outputs are configured at the factory so that they are automatically shut off (0) by power disconnection, the Emergency Stop switch, or the safety features of the robot system.
---	--

Wrist Flange

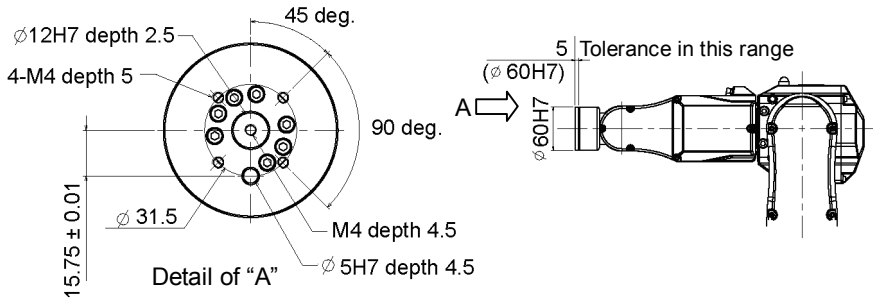

Arm #6

Attach an end effector to the end of the Arm #6 using an M4 bolt.

Layouts

When you operate the Manipulator with an end effector, the end effector may interfere with the Manipulator because of the outer diameter of the end effector, the size of the work piece, or the position of the arms. When designing your system layout, pay close attention to the interference area of the end effector.

Standard specification (Brakes on Joints #2, #3, #5)

When the end effector is mounted, the joint may rotate by the hand weight or inertia in Emergency Stop status. The end effector may contact the manipulator body depending on the diameter of end effector, size of part, or arm position. Be careful about the area of interference of the end effector for the system layout.

Compatibility with PS series

To mount the end effector used in the PS series to the C3 series, we prepare the option – PS Compatible Plate. For details of the option, refer to *Setup & Operation: 6. Options*.

4.2 Attaching Camera and Valves

Decks are equipped to Arms #3 and #5 to enable the easy installation of air valve.

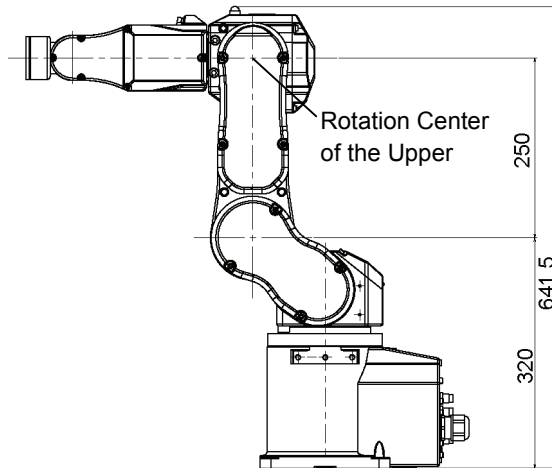
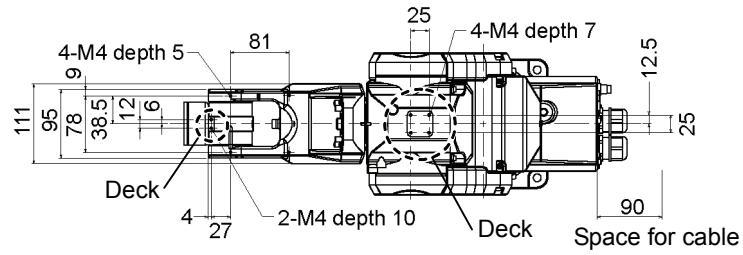

[Unit: mm]

For details of the payload exceeding 3 kg, refer to the section “*Restriction on payload exceeding 3 kg (more than 3 kg and less than or equal to 5 kg)*” in the *Setup & Operation 4.3.1 WEIGHT Setting*.

To mount the camera, the camera plate unit is necessary.

We prepare the option – Camera Plate Unit. For details of the option, refer to *Setup & Operation: 6. Options*.

4.3 WEIGHT and INERTIA Settings

The WEIGHT and INERTIA commands are for setting the load parameters of the Manipulator. These settings optimize the Manipulator motion.

WEIGHT Setting

The WEIGHT command is for setting the load weight. The more the load weight increases, the more the speed and acceleration/deceleration for the Manipulator movement are reduced.

INERTIA Setting

The INERTIA command is for setting the moment of inertia and the eccentricity of the load. The more the moment of inertia increases, the more the acceleration and deceleration of the Arm #6 are reduced. The more the eccentricity increases, the more the acceleration and deceleration for the Manipulator movement are reduced.

To ensure optimum Manipulator performance, it is important to make sure that the load (weight of the end effector and work piece) and moment of inertia of the load are within the maximum rating for the Manipulator, and that Arm #6 does not become eccentric.

If the load or moment of inertia exceed the ratings or if the load becomes eccentric, follow the steps in the *Setup & Operation 4.3.1 WEIGHT Setting* and *4.3.2 INERTIA Setting*, to set parameters.

Setting parameters makes the operation of the Manipulator optimal, reduces vibration to shorten the operating time, and improves the capacity for larger loads. In addition, it reduces persistent vibration produced when the moment of inertia of the end effector and work piece is bigger.

The allowable weight for C3 Manipulators is up to 3 kg (5 kg*). However, the moment and the moment of inertia should also be considered due to limitations for these factors.

If force is applied to the Manipulator instead of the weight, force on the Arms #4, #5, and #6 should be within the values shown in the table “Allowable Moment and Moment of Inertia for C3 Manipulators”.

* When the load of the Manipulator is more than 3 kg and less than or equal to 5 kg, refer to the section “*Restriction on payload exceeding 3 kg (more than 3 kg and less than or equal to 5 kg)*” in the *Setup & Operation 4.3.1 WEIGHT Setting*.

Allowable Moment and Moment of Inertia for C3 Manipulators

Arm	Allowable Moment *1	GD ² /4 Allowable Moment of Inertia
#4	4.41 N·m (0.45 kgf·m)	0.15 kg·m ²
#5 *2	4.41 N·m (0.45 kgf·m)	0.15 kg·m ²
#6	2.94 N·m (0.3 kgf·m)	0.1 kg·m ²

*1 Gravitational unit

*2 The allowable moment and allowable moment of inertia of Arm #5 are calculated by the distance from the Arm #5 rotation center (a + 65 mm). (Refer to the figure in the “Critical Location of the Load on C3 Manipulators”).

Critical Location of the Load on C3 Manipulators

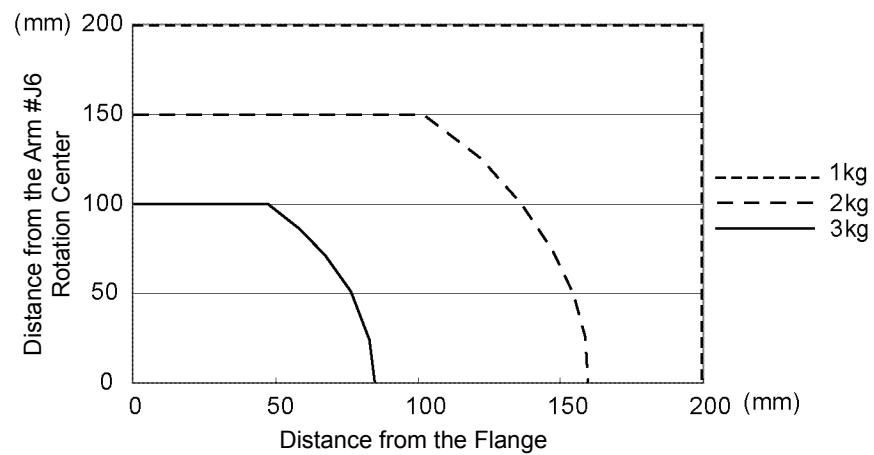
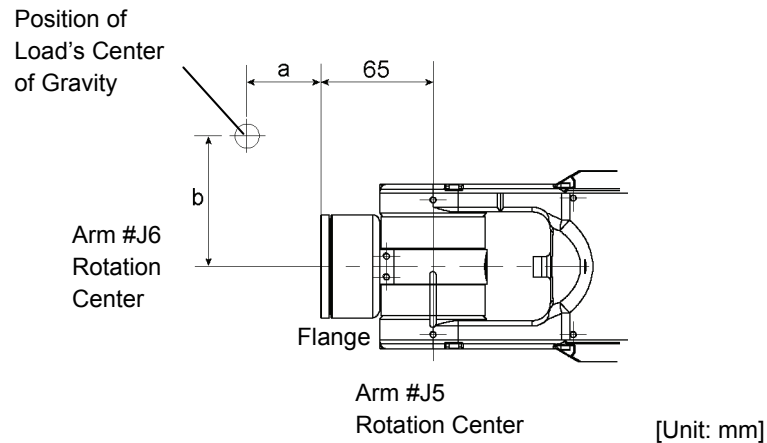

When calculating the critical location of the load on the Arm #5 using the allowable moment and allowable moment of inertia, the calculated value represents a distance from the Arm #5 rotation center, not the distance from the flange. Therefore, to get a value of the critical location of the load on Arm #5, subtract 65 (mm) from the calculated distance from the Arm #5 rotation center as shown the example below.

Example: Calculate the critical location of the load on the Arm #5 (c) when a 2.5 kg load is on the Arm #6 rotation center line (b = 0).

$$\begin{aligned} & \text{Allowable Moment of the Arm \#5 (N}\cdot\text{m)} / \text{Load (kg)} \\ &= \text{Distance from the Arm \#5 rotation center (m)} \\ & 4.41 \text{ (N}\cdot\text{m)} / 9.8 / 2.5 \text{ (kg)} = 0.18 \rightarrow 0.18 \text{ (m)} = 180 \text{ (mm)} \end{aligned}$$

$$\begin{aligned} c \text{ (mm)} &= \text{Distance from the Arm \#5 rotation center (mm)} - 65 \text{ (mm)} \\ c &= 180 \text{ (mm)} - 65 \text{ (mm)} = 115 \text{ (mm)} \end{aligned}$$

Moment

A moment is a necessary torque (holding torque) to counteract the gravity affecting the load.

Design an end effector so that the eccentric quantity at the position where the load is attached is within the allowable moment.

A maximum torque (T) is calculated by the following formula.

$$T = m \text{ (kg)} \times L \text{ (m)} \times g \text{ (m/s}^2\text{)}$$

- m: Weight of load (kg)
- L: Eccentric quantity of load (m)
- g: Gravitational acceleration (m/s²)

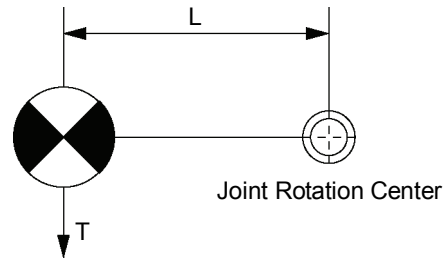

Max. Eccentric Quantity of Load

(Distance between the joint rotation center and the load's center of gravity)

Axis	WEIGHT 1 kg	WEIGHT 2 kg	WEIGHT 3 kg
#4	200 mm	200 mm	150 mm
#5	200 mm	200 mm	150 mm
#6	200 mm	150 mm	100 mm

(The maximum eccentric quantity of load is restricted to 200 mm or less.)

4.3.1 WEIGHT Setting



CAUTION

- Set the total weight of the end effector and the work piece to 3 kg or less. The C3 Manipulators can operate without limitations on the condition that the load of the Manipulator should be 3 kg or less. When the payload of the Manipulator is more than 3 kg and less than or equal to 5 kg, refer to the section “Restrictions on payload exceeding 3 kg (more than 3 kg and less than or equal to 5 kg)” in the later part of this section for details. Always set the Weight parameters of the WEIGHT command according to the load. Setting a value that is smaller than the actual load may cause errors, excessive shock, insufficient function of the Manipulator, and/or shorten the life cycle of parts/mechanisms.

The acceptable weight capacity (end effector and work piece) for C3 Manipulators is 1 kg nominal rating and 3 (5) kg maximum*. When the load (weight of the end effector and work piece) exceeds the rating, change the setting of the Weight parameter.

After the setting of the Weight parameter is changed, the maximum acceleration/deceleration and speed of the robot system corresponding to the Weight parameter is set automatically.

* When the payload of the Manipulator is more than 3 kg and less than or equal to 5 kg, refer to the section “Restrictions on payload exceeding 3 kg (more than 3 kg and less than or equal to 5 kg)” in the later part of this section for details.

Setting method of Weight parameters

The method for setting Weight parameter varies with the software used.

EPSON
RC+

EPSON RC+ 5.0 (RC180) / EPSON RC+ 6.0 (RC620)

Enter into the [Weight:] text box on the [Weight] panel ([Tools]-[Robot Manager]).

You may also execute the Weight command from [Command Window].

Load on the Manipulators

The Manipulator can load valves or any other devices onto the following three points.

Top View

Load on the
Fore - end of Arm #6

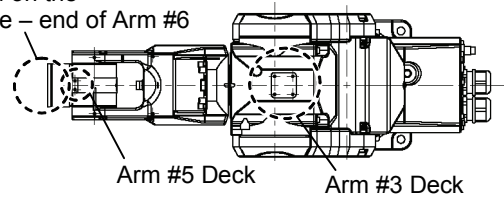

Deck detailed

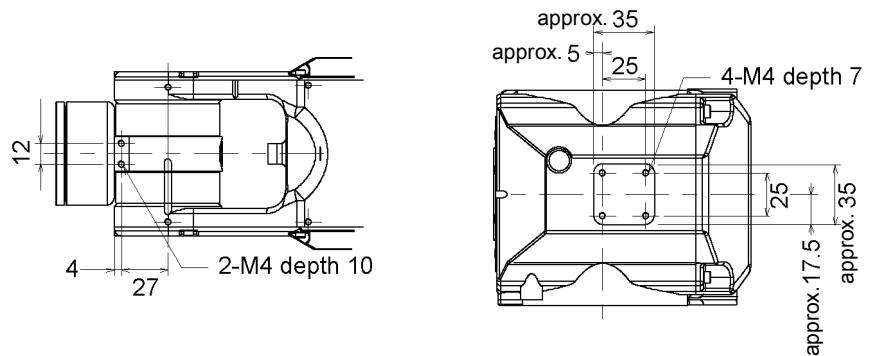

Arm #5 Deck

Arm #3 Deck

[Unit: mm]

When you attach the equipment to the decks on the upper arm, convert its weight into equivalent weight assuming that the equipment is attached to the end of the Arm #6. Then, this equivalent weight added to the load will be a Weight parameter.

Calculate the Weight parameter by following the formula below and enter the value.

Weight Parameter Formula

$$\text{Weight parameter} = M_w + W_a + W_b$$

M_w : Load on the fore-end of Arm #6 (kg)

W_a : Equivalent weight of the Arm #3 deck (kg)

W_b : Equivalent weight of the Arm #5 deck (kg)

$$W_a = M_a (L_a)^2 / (L)^2$$

$$W_b = M_b (L_b)^2 / (L)^2$$

M_a : Weight of the air valve on the Arm #3 deck

M_b : Weight of the camera on the Arm #5 deck

L : Length of the upper arm (315 mm)

L_a : Distance between the Joint #3 and the center of gravity of the air valve on the Arm #3 deck (mm)

L_b : Distance between the Joint #3 and the center of gravity of the camera on the Arm #5 deck (mm)

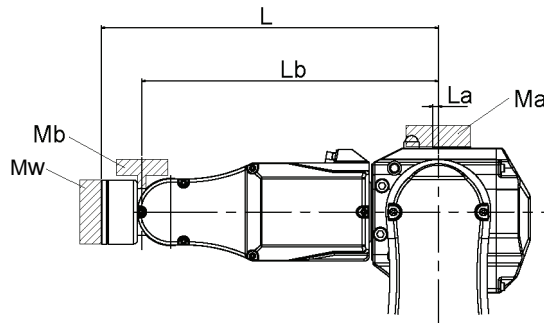

<Example> The fore-end of Arm #6 is 315 mm (L) away from the Joint #3.

Load on the fore-end of Arm #6 is 1 kg (M_w).

Load on the Arm #3 deck is 1.5 kg (M_a).

The deck is 0 mm (L_a) away from Joint #3.

Load on the Arm #5 deck is 0.5 kg (M_b).

The deck is 280 mm (L_b) away from the Joint #3.

$$W_a = 1.5 \times 0^2 / 315^2 = 0$$

$$W_b = 0.5 \times 280^2 / 315^2 = 0.395 \rightarrow 0.4 (\text{round up})$$

$$M_w + W_a + W_b = 1 + 0 + 0.4 = 1.4$$

Enter “1.4” for the Weight parameter.

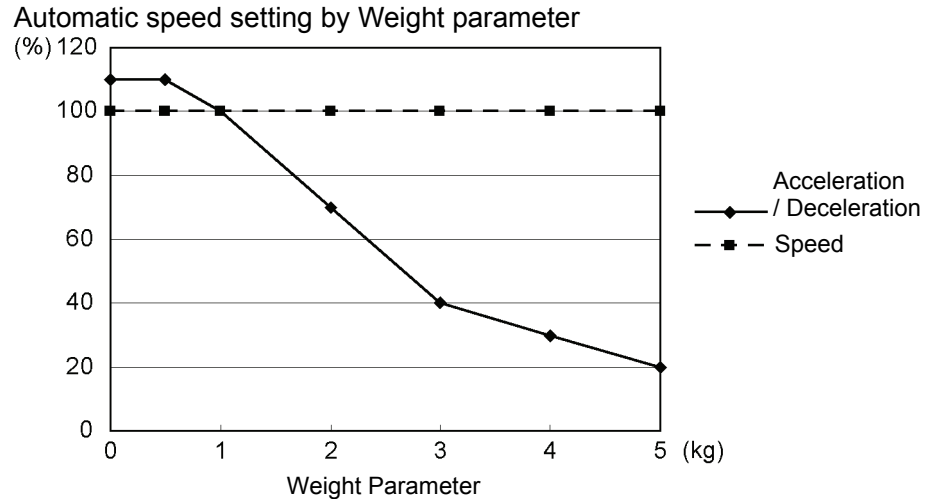

- * The percentage in the graph is based on the speed at rated weight (1 kg) as 100%.
- * When the payload of the Manipulator is more than 3 kg and less than or equal to 5 kg, refer to the section “Restrictions on payload exceeding 3 kg (more than 3 kg and less than or equal to 5 kg)” in the later part of this section for details.

Restrictions on payload exceeding 3 kg

(more than 3 kg and less than or equal to 5 kg)

Although the maximum payload of the C3 Manipulator is 3 kg, you can increase up to 5 kg when you restrict the arm pose range of Arm #5 with arm downward positioning.

When the load is over 3 kg, the Arm #5 orientation must be within the angle indicated in the following graph.

The graph shows the relation of the load weight and Arm #5 angle limit (A^1) measured in vertical direction (direction of gravity). Note that the heavier load Arm #6 holds, the smaller the angle limit becomes.

When the manipulator operates vertically to the operating surface, the limit of Arm #5 is equivalent to the limit of operating angle (A^2).

In addition, for the eccentric load, the angle limit is an angle of the line joining the center of load and Arm #5 rotation axis with the vertical direction (B).

The eccentric quantity of load should be within the allowable moment and the allowable moment of inertia of Arms #4, #5, and #6.

Relation of load weight and Arm #5 angle limit

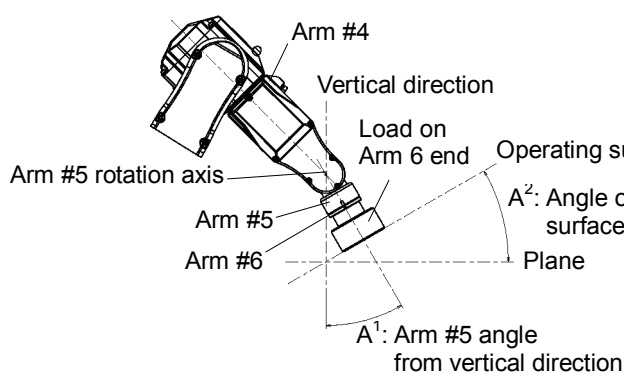
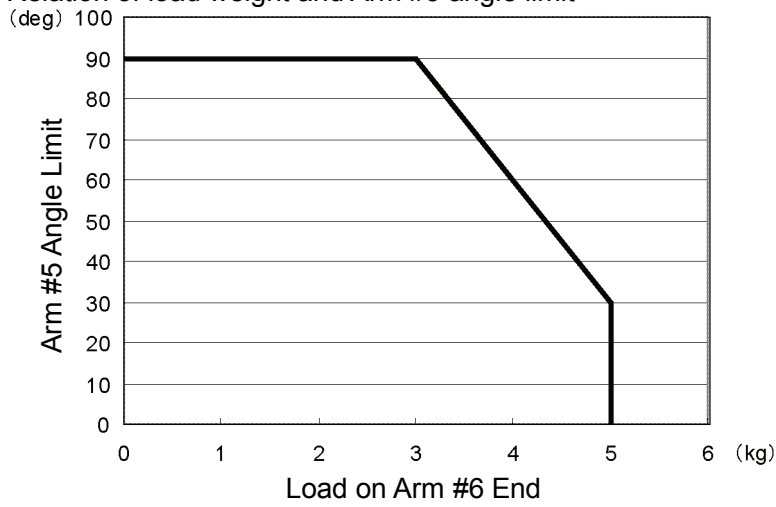

Relation of Arm #5 angle and operating surface

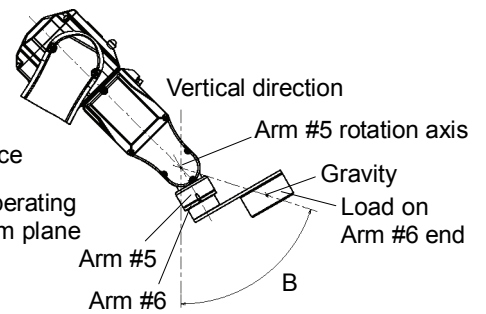

Angle limit for eccentric load

4.3.2 INERTIA Setting

Moment of Inertia and the INERTIA Setting

The moment of inertia is defined as “the ratio of the torque applied to a rigid body and its resistance to motion”. This value is typically referred to as “the moment of inertia”, “inertia”, or “GD²”. When the Manipulator operates with objects such as an end effector attached to the Arm #6, the moment of inertia of load must be considered.

 CAUTION	<ul style="list-style-type: none"> ■ The moment of inertia of load (weight of the end effector and work piece) must be 0.1 kg·m² or less. The C3 Manipulators are not designed to work with moment of inertia exceeding 0.1 kg·m². Always set the moment of inertia (INERTIA) parameter according to the moment of inertia. Setting a value that is smaller than the actual moment of inertia may cause errors, excessive shock, insufficient function of the Manipulator, and/or shorten the life cycle of parts/mechanisms.
---	--

The acceptable moment of inertia of load in C3 Manipulator is 0.1 kg·m² nominal rating and 0.1 kg·m² maximum. When the moment of inertia of load exceeds the rating, change the setting of the moment of inertia using the INERTIA command. After the setting has been changed, the maximum acceleration/deceleration speed of Arm #6 responding to “moment of inertia” is set automatically.

Moment of inertia of load on Arm #6

The moment of inertia of load (weight of the end effector and work piece) on Arm #6 can be set by the “moment of inertia (INERTIA)” parameter of the INERTIA command. The method for setting the parameter varies with the software used.

**EPSON
RC+**

EPSON RC+ 5.0 (RC180) / EPSON RC+ 6.0 (RC620)

Enter into the [Load inertia:] text box on the [Inertia] panel ([Tools]–[Robot Manager]). You may also execute the Inertia command from [Command Window].

Eccentric Quantity and the INERTIA Setting

 CAUTION	<ul style="list-style-type: none"> ■ The eccentric quantity of load (weight of the end effector and work piece) must be 200 mm or less. The C3 Manipulators are not designed to work with eccentric quantity exceeding 200 mm. Always set the eccentric quantity parameter according to the eccentric quantity. Setting a value that is smaller than the actual eccentric quantity may cause errors, excessive shock, insufficient function of the Manipulator, and/or shorten the life cycle of parts/mechanisms.
---	---

The acceptable eccentric quantity of load in C3 Manipulators is 30 mm nominal rating and 200 mm maximum. When the eccentric quantity of load exceeds the rating, change the setting of eccentric quantity parameter using the INERTIA command. After the setting has been changed, the maximum acceleration/deceleration speed of Manipulator corresponding to “eccentric quantity” is set automatically.

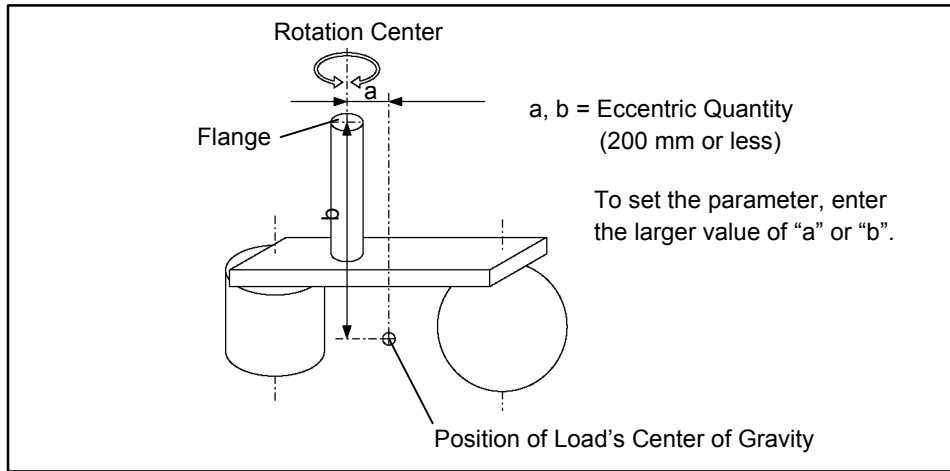

Eccentric Quantity

Eccentric quantity of load on Arm #6

The eccentric quantity of load (weight of the end effector and work piece) on Arm #6 can be set by the “eccentric quantity” parameter of the INERTIA command.

Enter the larger value of “a” or “b” in the figure above to the [Eccentricity] text box.

The method for setting the parameter varies with the software used.



EPSON RC+ 5.0 (RC180) / EPSON RC+ 6.0 (RC620)

Enter into the [Eccentricity:] text box on the [Inertia] panel ([Tools]–[Robot Manager]).

You may also execute the Inertia command from [Command Window].

Automatic acceleration/deceleration setting by INERTIA (eccentric quantity)

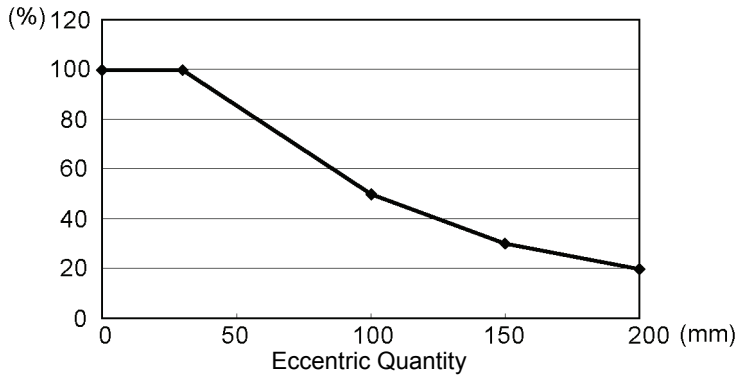

* The percentage in the graph is based on the acceleration/ deceleration at rated eccentricity (30 mm) as 100%.

INERTIA (eccentric quantity) is affected by the load setting. When you configure the load setting, refer to *Setup & Operation 4.3: WEIGHT and INERTIA Settings* and determine it carefully.

Calculating the Moment of Inertia

Refer to the following examples of formulas to calculate the moment of inertia of load (end effector with work piece).

The moment of inertia of the entire load is calculated by the sum of each part (a), (b), and (c).

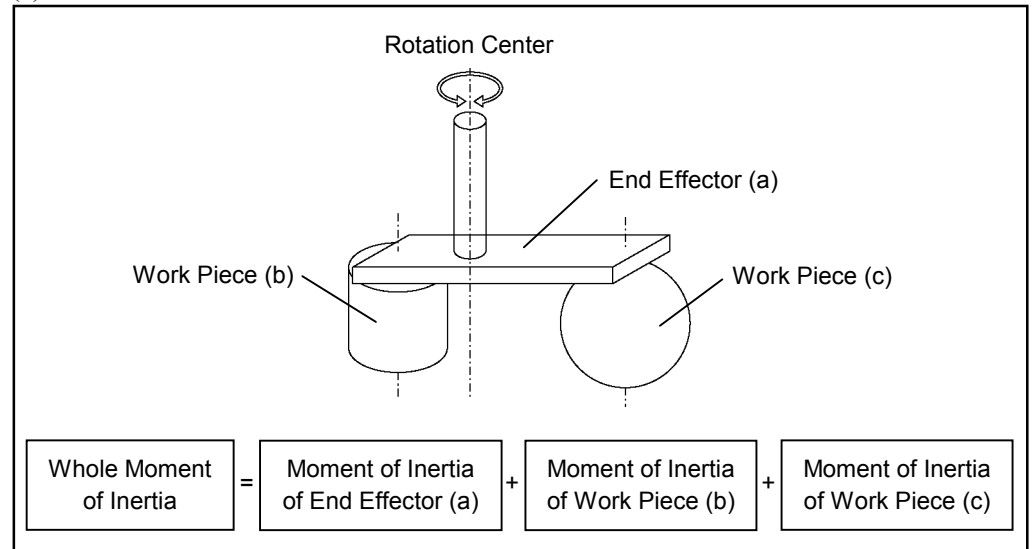

The methods for calculating the moment of inertia for (a), (b), and (c) are shown on this page or the next page. Find the whole moment of inertia using the basic formulas on the next page.

(a) Moment of inertia of a rectangular parallelepiped

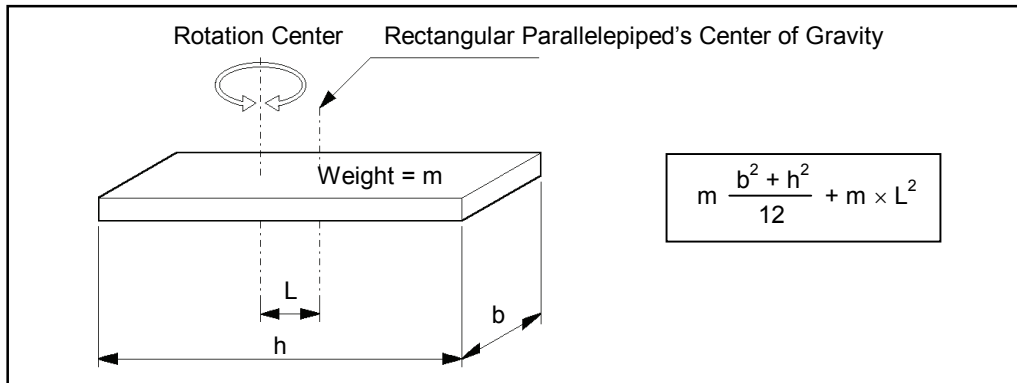

(b) Moment of inertia of a cylinder

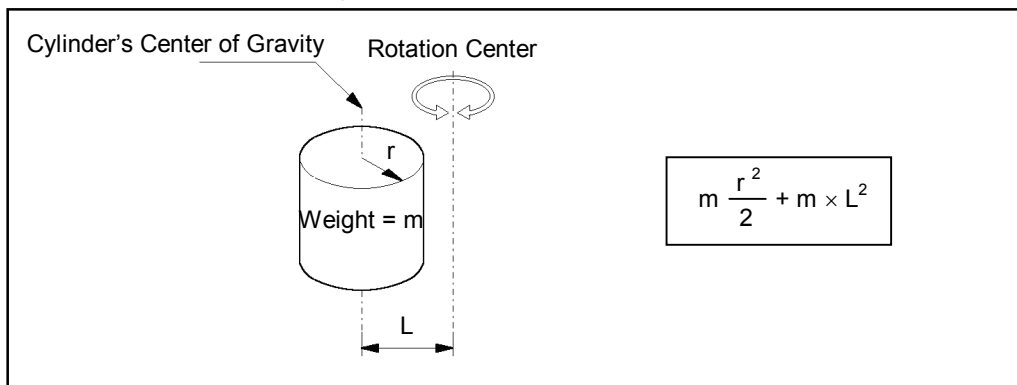

(c) Moment of inertia of a sphere

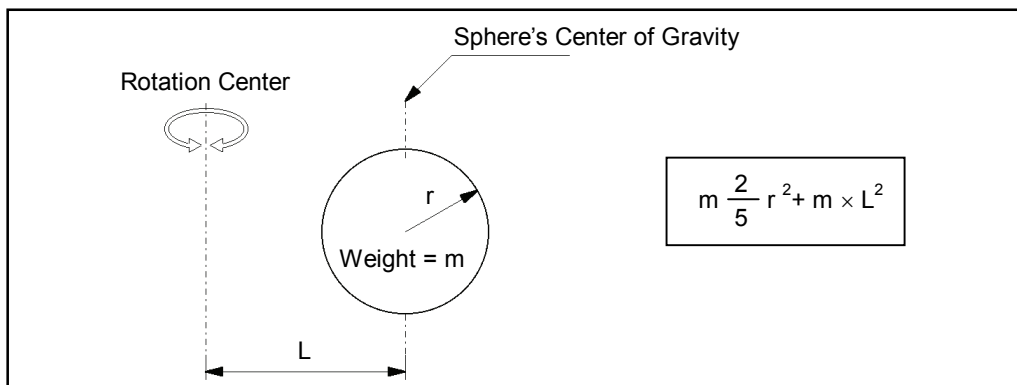

4.4 Precautions for Auto Acceleration/Deceleration

The speed and acceleration/deceleration of the Manipulator motion are automatically optimized according to the values of WEIGHT and INERTIA and the Manipulator's postures.

WEIGHT Setting

The speed and acceleration/deceleration of the Manipulator are controlled according to the load weight set by the WEIGHT command.

The more the load weight increases, the more the speed and acceleration/deceleration are reduced to prevent residual vibration.

INERTIA Setting

The acceleration/deceleration of Arm #6 are controlled according to the moment of inertia set by the INERTIA command. The acceleration/deceleration of the whole Manipulator are controlled according to the eccentricity set by the INERTIA command. The more the moment of inertia and eccentricity of the load increase, the more the acceleration/deceleration are reduced.

Auto Acceleration/Deceleration According to Manipulator's Posture

The acceleration/deceleration are controlled according to the Manipulator's posture. When the Manipulator extends its arms or when the movement of the Manipulator produces vibration frequently, the acceleration/deceleration are reduced.

Set appropriate values for WEIGHT and INERTIA so that the Manipulator operation is optimized.

5. Motion Range

 WARNING	<ul style="list-style-type: none"> When setting up the motion range for safety, both the pulse range and mechanical stops must always be set at the same time. Failure to set both of them together may cause serious safety problems.
---	---

The motion range is preset at the factory as explained in the *Setup & Operation 2.5 Standard Motion Range*. This is the maximum motion range of the Manipulator.

There are three methods for setting the motion range described as follows:

- Setting by pulse range (for all arms)
- Setting by mechanical stops
- Setting the Cartesian (rectangular) range in the X, Y coordinate system of the Manipulator

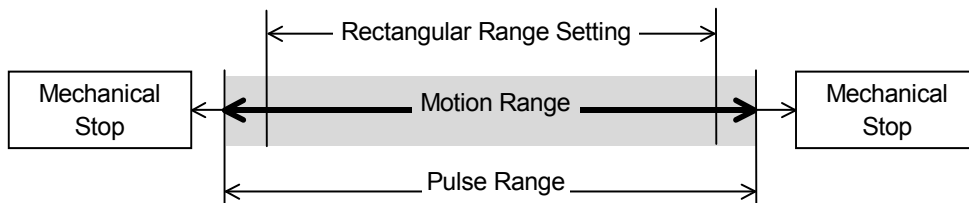

When the motion range is changed due to layout efficiency or safety, follow the descriptions in 5.1 to 5.4 to set the range.

5.1 Motion Range Setting by Pulse Range (for All Arms)

Pulses are the basic unit of Manipulator motion. The motion range of the Manipulator is controlled by the pulse range between the pulse lower limit and upper limit of each axis. Pulse values are read from the encoder output of the servo motor. The pulse range must be set inside of the mechanical stop range.

 CAUTION	<ul style="list-style-type: none"> Do not set and/or use the Arm #4 with pulse range beyond the maximum value. The Arm #4 does not have a mechanical stop. The used of Arm #4 in motion exceeding the maximum pulse range may cause inner wiring damage to and/or malfunction of the Manipulator.
---	--

You can check the inner wiring torsion by removing the Arm #3 cover.

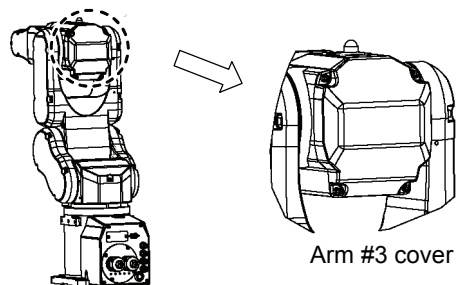



Once the Manipulator receives an operating command, it checks whether the target position specified by the command is within the pulse range before operating. If the target position is out of the set pulse range, an error occurs and the Manipulator does not move.

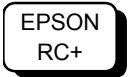

EPSON RC+ 5.0 (RC180) / EPSON RC+ 6.0 (RC620)
The pulse range can be set on the [Range] panel shown by selecting the [Tools]-[Robot manager].
You may also execute the Range command from the [Command Window].

5.1.1 Max. Pulse Range of Arm #1

Counterclockwise pulse values are positive (+) and clockwise pulse values are negative (-).

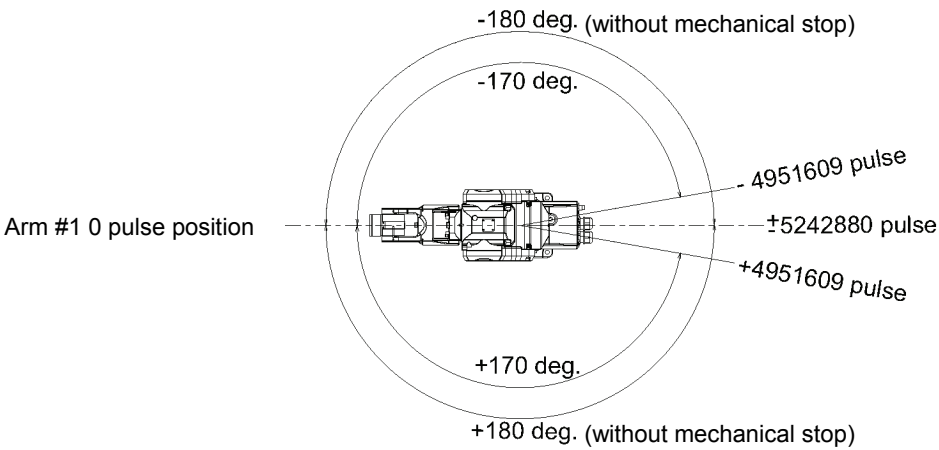

5.1.2 Max. Pulse Range of Arm #2

Counterclockwise pulse values are positive (+) and clockwise pulse values are negative (-).

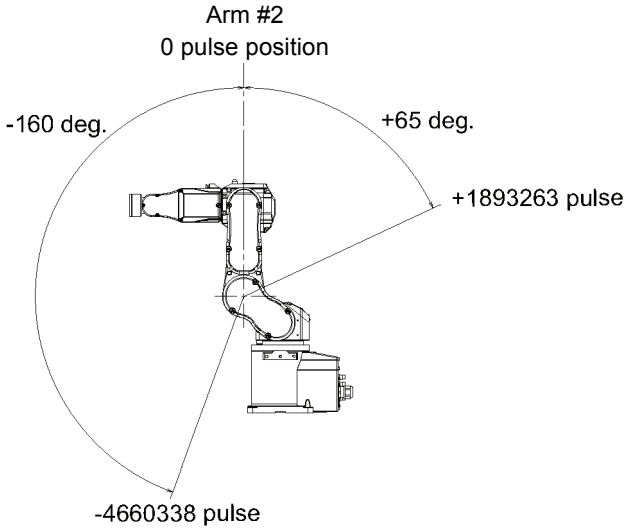

5.1.3 Max. Pulse Range of Arm #3

Counterclockwise pulse values are positive (+) and clockwise pulse values are negative (-).

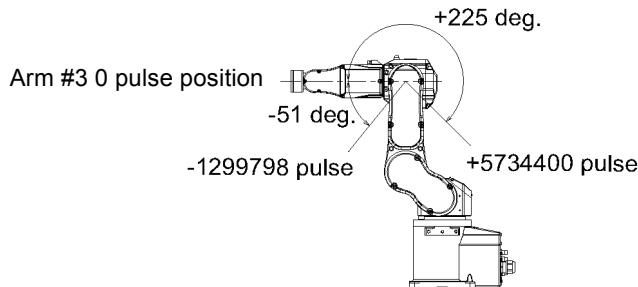

5.1.4 Max. Pulse Range of Arm #4

From the angle of arm end, clockwise pulse values are positive (+) and counterclockwise pulse values are negative (-).

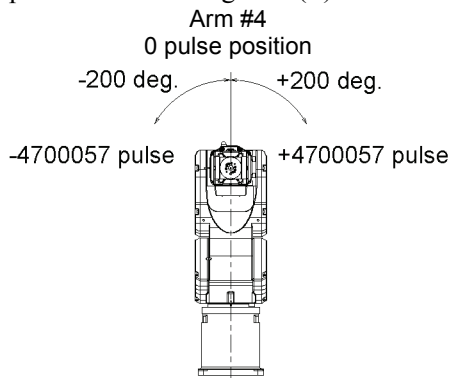

CAUTION

- Do not set and/or use the Arm #4 with pulse range beyond the maximum value. The Arm #4 does not have a mechanical stop. The used of Arm #4 in motion exceeding the maximum pulse range may cause inner wiring damage to and/or malfunction of the Manipulator.

You can check the inner wiring torsion by removing the Arm #3 head cover.

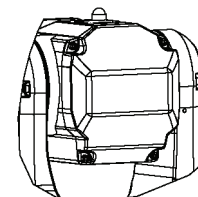
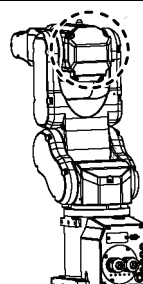

Arm #3 head cover

5.1.5 Max. Pulse Range of Arm #5

Counterclockwise pulse values are positive (+) and clockwise pulse values are negative (-).

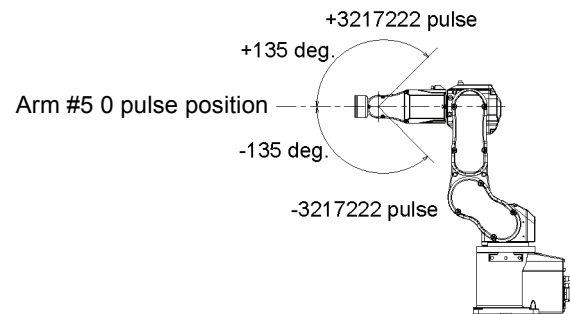

5.1.6 Max. Pulse Range of Arm #6

From the angle of arm end, clockwise pulse values are positive (+) and counterclockwise pulse values are negative (-).

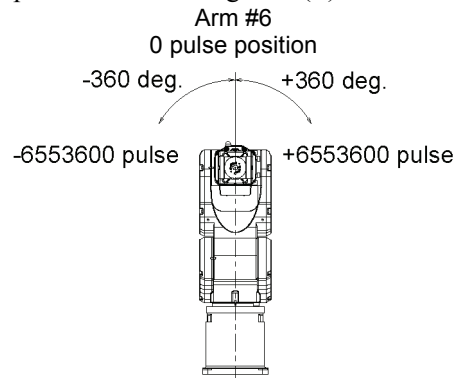

5.2 Motion Range Setting by Mechanical Stops

Mechanical stops physically limit the absolute area that the Manipulator can move.

Be sure to turn OFF the Controller in advance.

Bolts are not provided, arrange for them by yourself.

Use a bolt conforming to the strength specified by ISO-898-1, property class: 12.9.

Re-specify the pulse range after changing the position of the mechanical stop.

For details on the pulse range setting, refer to the *Setup & Operation 5.1 Motion Range Setting by Pulse Range (for All Arms)*.

Be sure to set the pulse range without exceeding the pulse values corresponding to the mechanical stop's setting angles.

5.2.1 Motion Range Setting of Arm #1

There are threaded holes corresponding to each angle on the Manipulator.

Normally a mechanical stop is equipped in [b].

[a] and [c] limit the one side of motion range.

If the motion range of Arm #1 is ± 180 deg, remove the bolts below.

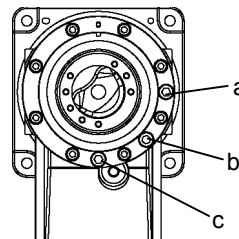

M8×15 hexagon socket head cap bolt
Tightening torque 3720 N·cm (380 kgf·cm)

	a	b		c
Angle (deg.)	-125	± 170	± 180	+125
Pulse (pulse)	-3640889	± 4951609	± 5242880	-3640889
Bolt	Applied	Applied (Normal)	Not applied	Applied

5.2.2 Motion Range Setting of Arm #2

There are threaded holes corresponding to each angle on the Manipulator.

Normally there is no mechanical stop equipped.

(-160 deg. - +65 deg.)

[d] and [e] limit the one side of motion range.

M10×15 hexagon socket head cap bolt
Tightening torque 7350 N·cm (750 kgf·cm)

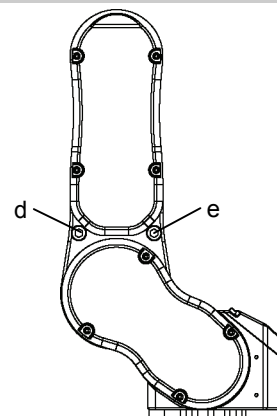

	d	e	-	-
Angle (deg.)	-143	+48	-160	+65
Pulse (pulse)	-4165177	+1398102	-4660338	+1893263
Bolt	Applied	Applied	Not applied (Normal)	Not applied (Normal)

5.2.3 Motion Range Setting of Arm #3

There are threaded holes corresponding to each angle on the Manipulator.

Normally mechanical stops are equipped to [g] and [h].

(+225 deg. - -51 deg.)

M8×12 hexagon socket head cap bolt
Tightening torque 3720 N·cm (380 kgf·cm)

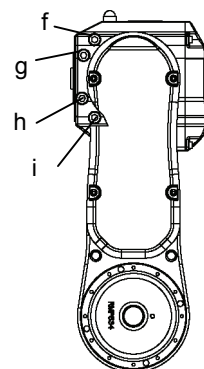

	f	i	g	h
Angle (deg.)	+201	-27	+225	-51
Pulse (pulse)	+5122731	-688128	+5734400	-1299798
Bolt	Applied	Applied	Applied (Normal)	Applied (Normal)

5.3 Restriction of Manipulator Operation by Joint Angle Combination

To prevent the arms of the Manipulator from interfering each other, the Manipulator operation is restricted in the specified motion range according to the joint angle combination of the Arm #1, #2, and #3.

The Manipulator operation is restricted and the Manipulator stops when the joint angles of the Arm are within the gray areas in the following figure.

Combination of Joint #1 and #2

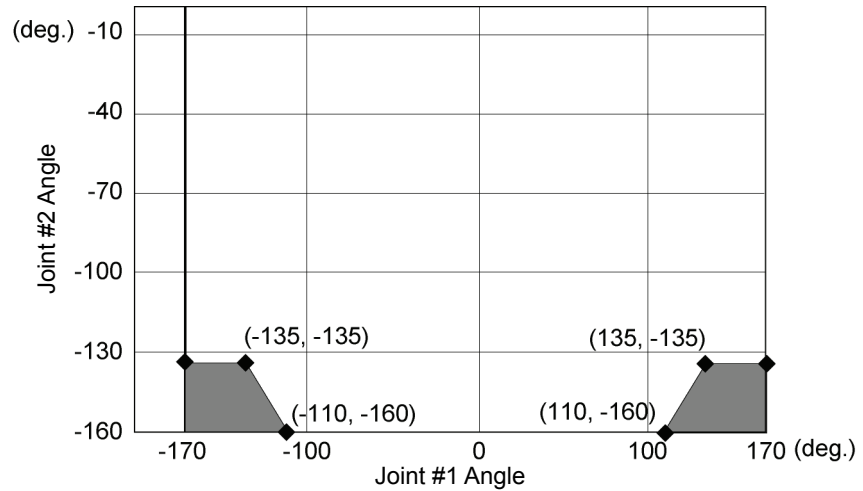

Combination of Joint #2 and #3

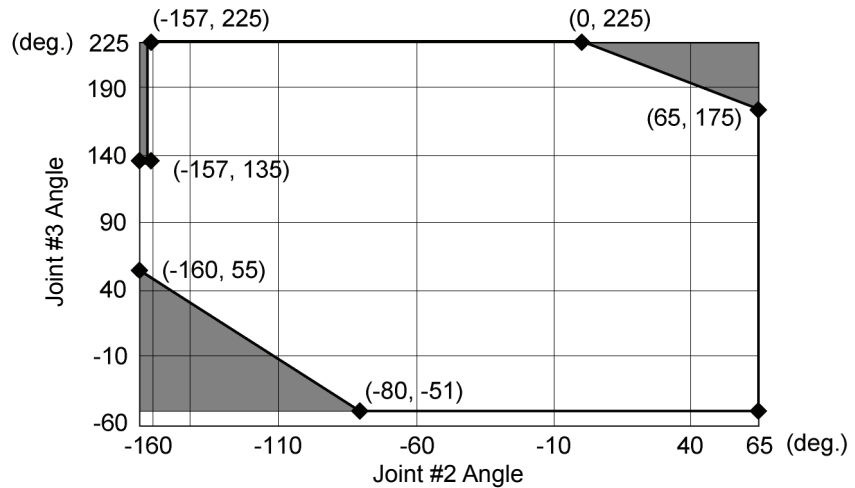

The restriction to Manipulator operation is enabled:

- During CP motion command execution
- You attempt to execute the motion command for moving the Manipulator to a target point (or pose) in the specified motion range.

The restriction to the Manipulator operation is disabled:

- The Arms of the Manipulator momentarily go through the specified motion range during the PTP motion command execution even though the joint angles of the Arms are in the gray areas of the figures above.

5.4 Coordinate System

The origin point is located where the Manipulator base intersects with the rotation axis of Joint #1.

For details on the coordinate system, refer to the *EPSON RC+ Users Guide manual*.

Table Top mounting

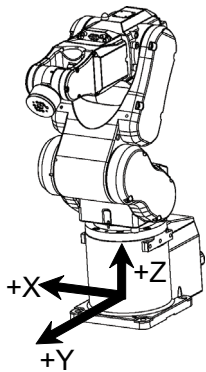

Ceiling mounting

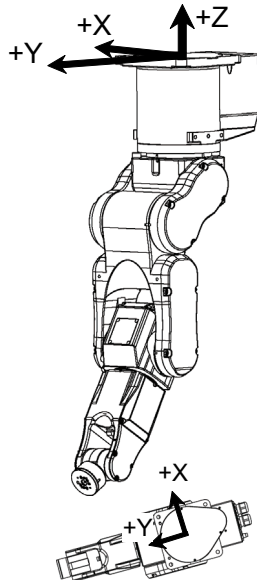

Wall mounting

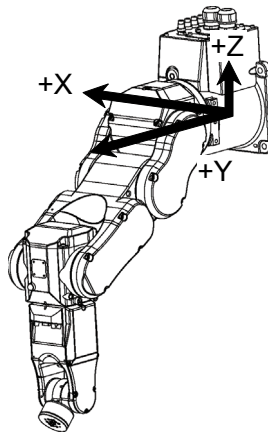

Skewed mounting

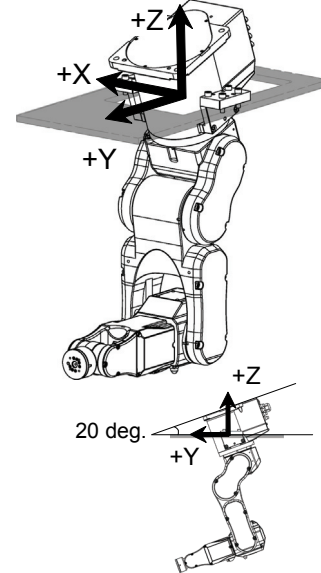

5.5 Setting the Cartesian (Rectangular) Range in the XY Coordinate System of the Manipulator

The Cartesian (rectangular) range in the XY coordinate system of the Manipulator is specified by the limited Manipulator operation area and the XYLIM setting.

The limited Manipulator operation area is defined so that the end effector does not interfere with the rear side of the Manipulator. The XYLIM setting is that you can set the upper and lower limits of the X and Y coordinates.

The limited Manipulator operation area and XYLIM setting apply only to the software. Therefore, these settings do not change the physical range. The maximum physical range is based on the position of the mechanical stops.

These settings are disabled during a joint jogging operation. Therefore, be careful not to allow the end effector to collide with the Manipulator or peripheral equipment.

The method for changing the XYLIM setting varies with the software used.

EPSON
RC+

EPSON RC+ 5.0 (RC180) / EPSON RC+ 6.0 (RC620)

Set the XYLIM setting on the [XYZ Limits] panel shown by selecting the [Tools]-[Robot manager].

You may also execute the XYLim command from the [Command Window].

6. Options

The C3 series has the options below.

- 6.1 Brake Release Unit
- 6.2 Camera Mounting Plate
- 6.3 PS Compatible Plate
- 6.4 Base Side Angled Fittings
- 6.5 Base Side Fittings

6.1 Brake Release Unit

With the electromagnetic brake is ON (such as in Emergency Stop status), you cannot move the Arms #2, #3, #5 by hand. If the all joints have a brake, all arms don't move.

You can move Arms by hand using the brake release unit while the controller power is OFF or right after unpacking.

 WARNING	<ul style="list-style-type: none"> ■ Before connecting/disconnecting the connector of Brake release unit, be sure to check the powers of the controller and brake release unit are OFF. Otherwise, it leads to the electrical shock or breakdown.
--	--

 CAUTION	<ul style="list-style-type: none"> ■ Release a brake for each joint one by one. If you need to release some brakes at a time, take a great care. Because when some joints are released at a time, the arms may fall to unintended directions. This is extremely dangerous and may break the manipulator or catch your hand, fingers. ■ Take care of the arm downward motion when the brake is released. While you are pressing the brake release switch, the arm moves downward by its own weight. This is extremely dangerous and may break the manipulator or catch your hand, fingers.
--	---

Width	180 mm
Depth	150 mm
Height	87 mm
Weight (Cables are not included.)	1.7 kg
Cable to the Manipulator	2 m
Power cable length	2 m
Power cable (US)	100 V specification
Power cable (EU)	200 V specification

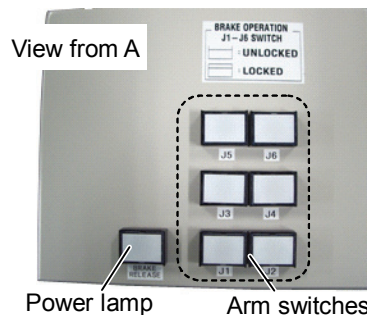
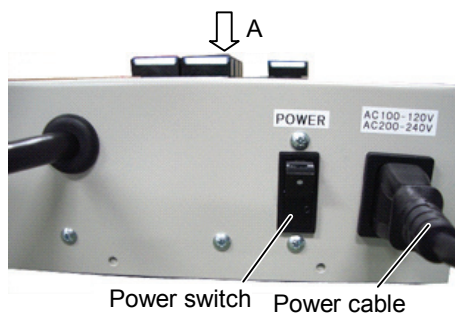

Precautions for use

 <p>CAUTION</p>	<ul style="list-style-type: none">■ After the brake release unit is disconnected, be sure to connect the external short connector. Otherwise, you cannot release the brakes.■ Keep the external short connector. Otherwise you cannot release the brakes.■ If you turn ON the brake release unit while the brake release switch is being pressed, an unintended arm may move downward. Before turning ON the brake release unit, make sure that the brake release switch is not pressed.■ If you turn ON the brake release unit without the connector, it may lead to the short for the male pin used in the connector. Before turning ON the brake release unit, make sure that the connector is connected.
--	---

NOTE

- When you purchased several C3 series manipulators and use the brake release unit in the manipulator without the connection cable, you need to change the connection cable inside the manipulator. To skip this switching work, purchase the cable set for the brake release unit. If you purchased the manipulator and connection cable together, the cable has been installed to the manipulator before shipment. For additional external short connector or connection cable, please contact us.

How to connect the connection cable

If you purchased the manipulator and connection cable together, the cable has been installed to the manipulator before shipment. This procedure is not necessary.

- (1) Turn OFF the controller.

- (2) Remove the hiding plate.

2-M4×8

- (3) Open the connector plate.

4-M4×8

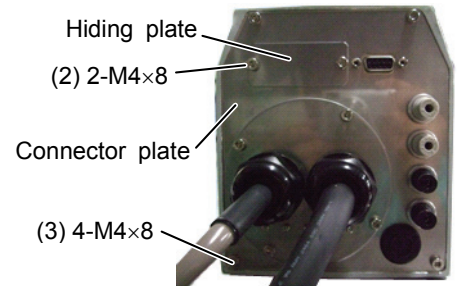

For details, refer to *Maintenance: 3. Covers.*

- (4) Pass the cable through the hole below the hiding plate from the outside.

Connect the connection cable to the connector plate.

2-M4×8

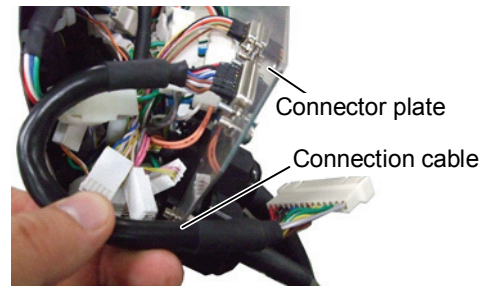

- (5) Take out the connector of internal cable SW1.

- (6) Disconnect the internal short connector.

Keep the short connector to the inside of base or somewhere not to lose.

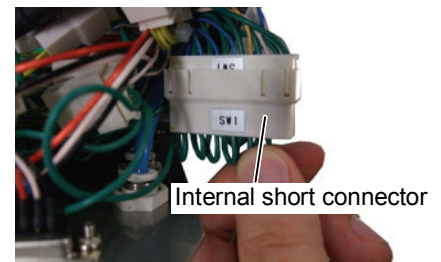

- (7) Connect the connection cable and internal cable SW1.

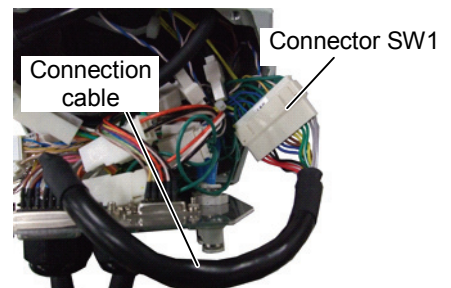

- (8) Mount the connector plate. Be careful not to catch the cables.

4-M4×8

- (9) If the brake release unit is not used, mount the external short connector.

To prevent the external short connector from falling off, secure the two screws included with the connector.

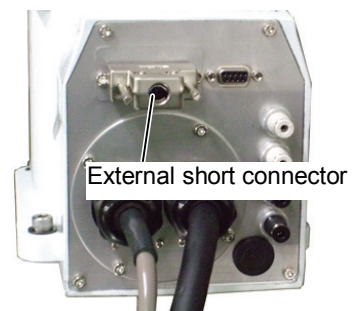

Mount the brake release unit

- (1) Turn OFF the controller.
- (2) Remove the external short connector.

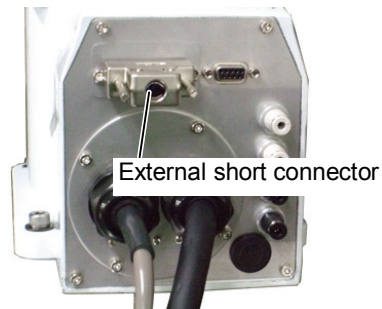

- (3) Connect the brake release unit to the connector of the connection cable.

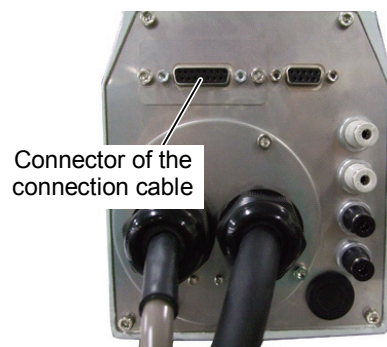

Remove the brake release unit

- (1) Turn OFF the brake release unit.
- (2) Remove the power cable of the brake release unit.
- (3) Disconnect the brake release unit from the connector of connection cable.
- (4) Connect the external short connector to the connector of connection cable.

How to use the brake release unit

 CAUTION	<ul style="list-style-type: none"> ■ Be careful of the arm downward motion while you release the brakes. The arm will move downward by its own weight while you are pressing a brake release switch. This is extremely dangerous and may break the manipulator or catch your hand, fingers. ■ If the arm you released the brake moves strange or slower than normal, stop the motion promptly and contact us. The brake release unit is possibly broken and if you keep operating the manipulator, it may lead to the brake of the manipulator or you will be caught by the hand or fingers.
---	--

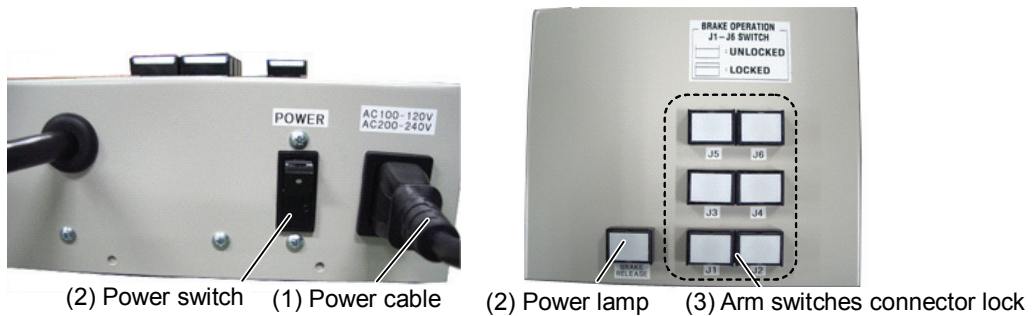

- (1) Disconnect the external short connector.
- (2) Plug the power cable into the brake release unit.
- (3) Plug the power cable into the power supply plug.
- (4) Turn ON the brake release unit.
When the brake release unit is enabled, the power lamp lights up.
- (5) Press the arm switch J1 ~ J6 you want to move and then move the arm.
Press the switch again, then the brake will be released.
The brake will be enabled by pressing the switch once again.



Move the arm the brake is released by two persons or more (one presses the switch and one moves the arm). The arm can be very heavy and needs the significant force to move.

6.2 Camera Plate Unit

To mount a camera to the C3 series manipulator, you need to mount the camera plate unit first.

Appearance of arm end with camera

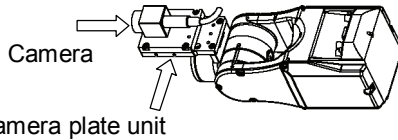

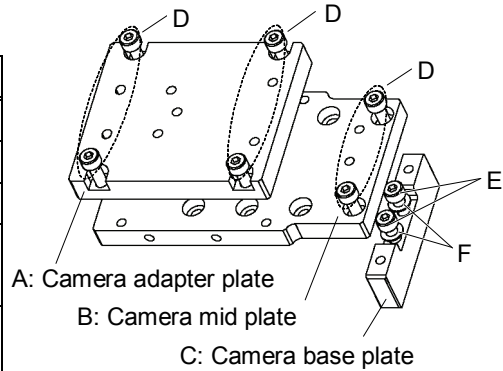

Parts included		unit
A	Camera adapter plate	1
B	Camera mid plate	1
C	Camera base plate	1
D	Hexagon socket head screws M4×12	6
E	hexagon socket head screws M4×20	2
F	Plain washer for M4 (small washer)	2

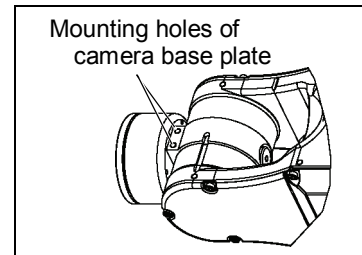

To mount the camera plate unit

- (1) Mount the camera base plate to the manipulator.
2-M4 × 20 + Plain washer for M4 (small washer)
- (2) Mount the camera mid plate to the base plate.
2-M4 × 12



NOTE  The motion range and dimension of the manipulator with the camera installed may vary depending on the mounting hole of camera mid plate. The details are described in the table below.

- (3) Mount the camera to the camera adapter plate.

NOTE  According to the camera, the available mounting hole of adapter plate will be different. The details are described below.

- (4) Mount the camera adapter plate and camera to the camera mid plate.
4-M4 × 12
- (5) Secure the cables at the position where they will not interfere with the manipulator motion.

NOTE  When securing the cables, check if the cables bend radius is big enough and the cables are not rubbing against each other while the manipulator moves. Otherwise, the cables will be disconnected.

Dimension of the camera plate unit

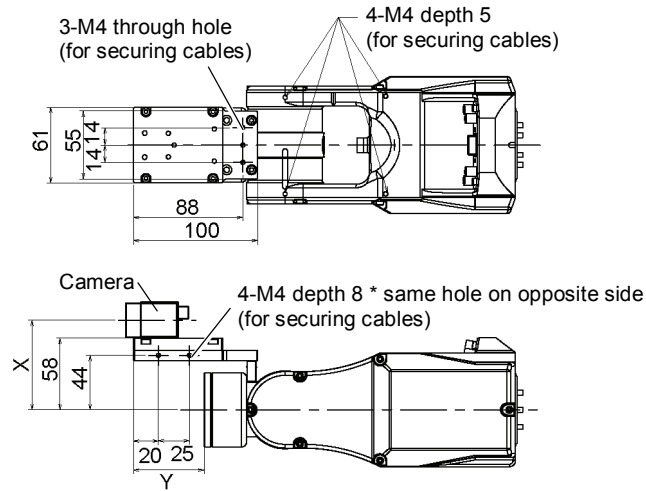

Dimensions X and Y will change depending on the position of camera mid plate and camera size. Refer to the table below for the values.

Camera mid plate

The camera mid plate uses the mounting holes A ~ D.

By using the different mounting holes, it can be mounted to the camera base plate in the different four positions.

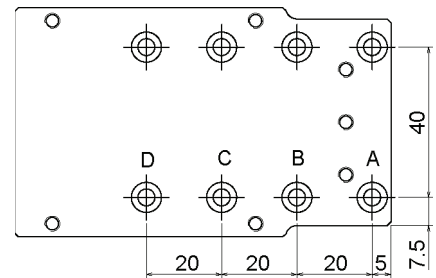

Camera adapter plate

Each camera uses the different mounting holes.

Sony XC-ES30, HR50, HR70 : 1, 2, 4

Matrox Iris : 1, 2, 3, 5

JAI (Pulnix) CV-A1 : 6, 7

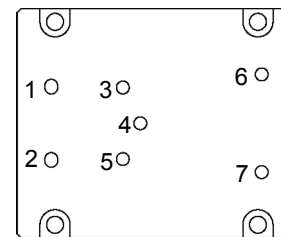

Mounting example

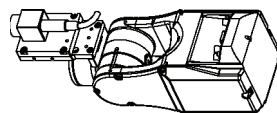

Using the mounting hole A

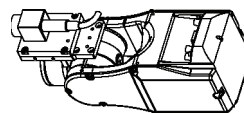

Using the mounting hole C

E.g.) Camera: XC-ES30

Camera vs. Joint #5 motion range (reference values)

The Joint #5 motion range varies depending on the mounting position of camera mid plate and the camera you are using.

The table below shows the motion range (reference values) based on the available cameras for this option and the mounting positions of the camera mid plate. The values in the table may vary depending on how to secure the cables.

By changing the Y position, you can extend the distance from the end effector mounting surface to the camera. Also, you can attach the larger end effector. However, be careful about the Joint #5 motion range that will be limited in this case.

(° = degree)

	A	B	C	D	X
JAI (Pulnix) CV-A1	-135° ~ +60°	-135° ~ +50°	-135° ~ +35°	-135° ~ +25°	72.5 mm
Sony XC-ES30, HR50, HR70					
Matrox Iris	-135° ~ +45°	-135° ~ +30°	-135° ~ +15°	-135° ~ +10°	83 mm

	A	B	C	D
Y	57 mm	37 mm	17 mm	7 mm

Direction of the Joint #5 motion

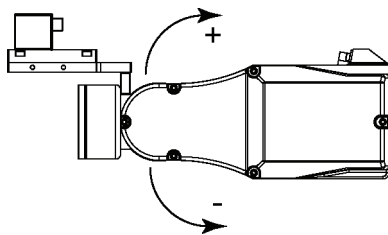

6.3 PS Compatible Plate

Using the PS compatible plate, you can mount the end effector used in the PS series to the C3 series.

Parts included		Unit
A	PS compatible plate	1
B	Dowel pin (M3 hole on one side)	1
C	Hexagon socket head screw M4×12	4

Dimensions of PS-compatible plate

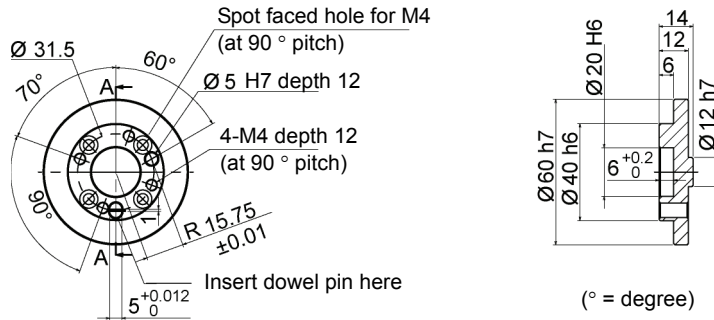

C: Hexagon socket head screw
4-M4×12

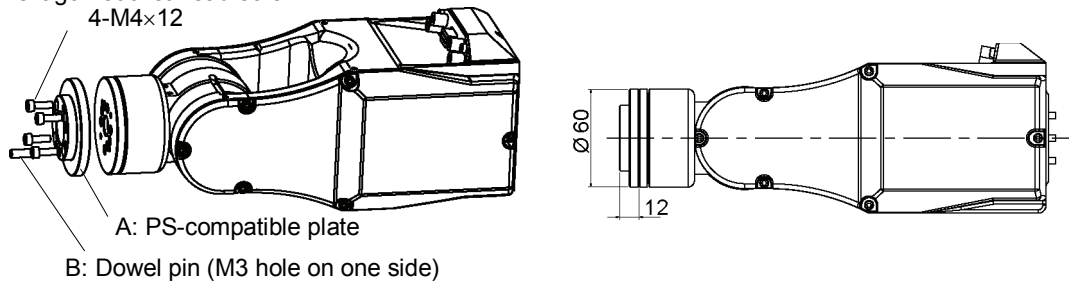

To mount the PS compatible plate

- (1) Align the hole on the arm end flange ($\varnothing 12H7$) to the projection on the PS compatible plate ($\varnothing 12h7$).
- (2) Insert the dowel pin from the PS compatible plate side and position the arm and PS compatible plate. One side of the dowel pin has the M3 screw hole and you can adjust the depth using M3.



NOTE If you move the manipulator with the dowel pin inserted, the dowel pin will fall out. Even so you want to move the manipulator, you need to secure the dowel pin with glue.

- (3) Secure the PS compatible plate with 4 hexagon socket head screws.

4-M4 × 12

6.4 Base Side Angled Fittings

Using the base side angled fittings to the C3 series manipulator base, you can mount the manipulator in skewed position. The motion range expands with this mounting type more than the normal ceiling mounting.

Mounting image using the base side angled fittings

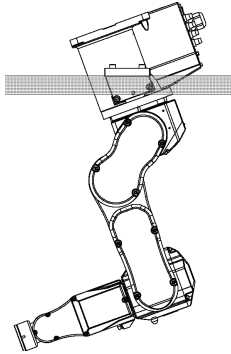

For details of the mounting and precautions, refer to *Setup & Operation: 3. Environment and Installation*.

Parts included		Unit
A	Base side angled plate (Left side)	1
B	Base side angled plate (Right side)	1
C	Base side plate (for Skewed mounting type)	2
D	Pin	6
E	Hexagon socket head screw M8 × 25	4
F	Hexagon socket head screw M8 × 30	4

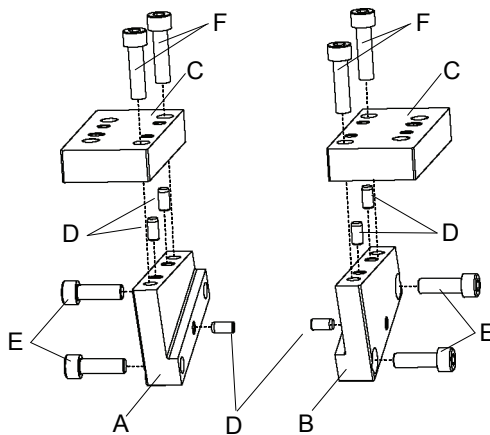

To mount the base side angled fittings

- (1) Drive pins to the base side plate (for Skewed mounting type).

Protruding part of pins is approx. 2 ~ 5 mm.



Two pins
Protruding part
2mm~5mm

- (2) Drive pins to the base side angled plate (left & right sides).

Protruding part of pins is approx. 2 ~ 5 mm.

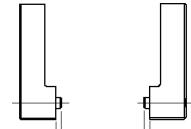

Pin at each side
Protruding part
2mm~5mm

- (3) Create a base side angled fittings.

Fit the pins of the plate for Skewed mounting type in the step (1) with the holes on the plate in the step (2) and secure with the screws.

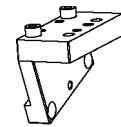

Right side

Hexagon socket head screw M8 × 30

- (4) Mount the base side angled fittings to the both sides of manipulator base.

Fit the pins drove in the step (2) with the holes on the base. Secure the fittings by pressing it to the indicated direction in the figure below.

Left & Right side Hexagon socket heat screw 2- M8 × 25

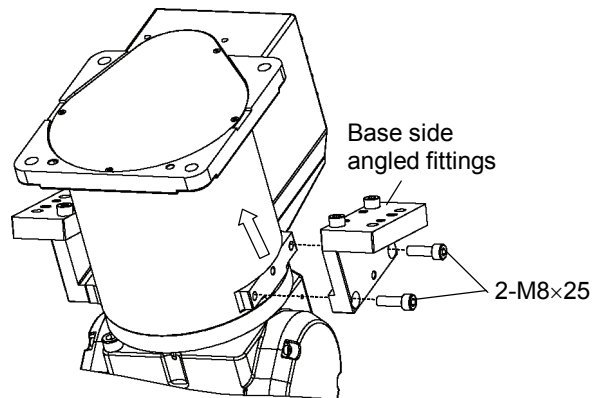

NOTE The shape of base side angled fittings is different for left and for right. Be sure to mount the correct fittings. Otherwise, the motion range of Arm #2 is limited in the backside.

6.5 Base Side Fittings

Using the base side fittings to the C3 manipulator base, you can mount the manipulator in the place where limits the mounting height or use the open room for the base.

Mounting image using the base side fittings

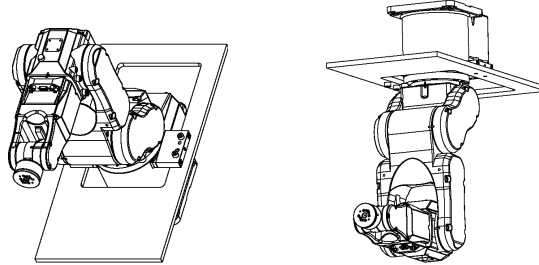

For the information on how to mount and precautions, refer to *Setup & Operation: 3. Environment and Installation*.

Parts included		Unit
A	Base side plate	2
B	Pin	2
C	Hexagon socket head screw M8 × 60	4

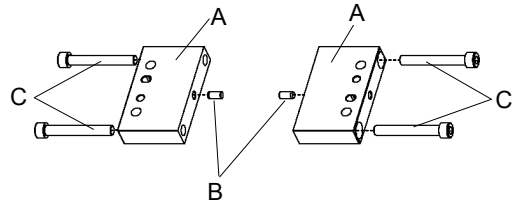

To mount the base side plate

- (1) Drive the pins to the base side plate.

Protruding part of pins is approx. 2 ~ 5 mm.

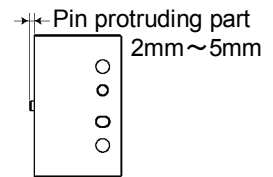

- (2) Mount the base side plate with the pins driven to the both sides of the base.

Fit the pins with the holes and secure the base side plate by pressing it from above to the base fixing part.

(With the steps above, the both surfaces of base side fittings can be stable.)

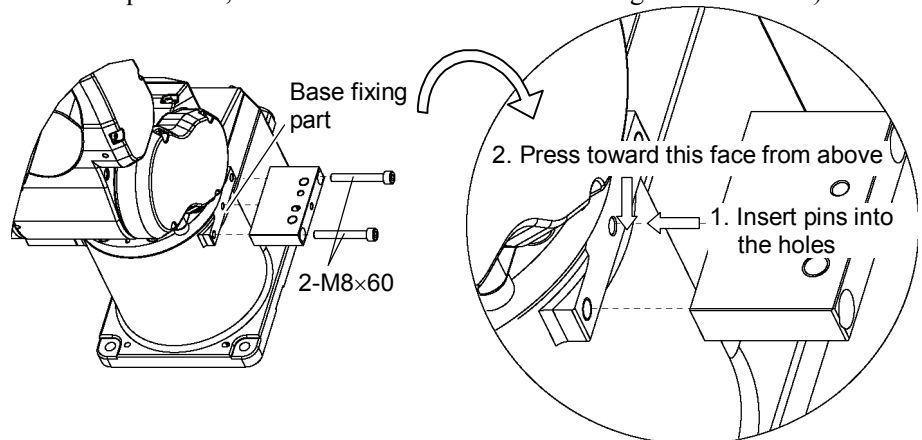

Mounting example

Available screws

	Size	Recommended length
A	M8	30 mm or more
B	M10	15 mm + Base Plate or more

NOTE  The base side plate has a M10 screw hole. You can secure with a M10 screw or M8 screw by using a M10 prepared screw of $\varnothing 8.5$ to make a M8 screw hole on the mounting surface.

A: Securing from above

To secure from above, use the screw A in the table above.

When you install the manipulator for practical use, you need to insert the screws in the right/left side from the same direction (above or below).

Table Top mounting

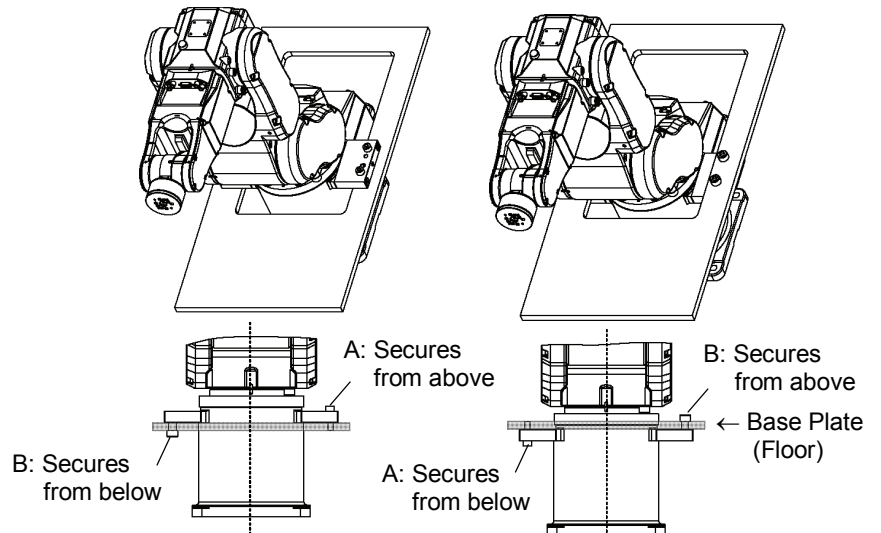

Ceiling mounting

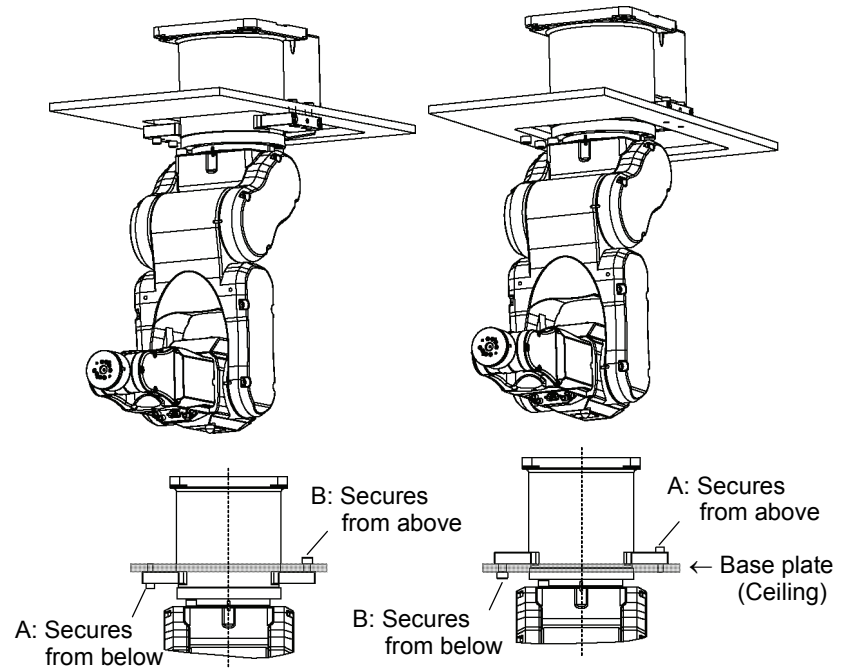

Maintenance

This volume contains maintenance procedures with safety precautions for C3 series Manipulators.

1. Safety Maintenance

Please read this chapter, this manual, and other relevant manuals carefully to understand safe maintenance procedures before performing any routine maintenance.

Only authorized personnel who have taken safety training should be allowed to maintain the robot system.

Safety training is the program for industrial robot operators that follows the laws and regulations of each nation.

The personnel who have taken safety training acquire knowledge of industrial robots (operations, teaching, etc.), knowledge of inspections, and knowledge of related rules/regulations.

The personnel who have completed the robot system-training and maintenance-training classes held by the manufacturer, dealer, or locally-incorporated company are allowed to maintain the robot system.



- Do not remove any parts that are not covered in this manual. Follow the maintenance procedure strictly as described in this manual. Improper removal of parts or improper maintenance may not only cause improper function of the robot system but also serious safety problems.
- Keep away from the Manipulator while the power is ON if you have not taken the training courses. Do not enter the operating area while the power is ON. Entering the operating area with the power ON is extremely hazardous and may cause serious safety problems as the Manipulator may move even it seems to be stopped.
- When you check the operation of the Manipulator after replacing parts, be sure to check it while you are outside of the safeguarded area. Checking the operation of the Manipulator while you are inside of the safeguarded area may cause serious safety problems as the Manipulator may move unexpectedly.
- Before operating the robot system, make sure that both the Emergency Stop switches and safeguard switch function properly. Operating the robot system when the switches do not function properly is extremely hazardous and may result in serious bodily injury and/or serious damage to the robot system as the switches cannot fulfill their intended functions in an emergency.



- To shut off power to the robot system, pull out the power plug from the power source. Be sure to connect the AC power cable to a power receptacle. DO NOT connect it directly to a factory power source.
- Before performing any replacement procedure, turn OFF the Controller and related equipment, and then pull out the power plug from the power source. Performing any replacement procedure with the power ON is extremely hazardous and may result in electric shock and/or malfunction of the robot system.

 CAUTION	<ul style="list-style-type: none"> Be sure to connect the cables properly. Do not allow unnecessary strain on the cables. (Do not put heavy objects on the cables. Do not bend or pull the cables forcibly.) The unnecessary strain on the cables may result in damage to the cables, disconnection, and/or contact failure. Damaged cables, disconnection, or contact failure is extremely hazardous and may result in electric shock and/or improper function of the robot system.
--	---

2. General Maintenance

This chapter describes maintenance inspections and procedures. Performing maintenance inspections and procedures properly is essential for preventing trouble and ensuring safety. Be sure to perform the maintenance inspections in accordance with the schedule.

2.1 Schedule for Maintenance Inspection

Inspection points are divided into five stages: daily, monthly, quarterly, biannual, and annual. The inspection points are added every stage.

If the Manipulator is operated for 250 hours or longer per month, the inspection points must be added every 250 hours, 750 hours, 1500 hours, and 3000 hours operation.

	Inspection Point				
	Daily inspection	Monthly inspection	Quarterly inspection	Biannual inspection	Annual inspection
1 month (250 h)	Inspect every day	√			
2 months (500 h)		√			
3 months (750 h)		√	√		
4 months (1000 h)		√			
5 months (1250 h)		√			
6 months (1500 h)		√	√	√	
7 months (1750 h)		√			
8 months (2000 h)		√			
9 months (2250 h)		√	√		
10 months (2500 h)		√			
11 months (2750 h)		√			
12 months (3000 h)		√	√	√	√
13 months (3250 h) ⋮		⋮	√ ⋮	⋮	⋮

h = hour

2.2 Inspection Point

2.2.1 Inspection While the Power is OFF (Manipulator is not operating)

Inspection Point	Inspection Place	Daily	Monthly	Quarterly	Biannual	Annual
Check looseness or backlash of bolts/screws. Tighten them if necessary. (For the tightening torque, refer to <i>Maintenance: 2.4 Tightening Hexagon Socket Head Cap Bolts.</i>)	End effector mounting bolts	√	√	√	√	√
	Manipulator mounting bolts	√	√	√	√	√
	Each arm locking bolts	√	√	√	√	√
	Bolts/screws around shaft					√
	Bolts/screws securing motors, reduction gear units, etc.					√
Check looseness of connectors. If the connectors are loosen, push it securely or tighten.	External connectors on Manipulator (on the connector plates etc.)	√	√	√	√	√
	Manipulator cable unit		√	√	√	√
Visually check for external defects. Clean up if necessary.	External appearance of Manipulator	√	√	√	√	√
	External cables		√	√	√	√
Check for bends or improper location. Repair or place it properly if necessary.	Safeguard etc.	√	√	√	√	√
Check tension of timing belts. Tighten it if necessary.	Base Inside of Arms #1, 2, 3, 4				√	√
Grease conditions	Refer to <i>Maintenance: 2.3 Greasing.</i>					

2.2.2 Inspection While the Power is ON (Manipulator is operating)

Inspection Point	Inspection Place	Daily	Monthly	Quarterly	Biannual	Annual
Check motion range	Each joint					√
Move the cables back and forth lightly to check whether the cables are disconnected.	External cables (including cable unit of the Manipulator)				√	√
Push each arm in MOTOR ON status to check whether backlash exists.	Each arm					√
Check whether unusual sound or vibration occurs.	Whole	√	√	√	√	√
Measure the accuracy repeatedly by a dial gauge.	Whole					√

2.3 Greasing

The reduction gear units and bevel gear need greasing regularly. Only use the grease specified in the following table.

 CAUTION	<ul style="list-style-type: none"> ■ Keep enough grease in the Manipulator. Operating the Manipulator with insufficient grease will cause the noise or damage sliding parts and/or result in insufficient function of the Manipulator. Once the parts are damaged, a lot of time and money will be required for the repairs. ■ If grease gets into your eyes, mouth, or on your skin, follow the instructions below. <ul style="list-style-type: none"> If grease gets into your eyes : Flush them thoroughly with clean water, and then see a doctor immediately. If grease gets into your mouth : If swallowed, do not induce vomiting. See a doctor immediately. : If grease just gets into your mouth, wash out your mouth with water thoroughly. If grease gets on your skin : Wash the area thoroughly with soap and water.
--	---

	Greasing part	Greasing Interval	Grease	Greasing method
Joint #1, 2, 3, 4	Reduction gear units	In the replacement of motor*	SK-1A	Please contact us.
Joint #6	Bevel gear	Once a year (every 8000 hours)	SK-2	Follow the steps below.

* Under normal conditions, the reduction gear units shall be greased only when the motor is replaced. However, in case of severe working conditions (such as high duty, high speeds, large payloads, etc.), the reduction gear units must be greased every 10,000 hours.

Greasing Joint #6 bevel gear

Maintenance Parts and Tools

	Name	Quantity	Note
Maintenance Parts	Grease for reduction gear unit (SK-2)	Proper quantity	
Tools	Screw M4×15 (length: 15 mm or more)	1	For unplugging
	Wiping cloth	1	For wiping grease

- (1) Secure Arm #5 in the direction you can unplug easily.
- (2) Insert the screw into the screw part of plug. M4 depth 5.
Screw : M4 length 15 mm or more (easy-to-unplug)
- (3) Hold the screw inserted in the step (2) and unplug.
- (4) Apply the grease.
Grease amount : 2 g
- (5) Insert the plug unplugged in the step (3) to the original position.
To prevent the grease leaking or unplugging, be sure to insert the plug all the way seated.
- (6) Pull out the screw inserted in the step (2).

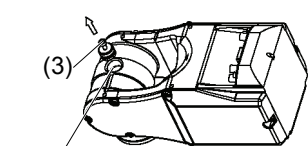
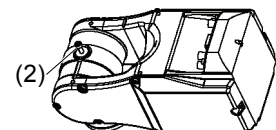
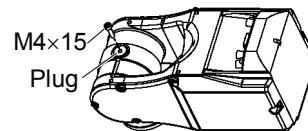

(4) Apply grease here

2.4 Tightening Hexagon Socket Head Cap Bolts

Hexagon socket head cap bolts are used in places where mechanical strength is required. (A hexagon socket head cap bolt will be called a “bolt” in this manual.) These bolts are fastened with the tightening torques shown in the following table.

When it is necessary to refasten these bolts in some procedures in this manual (except special cases as noted), use a torque wrench so that the bolts are fastened with the appropriate tightening torques as shown below.

Bolt	Tightening Torque
M3	2.5 N·m (25 kgf·cm)
M4	4.9 N·m (50 kgf·cm)
M5	9.8 N·m (100 kgf·cm)
M6	17.6 N·m (180 kgf·cm)
M8	37.2 N·m (380 kgf·cm)
M10	73.5 N·m (750 kgf·cm)
M12	127.4 N·m (1,300 kgf·cm)

Refer below for the set screw.

Set Screw	Tightening Torque
M4	2.5 N·m (25 kgf·cm)
M5	3.9 N·m (40 kgf·cm)

We recommend that the bolts aligned on a circumference should be fastened in a crisscross pattern as shown in the figure below.

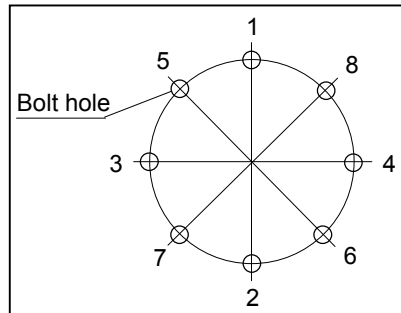

Do not fasten all bolts securely at one time. Divide the number of times that the bolts are fastened into two or three and fasten the bolts securely with a hexagonal wrench. Then, use a torque wrench so that the bolts are fastened with tightening torques shown in the table above.

2.5 Layout of Maintenance Parts

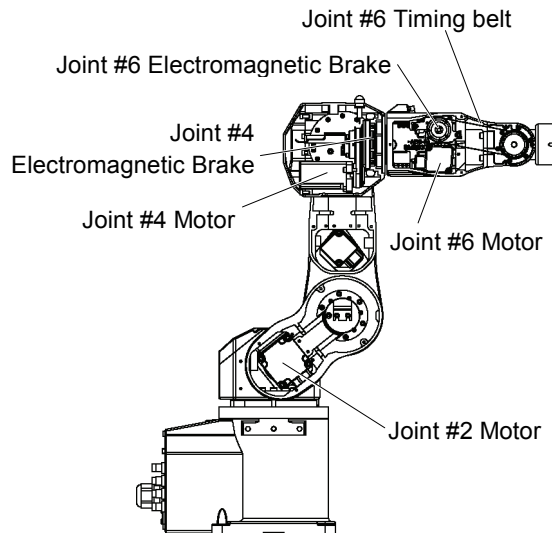
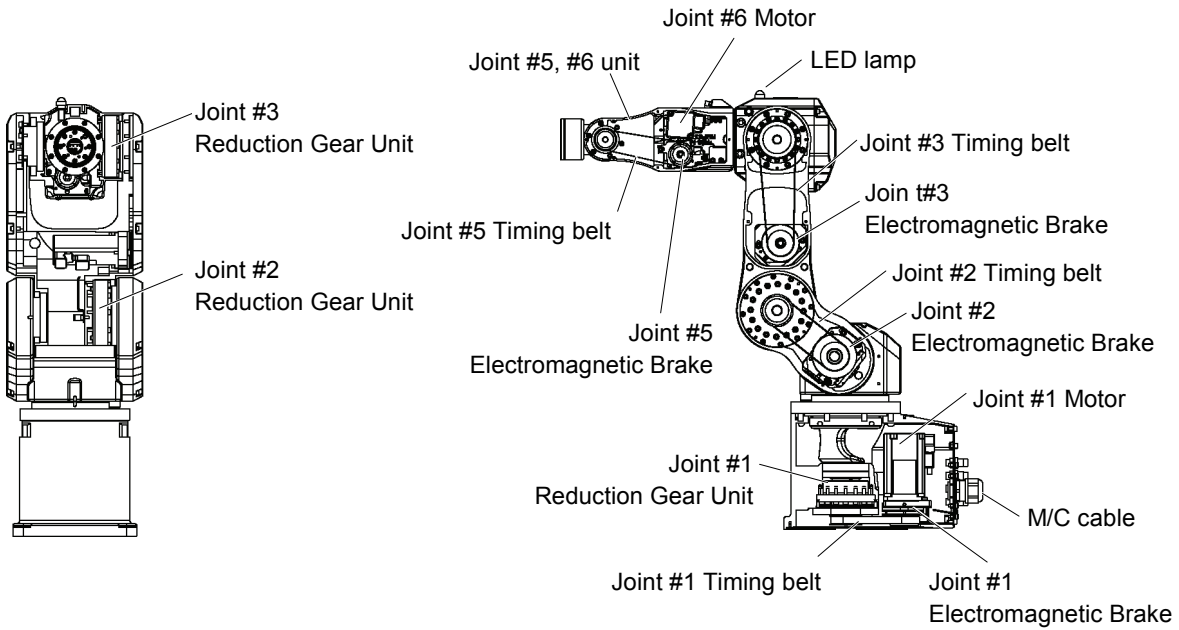
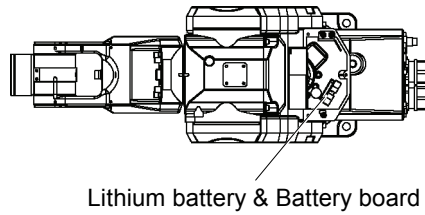

3. Covers

All procedures for removing and installing covers in maintenance are described in this chapter.

 WARNING	<ul style="list-style-type: none"> ■ Do not insert or pull out the motor connectors while the power to the robot system is turned ON. Inserting or pulling out the motor connectors with the power ON is extremely hazardous and may result in serious bodily injury as the Manipulator may move abnormally, and also may result in electric shock and/or malfunction of the robot system. ■ To shut off power to the robot system, pull out the power plug from the power source. Be sure to connect the AC power cable to a power receptacle. DO NOT connect it directly to a factory power source. ■ Before performing any replacement procedure, turn OFF the Controller and related equipment, and then pull out the power plug from the power source. Performing any replacement procedure with the power ON is extremely hazardous and may result in electric shock and/or malfunction of the robot system. ■ Be careful not to get any foreign substances in the Manipulator, connectors, and pins during maintenance. Turning ON the power to the robot system when any foreign substances exist in them is extremely hazardous and may result in electric shock and/or malfunction of the robot system.
---	---

Tools

	Name	Quantity	Note
Tools	Hexagonal wrench (width across flats: 2.5 mm)	1	For M3 screw
	Hexagonal wrench (width across flats: 3 mm)	1	For M4 screw
	Cross-point screwdriver	1	

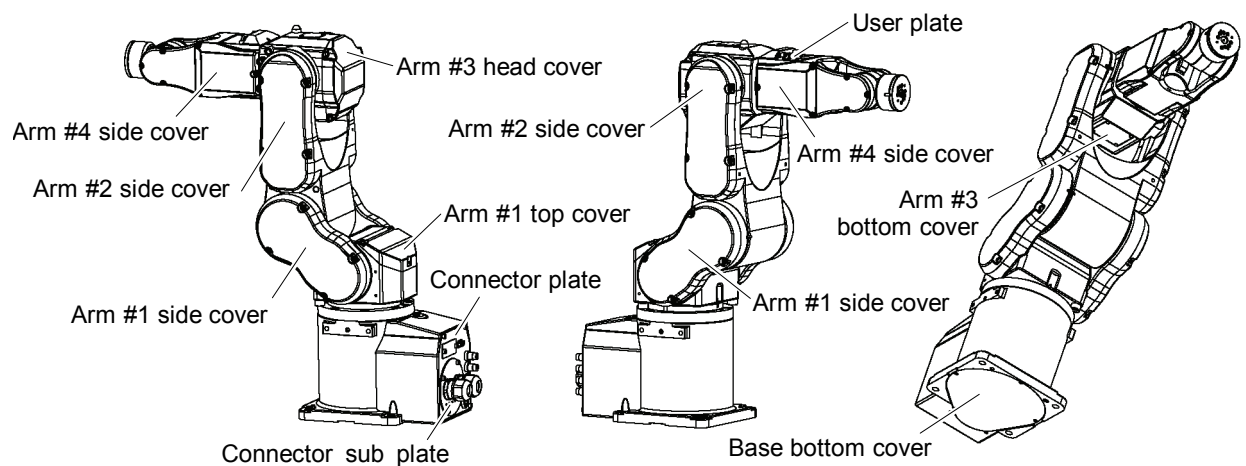

3.1 Arm #1 Top Cover



CAUTION

- When installing the cover, be careful not to allow the cables to interfere with the cover mounting and do not bend these cables forcibly to push them into the cover. Unnecessary strain on cables may result in damage to the cables, disconnection, and/or contact failure. Damaged cables, disconnection, or contact failure is extremely hazardous and may result in electric shock and/or improper function of the robot system. When routing the cables, observe the cable locations after removing the cover. Be sure to place the cables back to their original locations.

Unscrew the cover mounting bolts and remove the cover.

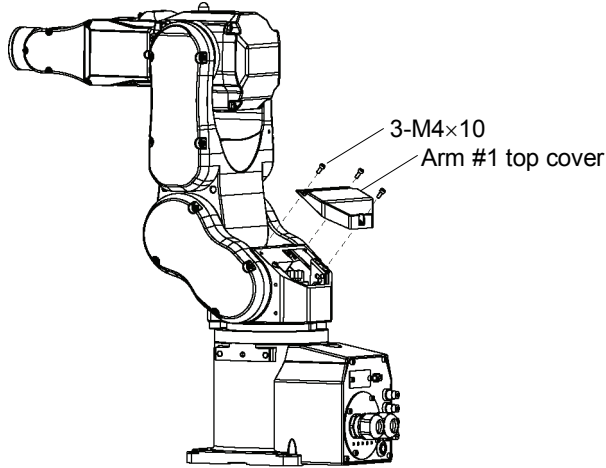

3.2 Arm #1 Side Cover



CAUTION

- When installing the cover, be careful not to allow the cables to interfere with the cover mounting and do not bend these cables forcibly to push them into the cover. Unnecessary strain on cables may result in damage to the cables, disconnection, and/or contact failure. Damaged cables, disconnection, or contact failure is extremely hazardous and may result in electric shock and/or improper function of the robot system. When routing the cables, observe the cable locations after removing the cover. Be sure to place the cables back to their original locations.

Unscrew the cover mounting bolts and remove the cover.

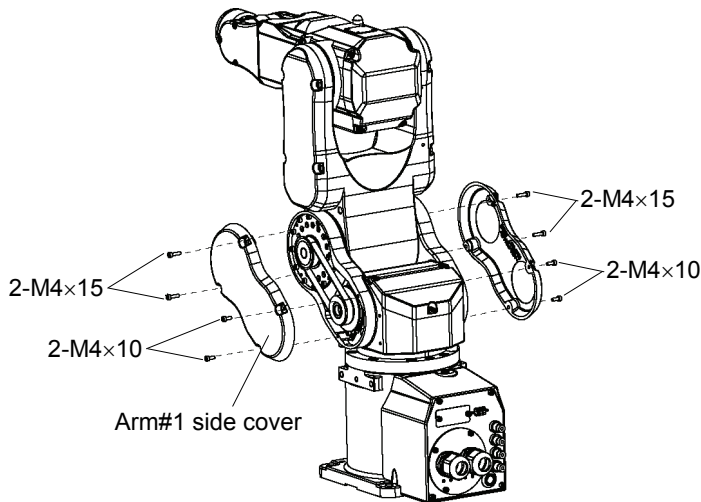

3.3 Arm#2 Side Cover



CAUTION

- When installing the cover, be careful not to allow the cables to interfere with the cover mounting and do not bend these cables forcibly to push them into the cover. Unnecessary strain on cables may result in damage to the cables, disconnection, and/or contact failure. Damaged cables, disconnection, or contact failure is extremely hazardous and may result in electric shock and/or improper function of the robot system. When routing the cables, observe the cable locations after removing the cover. Be sure to place the cables back to their original locations.

Unscrew the cover mounting bolts and remove the cover.

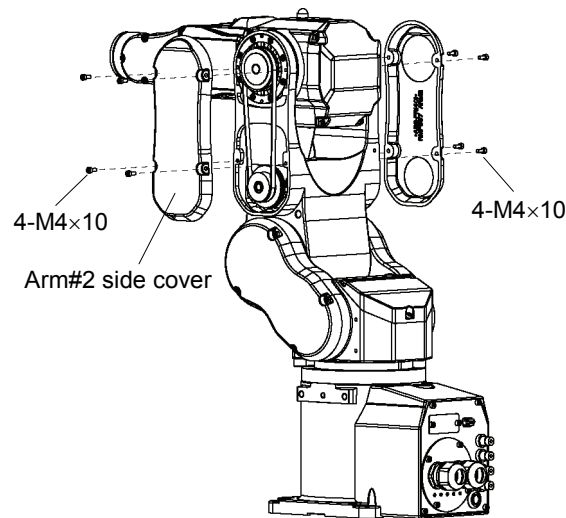

3.4 Arm#3 Head Cover



CAUTION

- When installing the cover, be careful not to allow the cables to interfere with the cover mounting and do not bend these cables forcibly to push them into the cover. Unnecessary strain on cables may result in damage to the cables, disconnection, and/or contact failure. Damaged cables, disconnection, or contact failure is extremely hazardous and may result in electric shock and/or improper function of the robot system. When routing the cables, observe the cable locations after removing the cover. Be sure to place the cables back to their original locations.

Unscrew the cover mounting bolts and remove the cover.

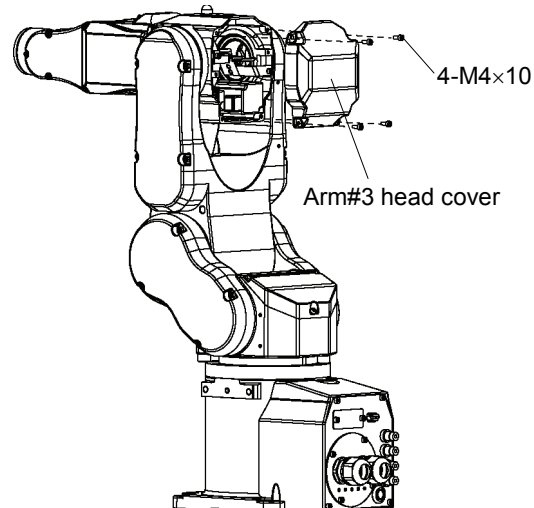

3.5 Arm #3 Bottom Cover



CAUTION

- When installing the cover, be careful not to allow the cables to interfere with the cover mounting and do not bend these cables forcibly to push them into the cover. Unnecessary strain on cables may result in damage to the cables, disconnection, and/or contact failure. Damaged cables, disconnection, or contact failure is extremely hazardous and may result in electric shock and/or improper function of the robot system. When routing the cables, observe the cable locations after removing the cover. Be sure to place the cables back to their original locations.

Move the arm so that you can remove the Arm #3 bottom cover.

Remove the screws (cross-recessed head truss screws) securing the cover and remove the cover.

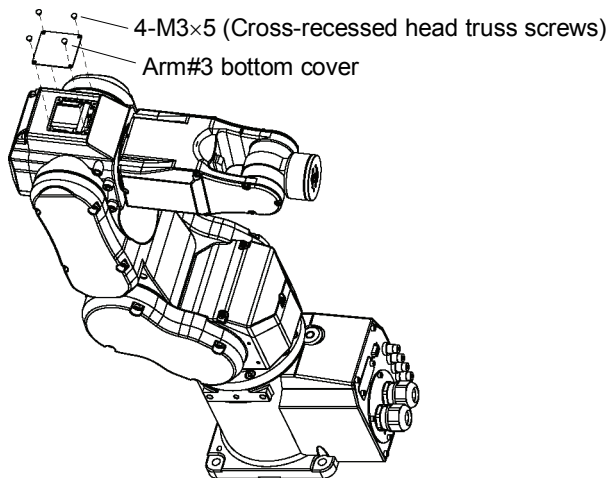

3.6 Arm#4 side cover

 CAUTION	<ul style="list-style-type: none"> When installing the cover, be careful not to allow the cables to interfere with the cover mounting and do not bend these cables forcibly to push them into the cover. Unnecessary strain on cables may result in damage to the cables, disconnection, and/or contact failure. Damaged cables, disconnection, or contact failure is extremely hazardous and may result in electric shock and/or improper function of the robot system. When routing the cables, observe the cable locations after removing the cover. Be sure to place the cables back to their original locations.
---	---

Unscrew the cover mounting bolts and remove the cover.

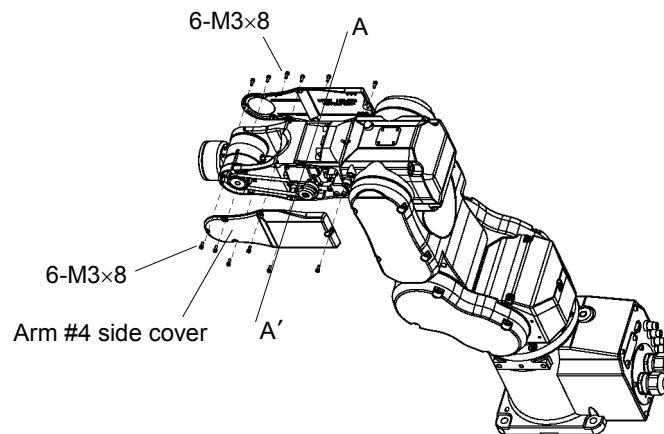

NOTE

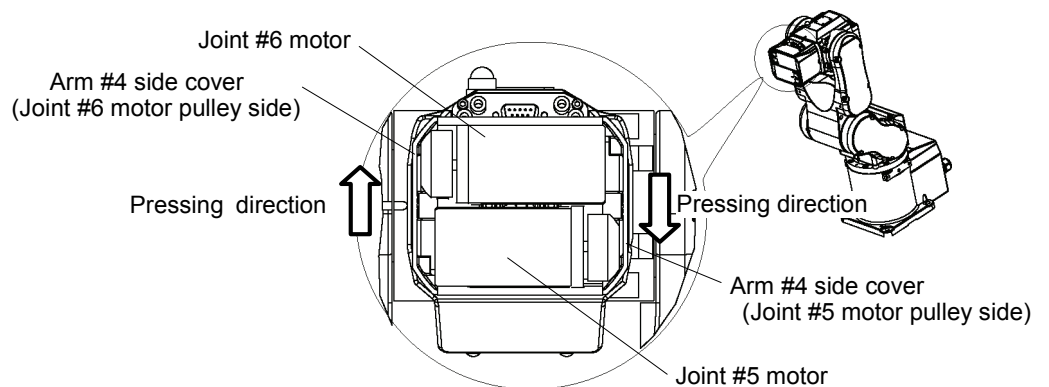

To improve the manipulator performance, clearances of the Arm #4 side cover, Joint #5 motor pulley, and Joint #6 motor pulley have become smaller.

To avoid the interference of covers and pulleys, attach the Arm #4 side cover.



A - A' Cross section detail

3.7 Base Bottom Cover

 CAUTION	<ul style="list-style-type: none"> When installing the cover, be careful not to allow the cables to interfere with the cover mounting and do not bend these cables forcibly to push them into the cover. Unnecessary strain on cables may result in damage to the cables, disconnection, and/or contact failure. Damaged cables, disconnection, or contact failure is extremely hazardous and may result in electric shock and/or improper function of the robot system. When routing the cables, observe the cable locations after removing the cover. Be sure to place the cables back to their original locations.
--	--

Remove the screws (cross-recessed flat head machine screws) securing the cover and remove the cover.

If you use the other screws than the screws indicated here, the screw head will protrude from the base surface and it will make it difficult to mount the manipulator firmly. We recommend using our attached screws or equivalent ones.

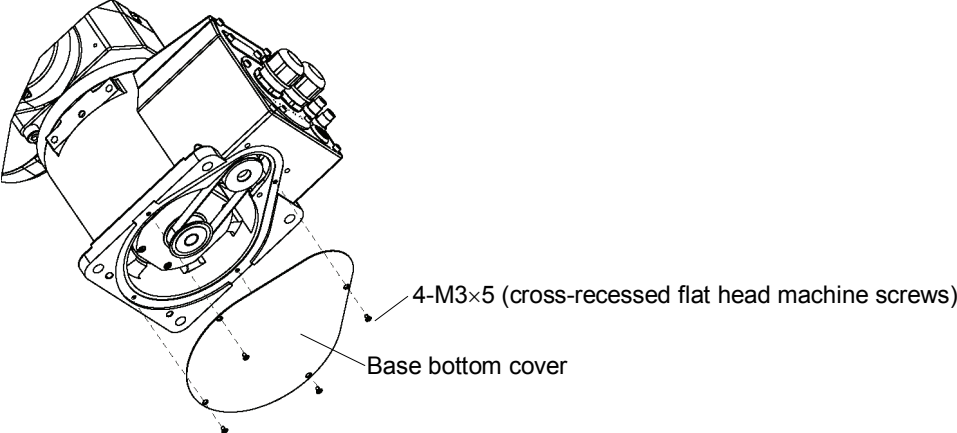

3.8 Connector Plate

 CAUTION	<ul style="list-style-type: none"> Do not remove the connector plate forcibly. Removing the connector plate forcibly may result in damage to the cables, disconnection, and/or contact failure. Damaged cables, disconnection, or contact failure is extremely hazardous and may result in electric shock and/or improper function of the robot system. When installing the connector plate, be careful not to allow the cables to interfere with the plate mounting and do not bend these cables forcibly to push them into the cover. Unnecessary strain on cables may result in damage to the cables, disconnection, and/or contact failure. Damaged cables, disconnection, or contact failure is extremely hazardous and may result in electric shock and/or improper function of the robot system. When routing the cables, observe the cable locations after removing the connector plate. Be sure to place the cables back to their original locations.
--	--

Unscrew the connector plate mounting bolts and remove the connector plate.

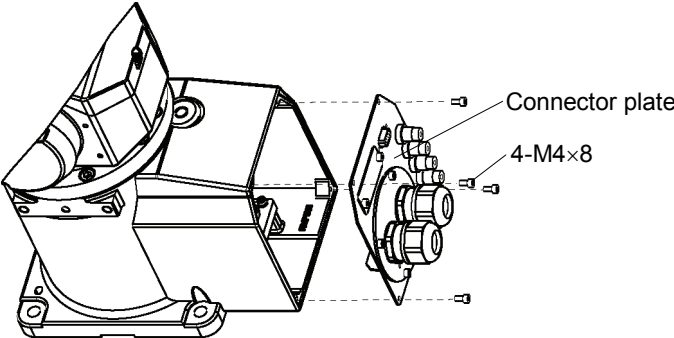

3.9 Connector Sub Plate

 CAUTION	<ul style="list-style-type: none"> ■ Do not remove the connector sub plate forcibly. Removing the connector sub plate forcibly may result in damage to the cables, disconnection, and/or contact failure. Damaged cables, disconnection, or contact failure is extremely hazardous and may result in electric shock and/or improper function of the robot system. ■ When installing the connector sub plate, be careful not to allow the cables to interfere with the plate mounting and do not bend these cables forcibly to push them into the cover. Unnecessary strain on cables may result in damage to the cables, disconnection, or contact failure. Damaged cables, disconnection, or contact failure is extremely hazardous and may result in electric shock and/or improper function of the robot system. When routing the cables, observe the cable locations after removing the connector sub plate. Be sure to place the cables back to their original locations.
---	--

Unscrew the connector sub plate mounting bolts and remove the connector sub plate.

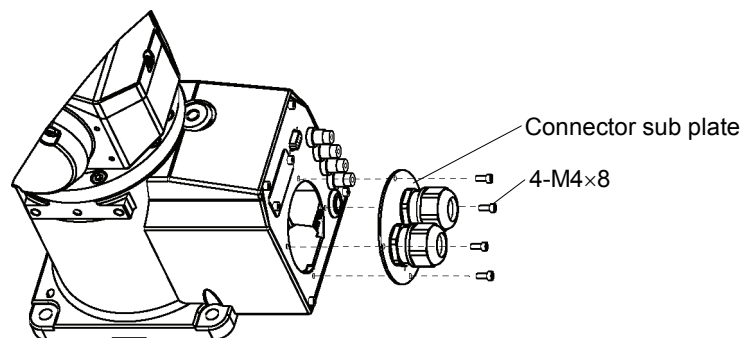

3.10 User Plate

 CAUTION	<ul style="list-style-type: none"> ■ When installing the cover, be careful not to allow the cables to interfere with the cover mounting and do not bend these cables forcibly to push them into the cover. Unnecessary strain on cables may result in damage to the cables, disconnection, and/or contact failure. Damaged cables, disconnection, or contact failure is extremely hazardous and may result in electric shock and/or improper function of the robot system. When routing the cables, observe the cable locations after removing the cover. Be sure to place the cables back to their original locations.
---	--

Unscrew the user plate mounting bolts and remove the user plate.

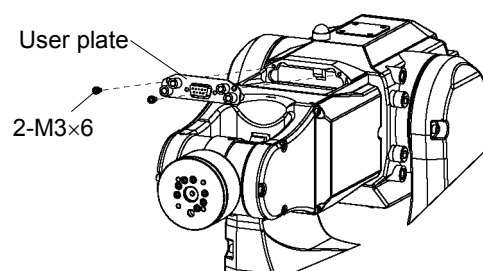

4. Cable Unit

4.1 Replacing the Cable Unit



- Before performing any replacement procedure, turn OFF the Controller and related equipment, and then pull out the power plug from the power source. Performing any replacement procedure with the power ON is extremely hazardous and may result in electric shock and/or malfunction of the robot system.
- Do not insert or pull out the motor connectors while the power to the robot system is turned ON. Inserting or pulling out the motor connectors with the power ON is extremely hazardous and may result in serious bodily injury as the Manipulator may move abnormally, and also may result in electric shock and/or malfunction of the robot system.
- Be sure to connect the AC power cable to a power receptacle. DO NOT connect it directly to a factory power source. To shut off power to the robot system, pull out the power plug from the power source. Performing any work while connecting the AC power cable to a factory power source is extremely hazardous and may result in electric shock and/or malfunction of the robot system.
- Be careful not to get any foreign substances in the Manipulator, connectors, and pins during maintenance. Turning ON the power to the robot system when any foreign substances exist in them is extremely hazardous and may result in electric shock and/or malfunction of the robot system.
- Be sure to connect the cables properly. Do not allow unnecessary strain on the cables. (Do not put heavy objects on the cables. Do not bend or pull the cables forcibly.) The unnecessary strain on the cables may result in damage to the cables, disconnection, and/or contact failure. Damaged cables, disconnection, or contact failure is extremely hazardous and may result in electric shock and/or improper function of the robot system.
- When installing the cover, be careful not to allow the cables to interfere with the cover mounting and do not bend these cables forcibly to push them into the cover. Unnecessary strain on cables may result in damage to the cables, disconnection, and/or contact failure. Damaged cables, disconnection, or contact failure is extremely hazardous and may result in electric shock and/or improper function of the robot system.
When routing the cables, observe the cable locations after removing the cover. Be sure to place the cables back to their original locations.

 CAUTION	<ul style="list-style-type: none"> ■ When disconnecting the connectors during the replacement of the cable unit, be sure to reconnect the connectors to their proper positions. Improper connection of the connectors may result in improper function of the robot system. For details on the connections, refer to the <i>Maintenance 10.3 Connector Pin Assignments</i>. ■ Carefully use alcohol and adhesive following respective instructions and also instructions below. Otherwise, it may cause a fire and/or safety problems. <ul style="list-style-type: none"> - Never put alcohol or adhesive close to fire. - Use alcohol or adhesive while ventilating the room. - Wear protective gear including a mask, protective goggles, and oil-resistant gloves. - If alcohol or adhesive gets on your skin, wash the area thoroughly with soap and water. - If alcohol or adhesive gets into your eyes or mouth, flush your eyes or wash out your mouth with clean water thoroughly, and then see a doctor immediately. ■ Wear protective gear including a mask, protective goggles, and oil-resistant gloves during grease up. If grease gets into your eyes, mouth, or on your skin, follow the instructions below. <ul style="list-style-type: none"> If grease gets into your eyes : Flush them thoroughly with clean water, and then see a doctor immediately. If grease gets into your mouth : If swallowed, do not induce vomiting. See a doctor immediately. If grease just gets into your mouth, wash out your mouth with water thoroughly. If grease gets on your skin : Wash the area thoroughly with soap and water.
---	--

Maintenance Parts, Tools, and Material

	Name	Quantity	Note
Maintenance Parts	Grease (Krytox)	Proper quantity	R13B030304
	Cable unit	1	R13B020036
Tools	Hexagonal wrench (width across flats: 2.5 mm)	1	For M3 screw
	Hexagonal wrench (width across flats: 3 mm)	1	For M4 screw
	Box wrench (width across flats: 5 mm)	1	For D-Sub connector
	Long nose pliers	1	For removing air connector
	Nippers	1	
	Cross-point screwdriver	1	
	Brush	1	For applying grease
	Force gauge	1	For belt tension
Material	Alcohol	Proper quantity	
	Wire tie (AB100)	18	
	Wire tie (AB150)	11	
	Wire tie (AB250)	3	

Removal: Cable Unit

- (1) Move the manipulator to the origin (0 pulse position).
- (2) Turn OFF the controller power.
- (3) Remove the covers and plates below.

For details, refer to *Maintenance: 3. Covers*.

Arm #4 side cover (Both sides)	User plate
Arm #3 head cover	Arm #3 bottom cover
Arm #2 side cover (Both sides)	Arm #1 side cover (Both sides)
Arm #1 center cover	Connector plate

When removing the user plate and connector plate, remove the parts below together.

- D-sub 9-pin connector
- Air tube × 4

- (4) Disconnect the connectors inside the base.
Connector:
X010, X020, X030, X040, X050, X060,
LEDA, (BR010, BR011), BR020, BR030,
BR040, BT1, X11, X12, X13, X14, X15, X16

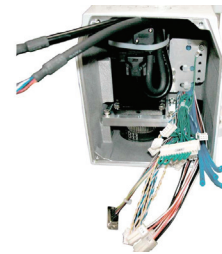

- (5) Cut off the wire ties which bind the cables inside Arm #3.

Remove the battery board inside Arm #1 and disconnect the following connectors from the battery board.

- Connector:
X61, X62, X63, X64

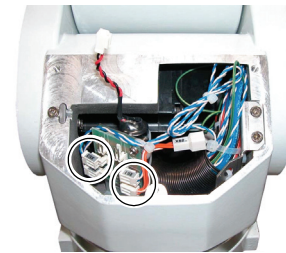

- (6) Remove the wire ties binding the cables.

Disconnect the connector of inside Arm #3.

- Connector:
X71, X72, X041, X051, X061,
LEDB, (BR041), BR051,(BR061),
BT4, BT5, BT6, X141, X151, X161

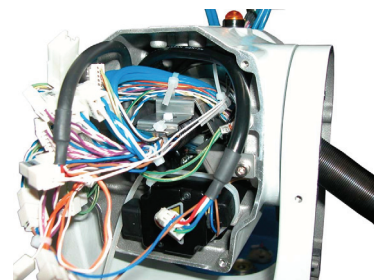

- (7) Disconnect the connector from the motors of Joint #2 and #3.

- Connector: X021, X121, BR021, X031, X131, BT3, BR031

- (8) Remove the parts below from Arm #4.
- Arm #4 cable fixing plate (2-M4×10)
 - Ground wire (M4×10)
- (9) Cut off 4 wire ties of the Arm #4 cable fixing plate.
- For binding the cables
 - For fixing the coil plate
 - For binding the special power supply
 - For fixing the special power supply plate

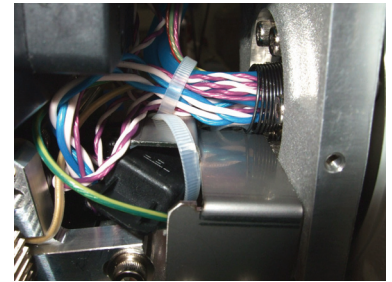

- (10) Remove the parts below from Arm #3.
- Arm #3 cable fixing plate (2-M4×5)
 - Ground wire × 2 (2-M4×5)
- (11) Cut off the 6 wire ties of Arm #3 cable fixing plate.

- (12) Pull out the air tube alone toward Arm #2.
- Pull out the cables below toward Arm #3.

- Joint #5 motor cable, brake cable
- Joint #6 motor cable, brake cable
- Cable for installed wire for customer use (X71, X72, X051, X061, X151, X161, BR051, (BR061), BT5, BT6)

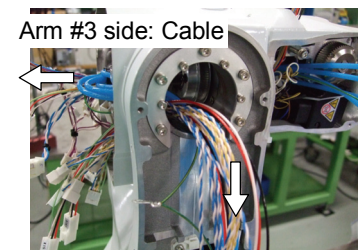

Arm #3 side: Cable

Arm #2: Air tube

When pulling out cables, carefully treat cables and connectors.

Pull out the cables in the order of connector size, from smallest to largest.

- (13) Cut off the 3 wire ties of Arm #2 and disconnect 2 ground wires (2-M4×5).

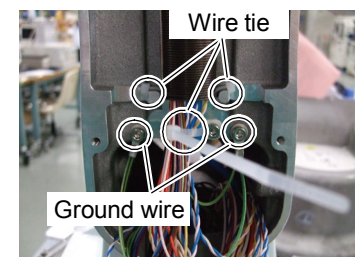

Wire tie

Ground wire

- (14) Pull out the cable unit of Arm #3 toward Arm #2.

Carefully treat cables and connectors to prevent damage to them.

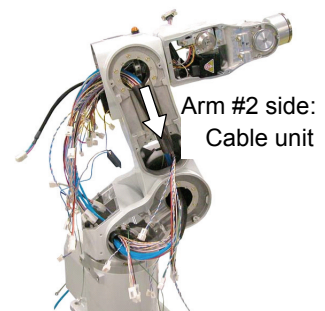

Arm #2 side: Cable unit

(15) Remove the Arm #2 cable fixing plate (2-M4×8).

There is no need to remove the fixing blot completely.

Remaining the bolt in Arm #2 makes it easy to mount the cable unit.

Pull out the cables toward Arm #1.

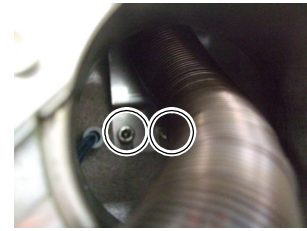

(16) Cut off 3 wire ties of Arm #1.

Disconnect 2 ground wires (2-M4×5).

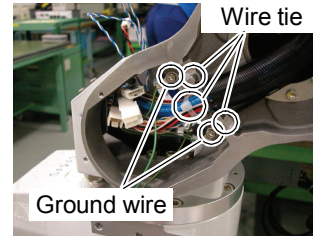

(17) Remove the Arm #1 cable fixing plate (2-M4×5).

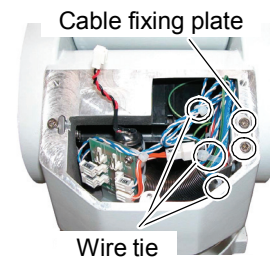

(18) Cut off 3 wire ties of Arm #1 cable fixing plate.

(19) Remove the parts below.

Base cable fixing plate (2-M4×8)

Ground wire (M4×5)

(20) Cut off 3 wire ties of base cable fixing plate.

Pull out the cables in the base side toward Arm #1.



(21) Pull out the cable unit from the base.

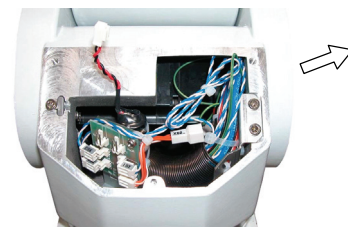

Installation: Cable Unit

- (1) Separate the cable unit.

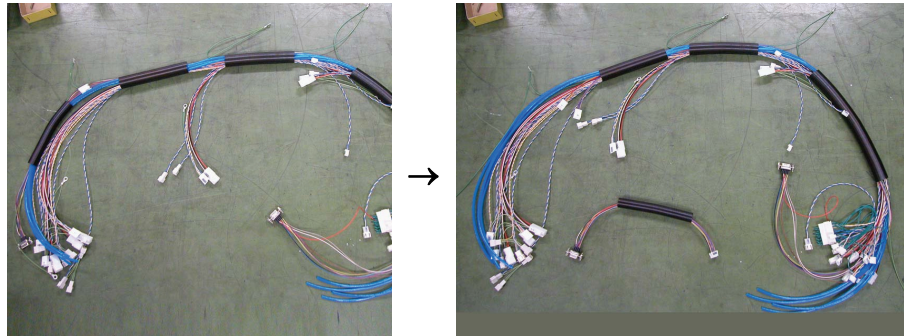

- (2) Apply the grease inside of cable protection spring (Krytox: 4 g)

Small-diameter spring : 0.5 g
 Spring (Length: 130 mm) : 1 g × 2
 Spring (Length: 230 mm) : 1.5 g

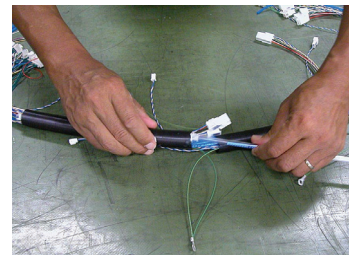

- (3) Secure the Arm #2 cable fixing plate and cable unit.

Plate and spring : Wire tie AB100
 Cable unit and plate : Wire tie AB150

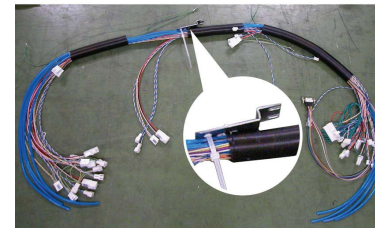

- (4) Prepare to mount the cable unit to the manipulator.
 Bind the cables. Be careful not to bind the ground wires together.
 (Wire tie: AB100 × 6)

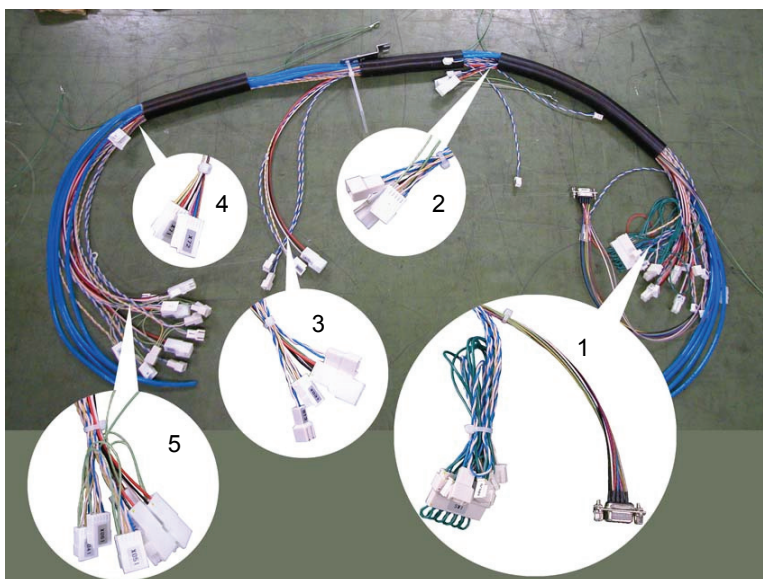

1. Connector
SW1, BR010, BR011, BR020, BR030, BR040, LEDA
2. Connector
X121, X021, BR021
3. Connector
X131, X031, BR031, BT3
4. Connector
X71, X72
5. Connector
X141, X151, X101, X041, X051, X061

- (5) For the manipulator with all axes brakes:
insert the Joint #6 brake cable toward the direction indicated in the right picture into the cable protection spring and secure the Joint #6 motor unit to Arm #4. (2-M4×15, 2-M4 washer)

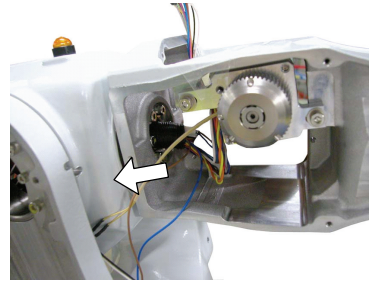

- (6) Insert the Joint #5 brake cable into the cable protection spring toward the direction indicated in the right picture. Loosely secure the Joint #5 motor unit to the opposite side from Arm #4. (2-M4×15, 2-M4 washer)

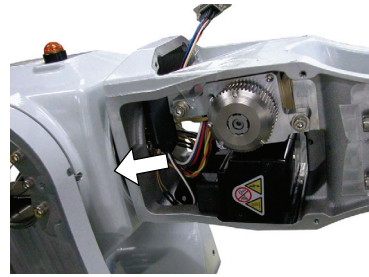

- (7) Insert the following connectors into the base side.

Signal cable: X010, X020, X030, X040,
LED-A, X050, X060
Power cable: X12, X13, X14, X15, X16

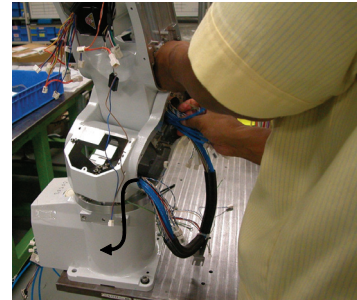

- (8) Insert the cable unit into Arm #2 and then Arm #3.

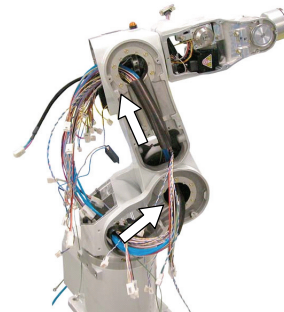

- (9) Pass the air tube and ground wire of cable unit through the cable protection spring (Small-diameter) and take them out from Arm #4.

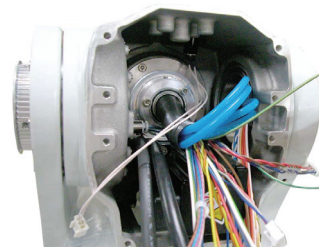

- (10) Secure the Arm #3 cables.
Loosely bind the cables so that you can adjust their location afterward.

[A] Bind 3 coils of cable protection spring in Arm #2 side (130 mm) to the Arm #3 cable fixing plate. (AB100)

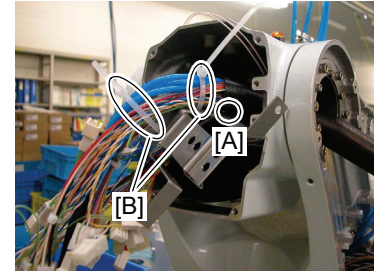

[B] Loosely bind the cables using 2 wire ties (AB150).

[C] Bind 3 cable protection springs (Small-diameter) to the Arm #3 cable fixing plate. (AB100)

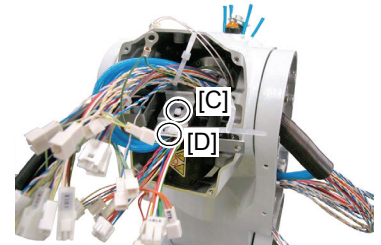

[D] Loosely bind the cables sticking out from Arm #4. (AB150)

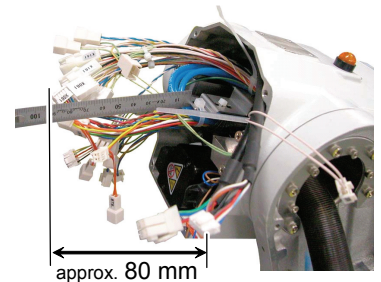

[E] Secure the Arm #3 cable fixing plate to Arm #3. (2-M4×5)

[F] Secure 2 ground wires (2-M4×5).

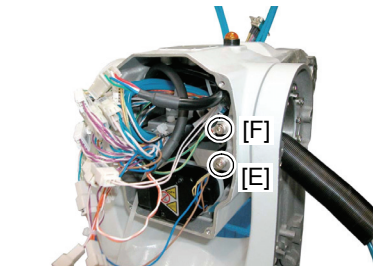

Connect the connectors.

Connector: X71, X72, X041, X051, X061, LEDB, (BR041), BR051, (BR061), BT4, BT5, BT6, X141, X151, X161

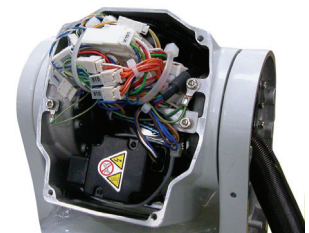

Bind the cables using 2 wire ties. (AB200)

(11) [A] Bind 3 cable protection springs (Small-diameter) to the Arm #4 cable fixing plate. (AB100)

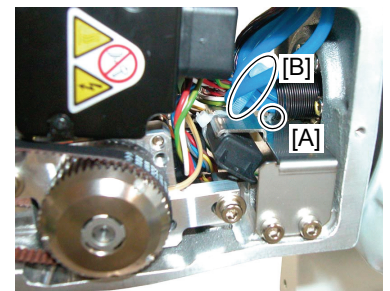

[B] Loosely bind the cables. (AB150)

(12) Secure the Arm #4 cable fixing plate to Arm #4. (2-M4×10)

- (13) Secure the ground wire to Arm #4.
Secure the brake special power supply to the Arm #4 cable protection plate. (AB150)

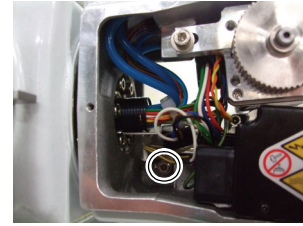

- (14) Secure the cable protection spring (130 mm) to Arm #2. (2-AB100)

- (15) Loosely secure the cables to the cable binder. (AB150)
To avoid the cables from scratching against the spring, put the cables up by 3 mm and secure them.

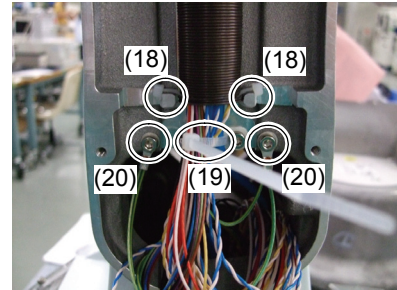

- (16) Secure 2 ground wires to Arm #2. (2-M4x5)
Connect the connector of the Joint #3 motor.

- (17) Secure the Arm #2 cable fixing plate to Arm #2. (2-M4x8)

- (18) Secure the cable protection spring (150 mm) to Arm #1. (2-AB100)

- (19) Loosely secure the cables to the cable binder. (AB150)

- (20) Secure 2 ground wires to Arm #1. (2-M4x5)

- (21) Secure the Arm #1 cable fixing plate to Arm #1. (2-M4x5)

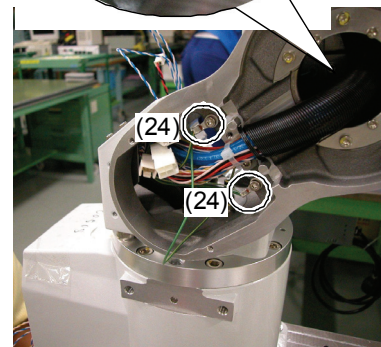
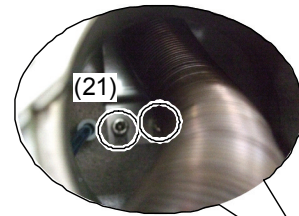

- (22) [A] Bind 3 coils of cable protection spring (230 mm) to the base cable fixing plate. (2 points: 2-AB100)

[B] Loosely secure the cables. (AB150)

- (23) Connect the connector of the Joint #2 motor.

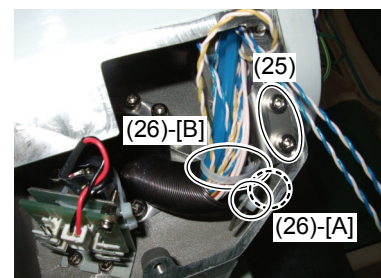

- (24) [A] Bind 3 coils of cable protection spring (230 mm) to the base cable fixing plate. (AB100)

[B] Loosely secure the cables. (2 points: 2-AB150)

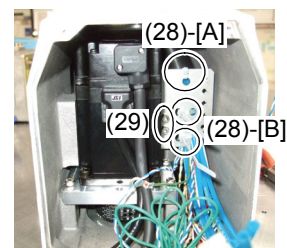

- (25) Secure the base cable fixing plate to the base. (2-M4×8)

To avoid the cables from scratching against the spring, put the cables up by 3 mm and secure them.

- (26) Secure the ground wires to the base cable fixing plate. (M4×5)

Secure the battery board to Arm #1.

Cut off the air tube at approx. 70 mm from the manipulator.

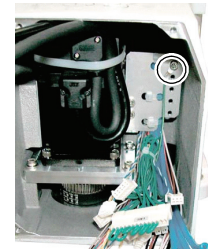

- (27) Adjust the length of whole cable unit and connect the all connectors below.

Connector:

X010, X020, X030, X040, X050, X060,
LEDA, (BR010, BR011), BR020, BR030,
BR040

BT1, X11, X12, X13, X14, X15, X16,
X61, X62, X63, X64, X021, X121,
BR021, X031, X131, BT3, BR031

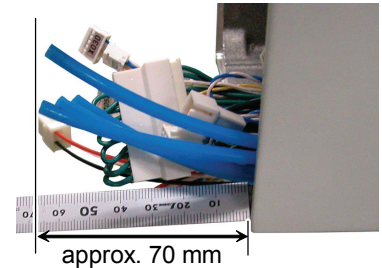

- (28) Bind the wire ties loosely bound previously.

- (29) Pull the air tube lightly and cut at 25 mm point.

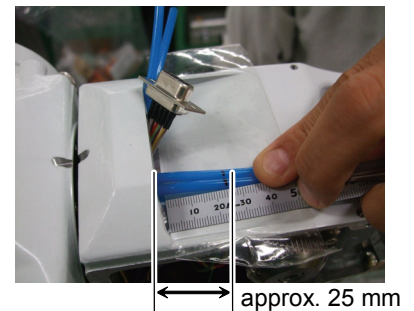

- (30) Secure the D-sub connector to the user plate and secure 4 air tubes.

Be careful of the direction of user plate.

- (31) Secure the user plate to Arm #4. (2-M3×6)

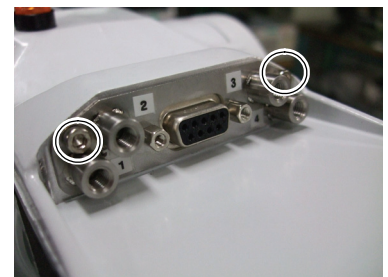

Check if there are any bended air tubes inside Arm #4.

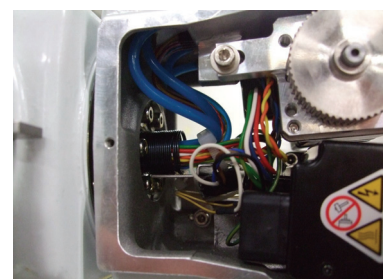

(32) Apply the tension to the Joint #5 motor unit and secure it.

For details, refer to *Maintenance: 9.1 Joint #5 – Replacing the Motor*, Installation step (4) to (8).

(33) Apply the tension to the Joint #6 motor unit and secure it.

For details, refer to *Maintenance: 10.1.1 Joint #6 motor (without electromagnetic brake)*, Installation step (4) to (8).

(34) Mount the covers and plates below.

Arm #4 side cover (Both sides)

Arm #3 head cover

Arm #2 side cover (Both sides)

Arm #1 center cover

Arm #3 bottom cover

Arm #1 side cover (Both sides)

Connector plate

For details, refer to *Maintenance: 3. Covers*.

(35) Perform the calibration.

For details, refer to *Maintenance: 16. Calibration*.

4.2 Connector Pin Assignments

4.2.1 Signal Cable

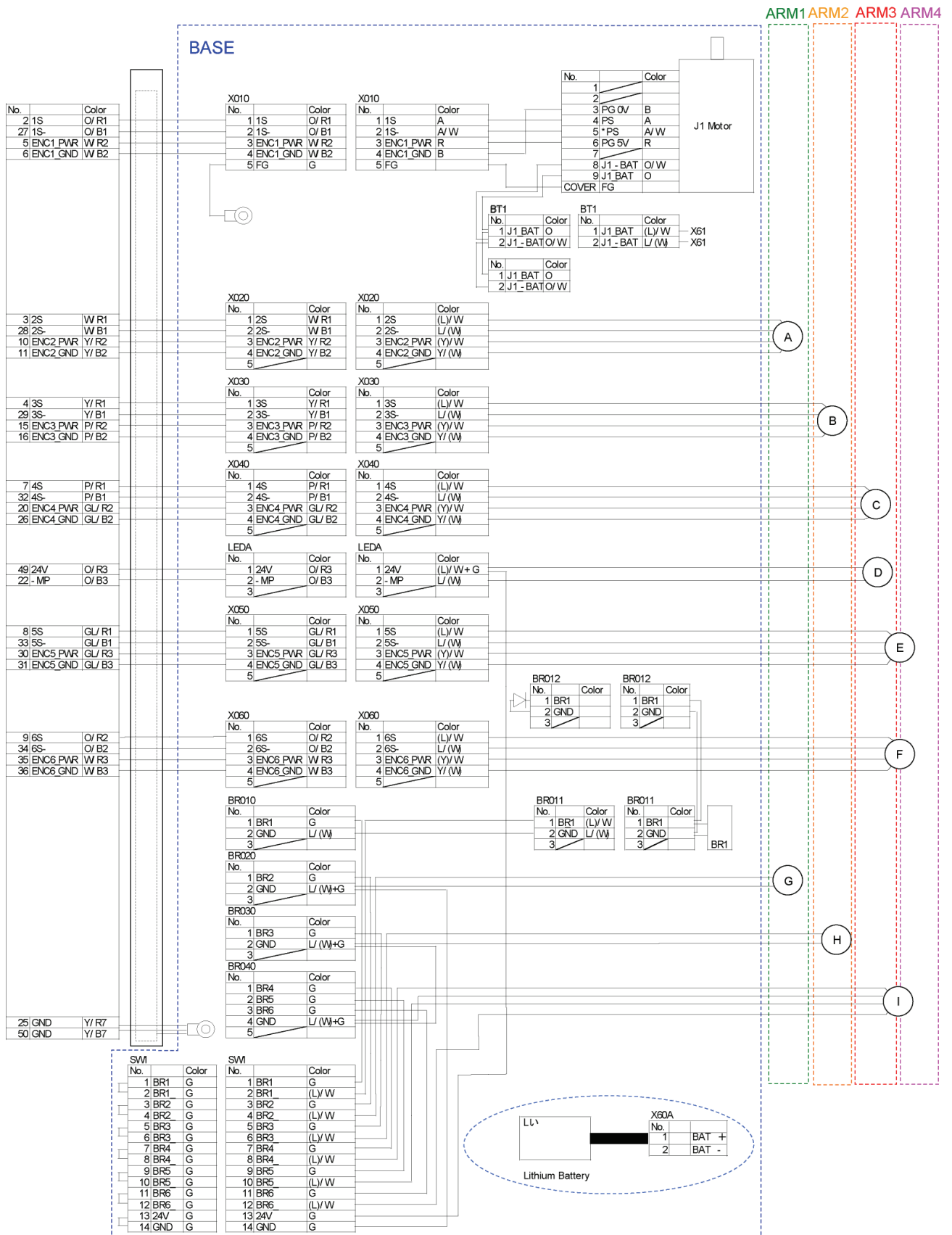

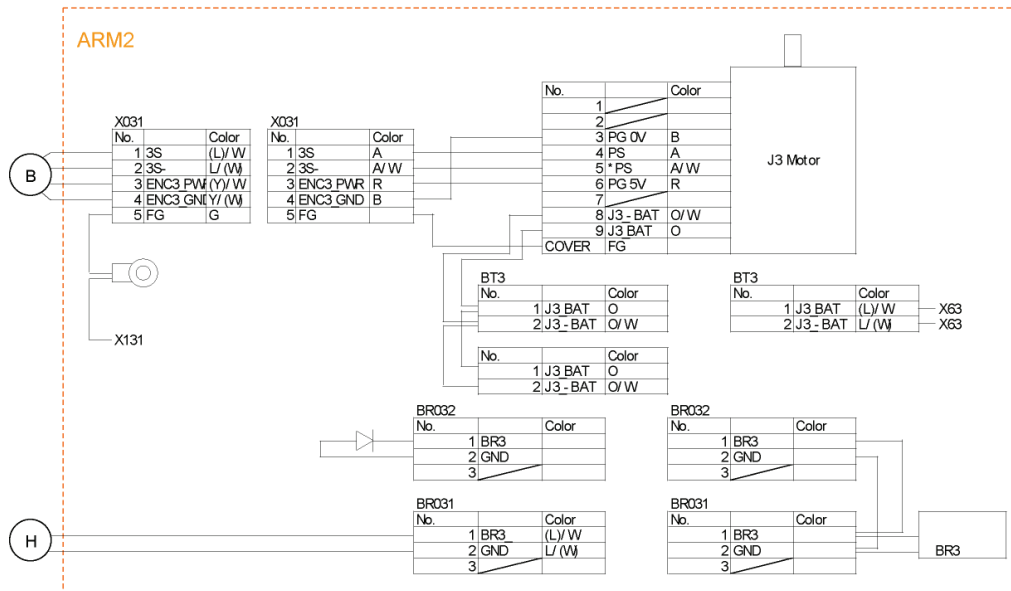
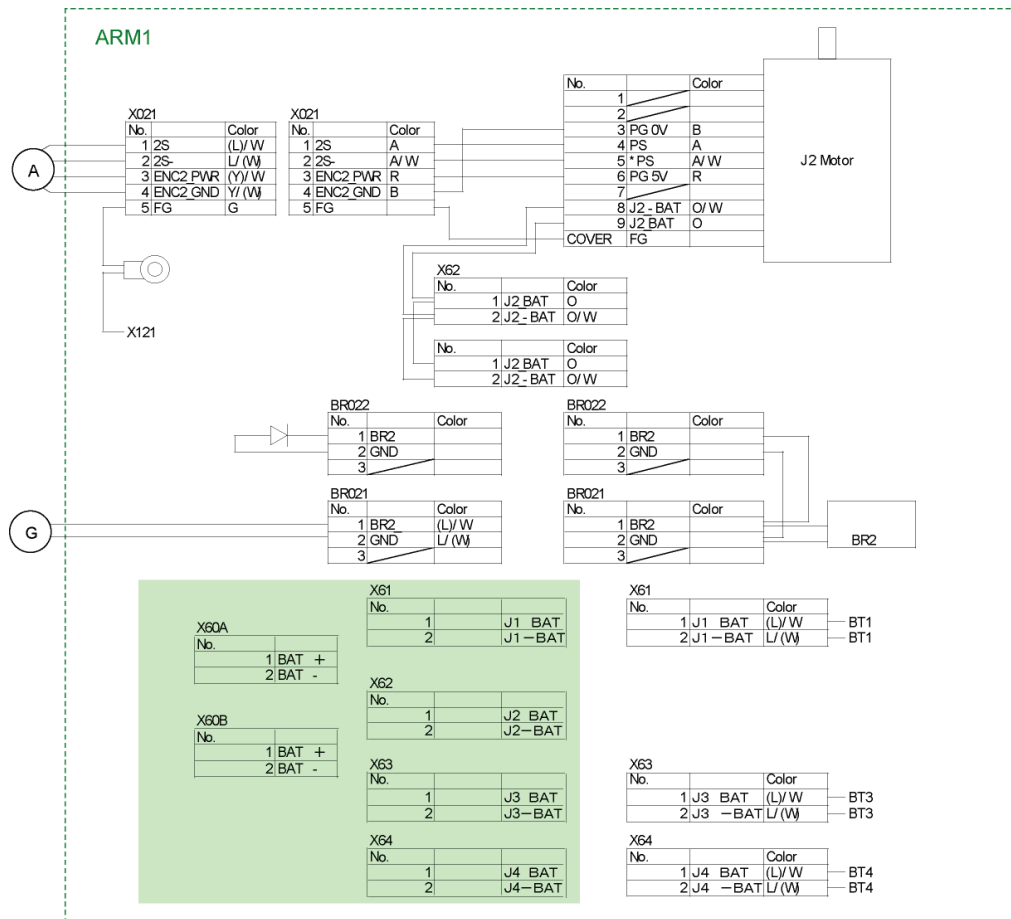

4.2.2 Power Cable

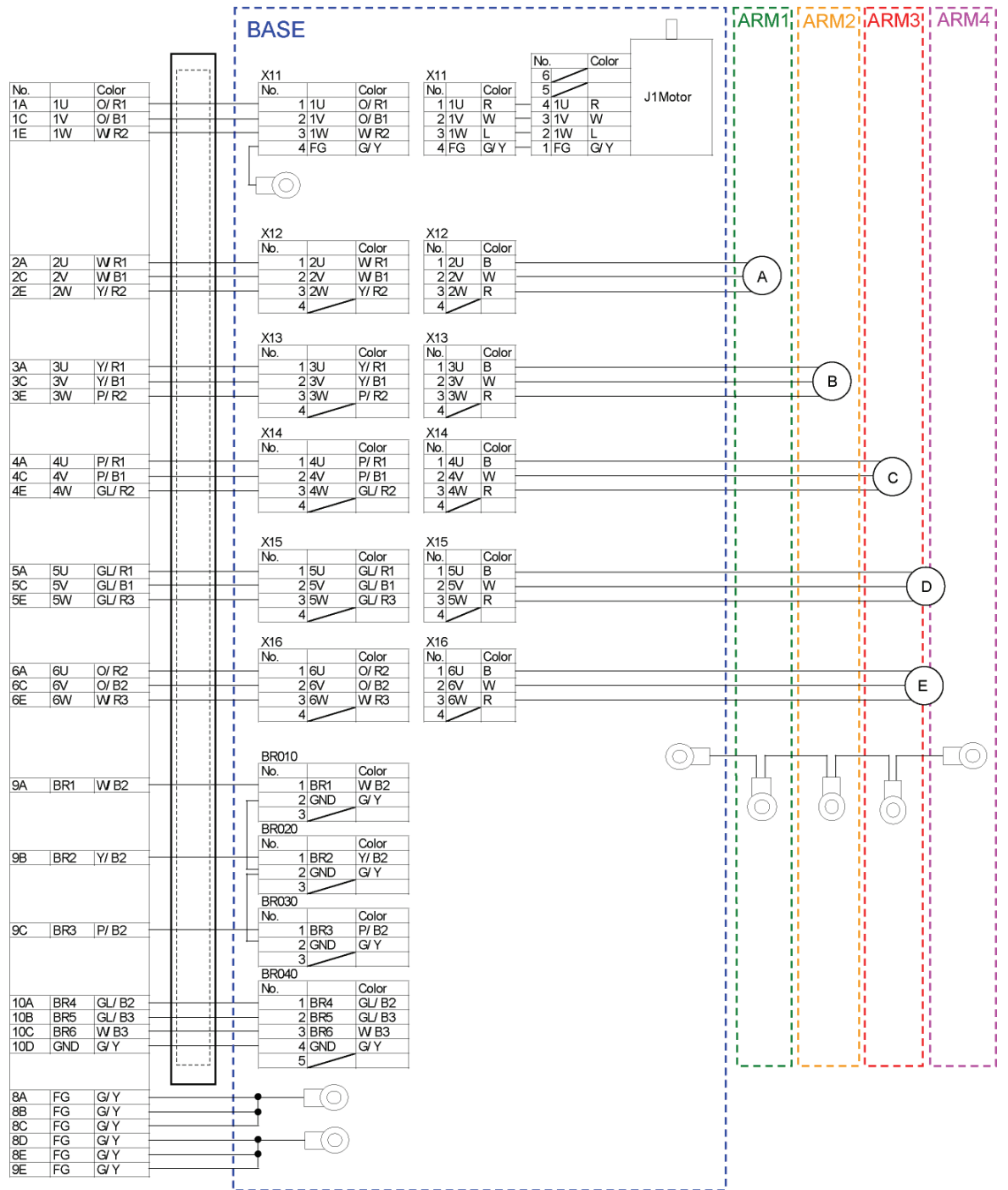

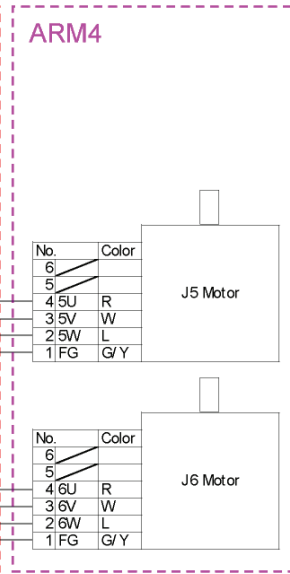
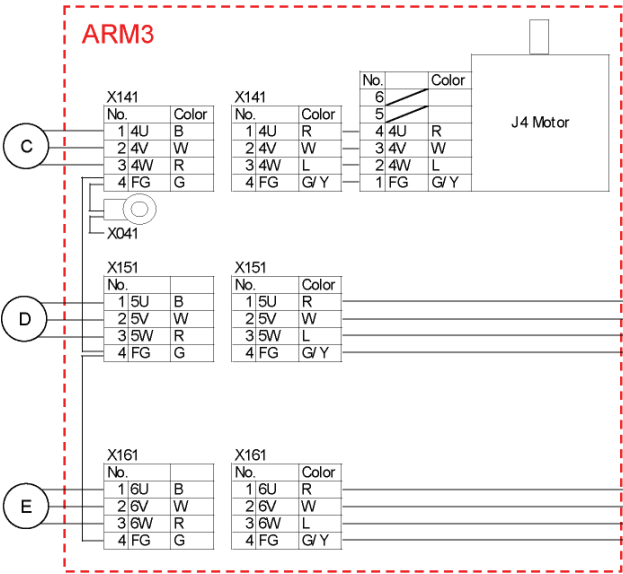
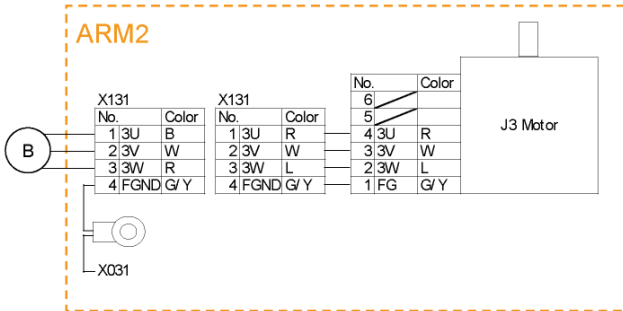
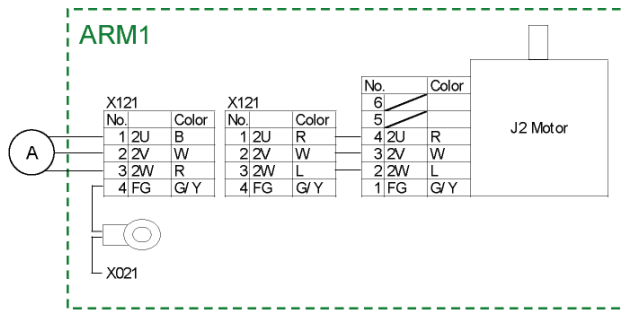

4.2.3 User Cable

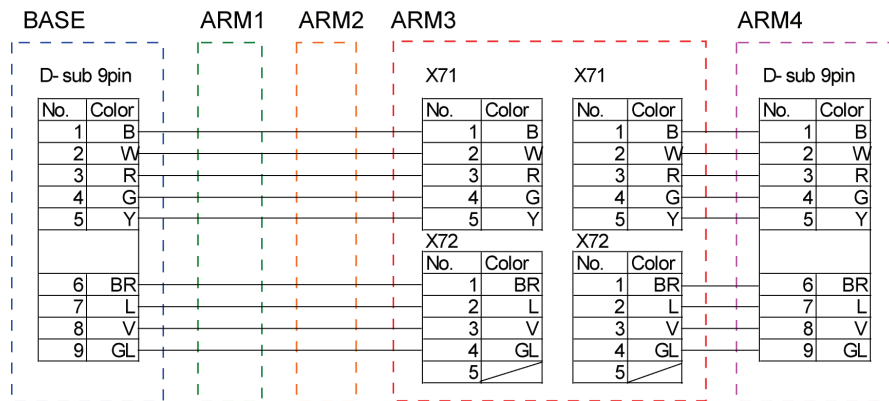

4.2.4 Color of Cables

The following table shows the codes and cable colors indicated in the following.

- 4.2.1 Signal Cable
- 4.2.2 Power Cable
- 4.2.3 User Cable

Code	Cable color
B	Black
W	White
R	Red
G	Green
Y	Yellow
BR	Brown
L	Blue
V	Violet
A	Azure
O	Orange
GL	Gray

5. Arm #1

 WARNING	<ul style="list-style-type: none"> ■ Before performing any replacement procedure, turn OFF the Controller and related equipment, and then pull out the power plug from the power source. Performing any replacement procedure with the power ON is extremely hazardous and may result in electric shock and/or malfunction of the robot system. ■ Do not insert or pull out the motor connectors while the power to the robot system is turned ON. Inserting or pulling out the motor connectors with the power ON is extremely hazardous and may result in serious bodily injury as the Manipulator may move abnormally, and also may result in electric shock and/or malfunction of the robot system. ■ Be sure to connect the AC power cable to a power receptacle. DO NOT connect it directly to a factory power source. To shut off power to the robot system, pull out the power plug from the power source. Performing any work while connecting the AC power cable to a factory power source is extremely hazardous and may result in electric shock and/or malfunction of the robot system.
--	---

 CAUTION	<ul style="list-style-type: none"> ■ Be careful not to apply excessive shock to the motor shaft during replacement procedures. The shock may shorten the life cycle of the motors and encoder and/or damage them. ■ Never disassemble the motor and encoder. Disassembled motor and encoder will cause a positional gap and cannot be used again.
--	---

After parts have been replaced (motors, reduction gear units, timing belts, etc.), the Manipulator cannot perform positioning properly because a mismatch exists between the origin stored in each motor encoder and its corresponding origin stored in the Controller. After replacing the parts, it is necessary to match these origins. The process of aligning the two origins is called “Calibration”. Refer to *Maintenance 16. Calibration* and follow the steps that pertain to the software you are using to perform the calibration.

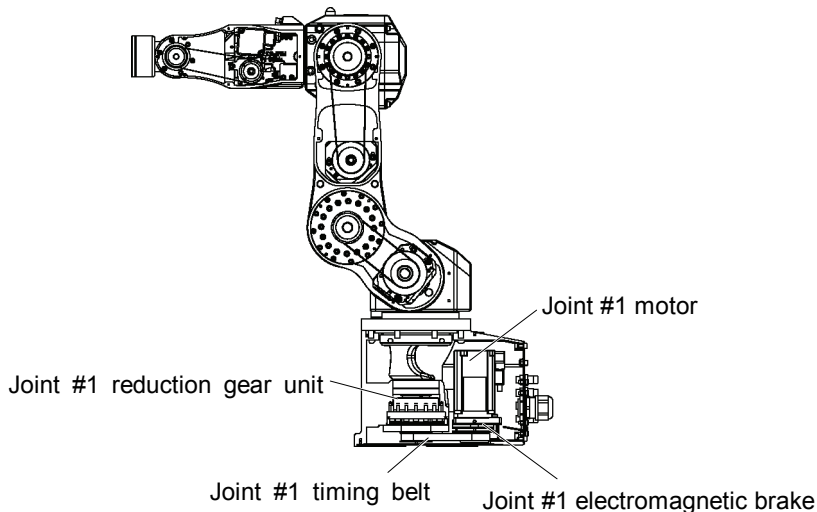

5.1 Replacing the Motor

Maintenance Part, Tools, and Material

	Name	Quantity	Note
Maintenance Parts	AC servo motor 400W	1	R13B000616
	Heat dissipating sheet	1	R13B031905
	Noise reduction diode	1	R13B020301
Tools	Hexagonal wrench (width across flats: 2.5 mm)	1	For M5 set screw
	Hexagonal wrench (width across flats: 3 mm)	1	For M4 screw
	Hexagonal wrench (width across flats: 4 mm)	1	For M5 screw
	Cross-point screwdriver	1	For motor connector
	Force gauge	1	For belt tension

5.1.1 Joint #1 motor (without electromagnetic brake)

Removal: Joint #1 motor (without electromagnetic brake)

- (1) Turn ON the controller power.
- (2) Remove the connector plate.

For details, refer to *Maintenance: 3. Covers*.

- (3) Disconnect the connectors.
 Connector: X11, X010 (Hold the claw to remove.)
 Connector: BT1

- (4) Remove the Joint #1 motor unit from the base.

To remove the screw fixed to the rear of the motor unit, put a hexagonal wrench through the hole after removing the cap.

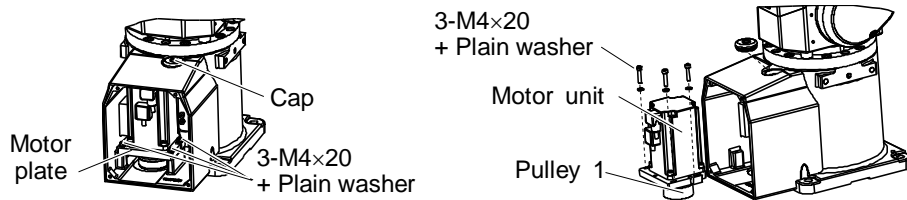

- (5) Remove the pulley 1 from Joint 1 motor unit.

There is a brass bushing in one of the set screw. Be careful not to lose it.

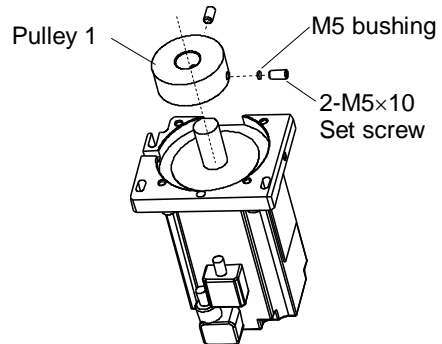

- (6) Remove the motor plate from Joint #1 motor.

- (7) Remove the radiating sheet attached to the Joint #1 motor.

The sheet is very soft, be careful not to break.

- (8) Remove the motor cable from the Joint #1 motor.

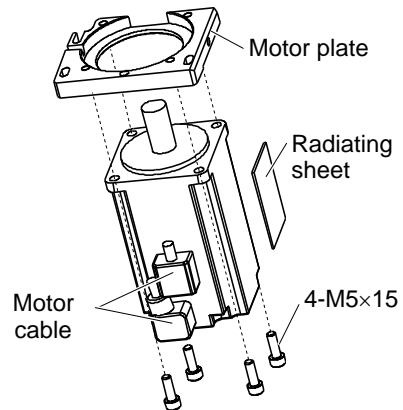

Installation: Joint #1 motor (without electromagnetic brake)

- (1) Mount the motor cable to the Joint #1 motor.

- (2) Mount the motor plate to the Joint #1 motor.

Be careful of the direction of motor plate.
(See the figure.)

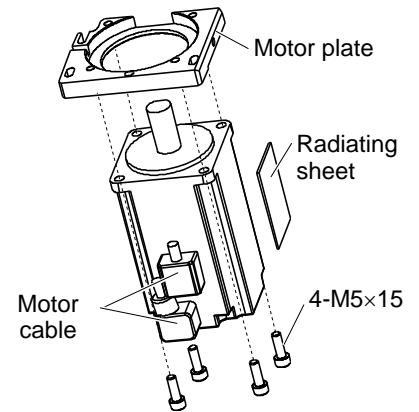

- (3) Mount the pulley 1 to the Joint #1 motor.

Put a space of 10 mm between the pulley 1 and motor plate.

Use the bushing into the hole that is fixed with the round face of the motor shaft.

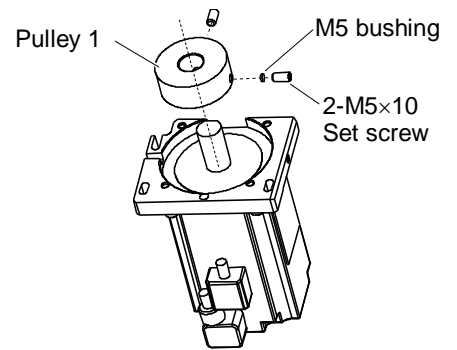
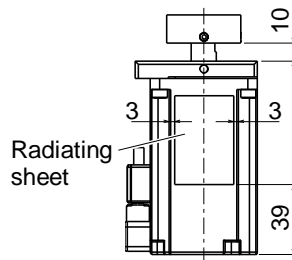

- (4) Attach the radiating sheet to the Joint #1 motor.

- (5) Place the Joint #1 timing belt around the Joint #1 pulley 2 in the Joint #1 side.

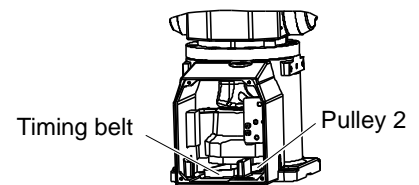

- (6) Pass the pulley 1 of Joint #1 motor unit to the Joint #1 timing belt and loosely secure it to the base.

Make sure that the gear grooves of the timing belt are fit into those of the pulley completely.

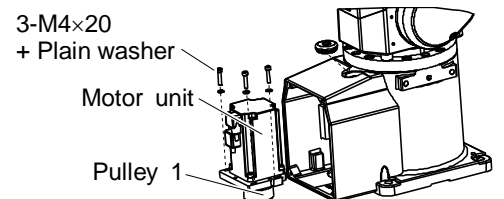

When securing loosely the motor unit, make sure the motor unit can be moved by hand, and it will not tilt when pulled. If the unit is secured too loose or too tight, the belt will not have the proper tension.

- (7) Apply the proper tension to the Joint #1 motor unit to secure it.

Pass a suitable cord or string (INSULOK) to the screw. Then, pull the cord using a force gauge or similar tool to apply the specified tension. At this point, apply tension by pressing toward the “A” surface in the figure and secure the motor unit.

Joint #1 timing belt tension: $78.4 \text{ N} \pm 9.8 \text{ N}$ (8 kgf \pm 1 kgf)

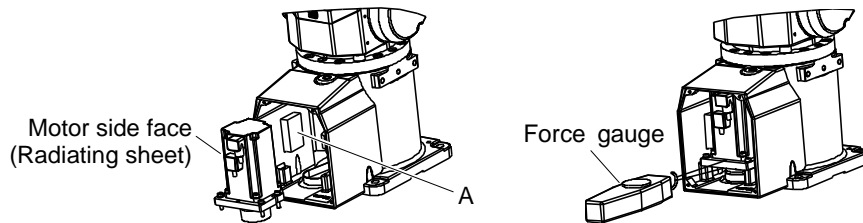

- (8) Connect the connectors.

Connectors: X11, X010, BT1

- (9) Mount the connector plate.

For details, refer to *Maintenance: 3. Covers*.

- (10) Perform the calibration for Joint #1.

For details, refer to *Maintenance: 16. Calibration*.

5.1.2 Joint #1 motor (with electromagnetic brake)

Removal: Joint #1 motor (with electromagnetic brake)

- (1) Remove the Joint #1 motor unit.

For details, refer to *Maintenance: 5.1.1 Joint #1 motor (without electromagnetic brake)*, Removal step (1) to (4).

When disconnecting the connectors, disconnect the following together.

Connector: BR011

Be careful not to lose the noise reduction diode.

- (2) Remove the Joint #1 pulley 1 and driving boss from the Joint #1 motor unit.

There is a brass bushing in one of the set screws fixing the driving boss and pulley 1.

Be careful not to lose it.

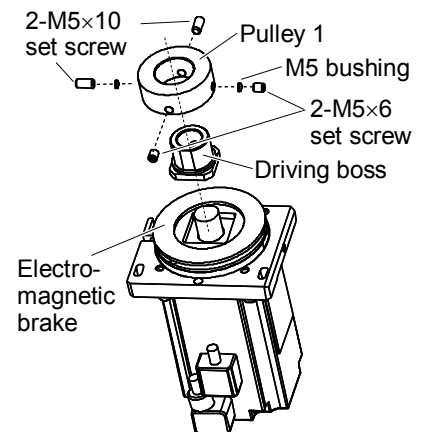

- (3) Remove the electromagnetic brake.

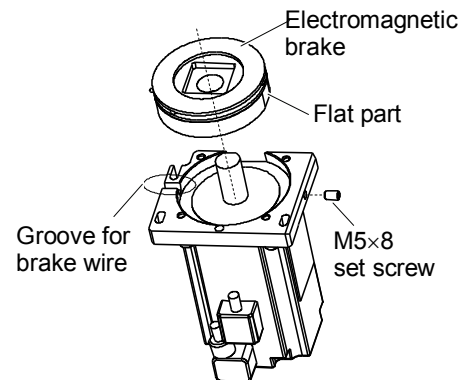

- (4) Remove the Joint #1 motor.

For details, refer to *Maintenance: 5.1.1 Joint #1 motor (without electromagnetic brake)*, Removal step (6) to (8).

Installation: Joint #1 motor (with electromagnetic brake)

- (1) Assemble the motor.
For the detail, refer to the *Maintenance: 5.1.1 Joint #1 motor (without electromagnetic brake) – Installation step (1) to (2)*.

- (2) Mount the Joint #1 electromagnetic brake to the Joint #1 motor unit.

Align the position of brake wire with the groove in motor plate. Then, put the flat part of brake to the side of set screw and secure the brake.

Be careful not to catch the brake wire in the motor plate and cut it off.

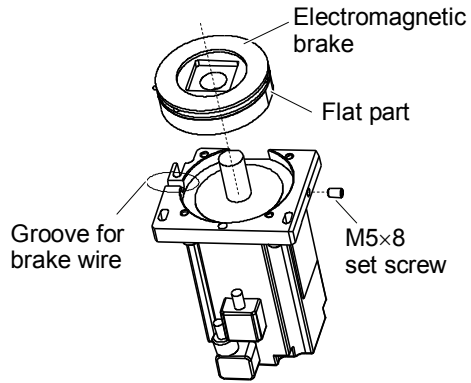

Press the brake toward the motor plate and tighten the set screw.

- (3) Mount the noise dissipative diode to the wire of electromagnetic brake.

Connector: BR011

- (4) Mount the driving boss and pulley 1 to the Joint #1 motor unit.

Align the edges of driving boss and pulley 1. Put a space of 0.5 mm between the pulley 1 and electromagnetic brake. See the figure for the position of set screws.

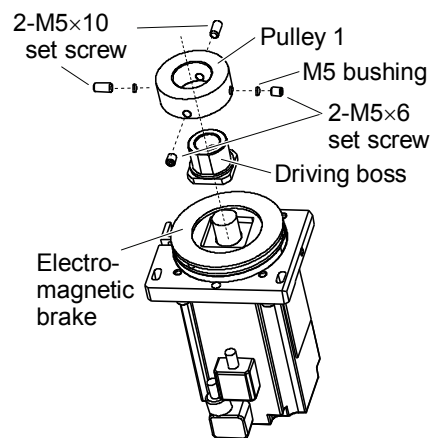
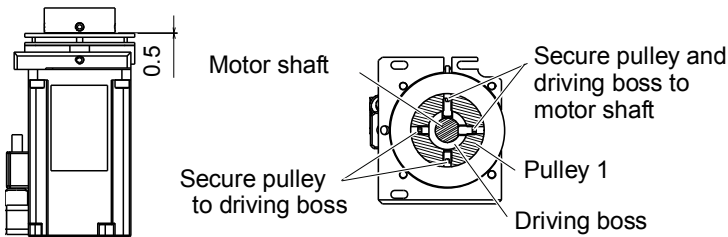

- (5) Mount the Joint #1 motor unit.

For details, refer to *Maintenance: 5.1.1 Joint #1 motor (without electromagnetic brake)*, Installation step (4) to (10).

5.2 Replacing the Reduction Gear Unit

A reduction gear unit consists of the following three parts. Also, two additional parts are included as accessories. When replacing the reduction gear unit, be sure to always replace these parts all together as one set.

Reduction gear unit: Wave generator / Flexspline / Circular spline

Accessory: Spacer / Grip ring

Refer to the Maintenance: 17. Maintenance Parts List for details.

We recommend replacing the O-ring when replacing the reduction gear unit.

Maintenance Parts and Tools

	Name	Quantity	Note
Maintenance Parts	Joint #1 reduction gear	1	R13B010011
	Grease for reduction gear (SK-1A)	1	R13ZA00330100
	Joint #1 O-ring	1	R13B031223
Tools	Hexagonal wrench (width across flats: 2.5 mm)	1	For M5 screw
	Hexagonal wrench (width across flats: 3 mm)	1	For M4 screw
	Hexagonal wrench (width across flats: 5 mm)	1	For M6 screw
	Force gauge	1	For belt tension
	Wiping cloth	2	For wiping grease

Removal: Joint #1 reduction gear unit

- (1) Turn OFF the controller power supply.
- (2) Turn the Manipulator laterally.

 CAUTION	<p>■ When turning the Manipulator laterally, there must be two or more people to work on it so that at least one of them can support the arm while others are removing the bolts. Removing the bolts without supporting the arm may result in the arm falling, bodily injury, and/or malfunction of the robot system.</p>
---	---

- (3) Remove the connector plate and base bottom cover.

For details, refer to *Maintenance: 3. Covers*.

- (4) Loosen the set screw of the Joint #1 motor unit and remove the Joint #1 timing belt.

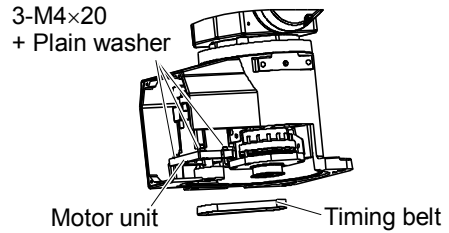

- (5) Remove the Joint #1 reduction gear unit from the base.

Wipe the grease from the parts while the work.

- (6) Remove the parts below from Arm #2.
 - Circular spline
 - Grip ring
 - Flexspline
 - Spacer

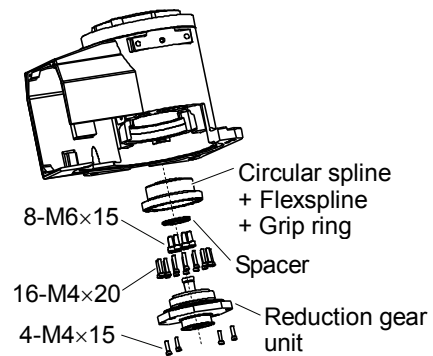

Wipe the grease from the parts while the work.

- (7) Remove the wave generator from the Joint #1 reduction gear unit.

At this point, remove the bearing together. Be careful not to lose the bearing which is necessary afterward.

There is a brass bushing in one of the set screws. Be careful not to lose it.

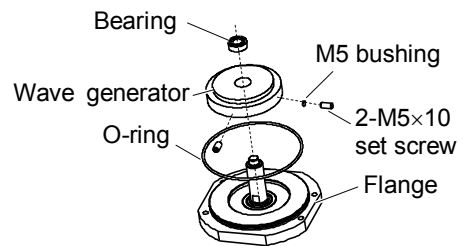

- (8) Remove the O-ring.
- (9) Wipe the grease using a cloth or similar thing if the grease is attached to the base, etc.

Installation: Joint #1 reduction gear unit

- (1) Mount the wave generator and bearing to the Joint #1 reduction gear unit.

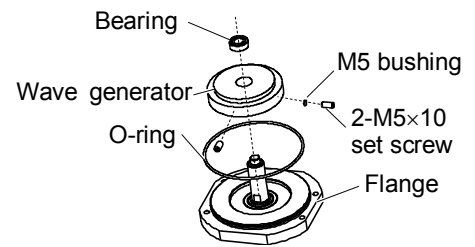

- (2) Put the O-ring into the groove in the flange.

Carefully assemble these parts to avoid damaging the O-ring.
(Otherwise the grease will leak.)

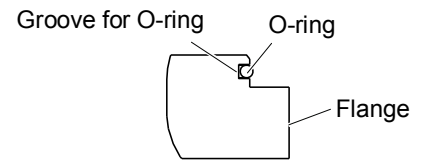

- (3) Apply the grease (SK-1A) to the bearing area of wave generator.
- (4) Mount the parts below to the base.

- Circular spline
- Grip ring
- Flexspline
- Spacer

Note that screw tightening torque is different from the normal torque.
 16-M4x20 : 0.59 N·m (60 kgf·cm)
 8-M6x15 : 2.2 N·m (220 kgf·cm)

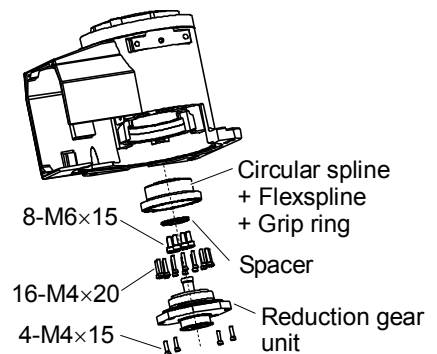

- (5) Apply the grease (SK-1A) to inside of flexspline.

Grease volume: 40 g

- (6) Mount the Joint #1 reduction gear unit to the base.

- (7) Place the Joint #1 timing belt around the Joint #1 pulley 2 and then pulley 1.

Make sure that the gear grooves of the timing belt are fit into those of the pulley completely.

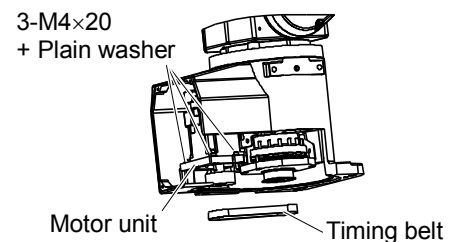

- (8) Loosely secure the Joint #1 motor unit.

Make sure the motor unit can be moved by hand, and it will not tilt when pulled.
If the unit is secured too loose or too tight, the belt will not have the proper tension.

- (9) Mount the Arm #1 motor unit.

For details, refer to *Maintenance: 5.1.1 Joint #1 motor (without electromagnetic brake)*, Installation step (7) to (10).

5.3 Replacing the Timing Belt

Maintenance Part and Tools

	Name	Quantity	Note
Maintenance Part	Joint #1 Timing belt	1	R13B030220
Tools	Hexagonal wrench (width across flats: 3 mm)	1	For M4 screw
	Force gauge	1	For belt tension Belt tension: 8 kgf·cm

Removal: Joint #1 timing belt

- (1) Remove the Joint #1 motor unit.

For details, refer to *Maintenance: 5.1.1 Joint #1 motor (without electromagnetic brake)*, Removal step (1) to (4).

- (2) Remove the Joint #1 timing belt.

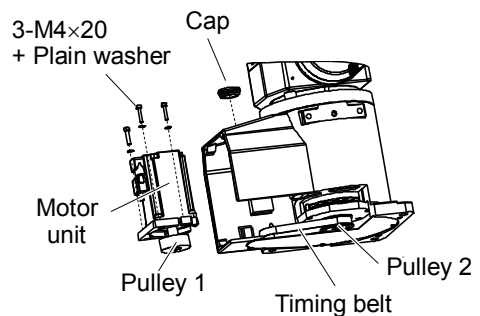

Installation: Joint #1 timing belt

- (1) Place the Joint #1 timing belt around the Joint #1 pulley 2.

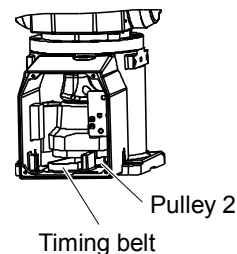

- (2) Mount the Joint #1 motor unit.

For details, refer to *Maintenance: 5.1.1 Joint #1 motor (without electromagnetic brake)*, Installation step (6) to (10).

5.4 Replacing the Electromagnetic Brake

Maintenance Parts and Tools

	Name	Quantity	Note
Maintenance Parts	Joint #1 electromagnetic brake	1	R13B030504
	Noise dissipative diode	1	R13B020301
Tools	Hexagonal wrench (width across flats: 2.5 mm)	1	For M5 screw
	Hexagonal wrench (width across flats: 3 mm)	1	For M4 screw
	Force gauge	1	For belt tension

Removal: Joint #1 electromagnetic brake

Remove the Joint #1 electromagnetic brake from the Joint #1 motor unit.

For details, refer to *Maintenance: 5.1.2 Joint #1 motor (with electromagnetic brake)*, Removal step (1) to (3).

Installation: Joint #1 electromagnetic brake

- (1) Assemble the Joint #1 motor unit.

For details, refer to *Maintenance: 5.1.2 Joint #1 motor (with electromagnetic brake)*, Installation step (2) to (4).

- (2) Mount the Joint #1 motor unit.

For details, refer to *Maintenance: 5.1.1 Joint #1 motor (without electromagnetic brake)*, Installation step (5) to (10).

6. Arm #2

 WARNING	<ul style="list-style-type: none"> ■ Before performing any replacement procedure, turn OFF the Controller and related equipment, and then pull out the power plug from the power source. Performing any replacement procedure with the power ON is extremely hazardous and may result in electric shock and/or malfunction of the robot system. ■ Do not insert or pull out the motor connectors while the power to the robot system is turned ON. Inserting or pulling out the motor connectors with the power ON is extremely hazardous and may result in serious bodily injury as the Manipulator may move abnormally, and also may result in electric shock and/or malfunction of the robot system. ■ Be sure to connect the AC power cable to a power receptacle. DO NOT connect it directly to a factory power source. To shut off power to the robot system, pull out the power plug from the power source. Performing any work while connecting the AC power cable to a factory power source is extremely hazardous and may result in electric shock and/or malfunction of the robot system.
--	---

 CAUTION	<ul style="list-style-type: none"> ■ Be careful not to apply excessive shock to the motor shaft during replacement procedures. The shock may shorten the life cycle of the motors and encoder and/or damage them. ■ Never disassemble the motor and encoder. Disassembled motor and encoder will cause a positional gap and cannot be used again.
--	---

After parts have been replaced (motors, reduction gear units, timing belts, etc.), the Manipulator cannot perform positioning properly because a mismatch exists between the origin stored in each motor encoder and its corresponding origin stored in the Controller. After replacing the parts, it is necessary to match these origins. The process of aligning the two origins is called “Calibration”. Refer to *Maintenance 16. Calibration* and follow the steps that pertain to the software you are using to perform the calibration.

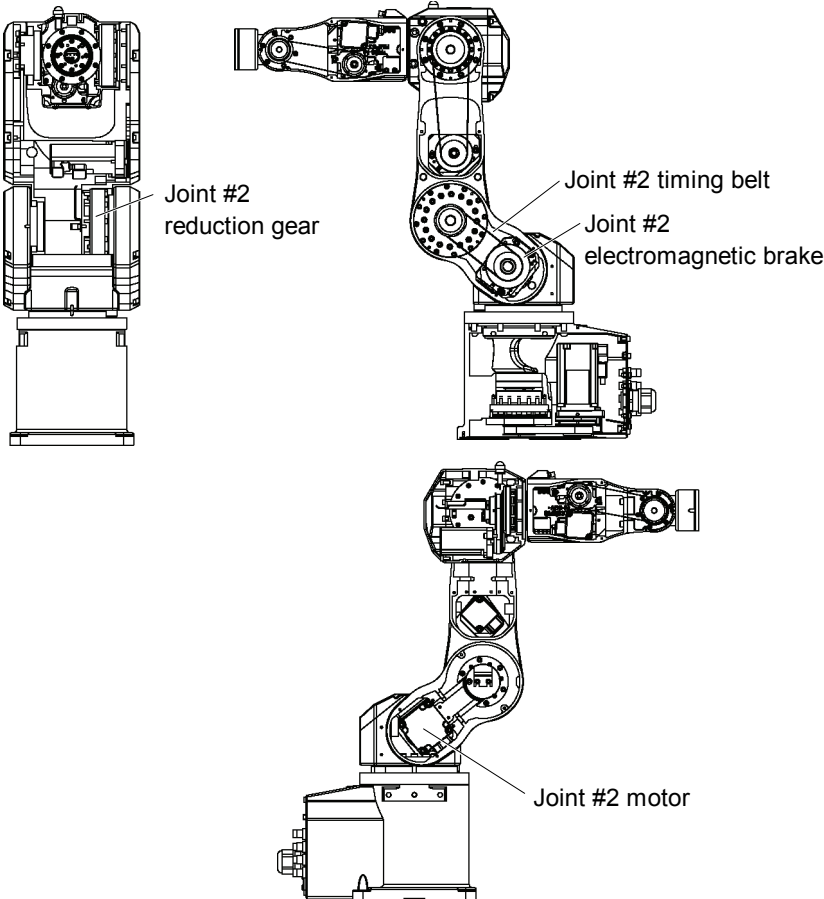

6.1 Replacing the Motor

Maintenance Parts, Tools, and Material

	Name	Quantity	Note
Maintenance Parts	AC servo motor 400W	1	R13B000616
	Radiating sheet	1	R13B031905
	Noise reduction diode	1	R13B020301
Tools	Hexagonal wrench (width across flats: 2.5 mm)	1	For M5 set screw
	Hexagonal wrench (width across flats: 3 mm)	1	For M4 screw
	Hexagonal wrench (width across flats: 4 mm)	1	For M5 screw
	Cross-point screwdriver	1	For motor connector
	Cloth	1	For pressing arm
	Force gauge	1	For belt tension

The brake is equipped to Joint #2 to prevent the arm from lowering for its own weight while the controller power is OFF or the motor is OFF status. However, the brake does not work during replacement.

To replace the Joint #2 motor, tilt Arm #2 and press toward Arm #1. (See the step (2).)

When pressing the arm, be sure to avoid the each arm from contacting by putting a cloth or similar thing between the arms. This also protects the arm surfaces and coatings.

Removal : Joint #2 motor

- (1) Turn ON the controller power.
- (2) Tilt Arm #2.

Put a cloth between Arm #1 and Arm #2 so that two arms do not touch each other.

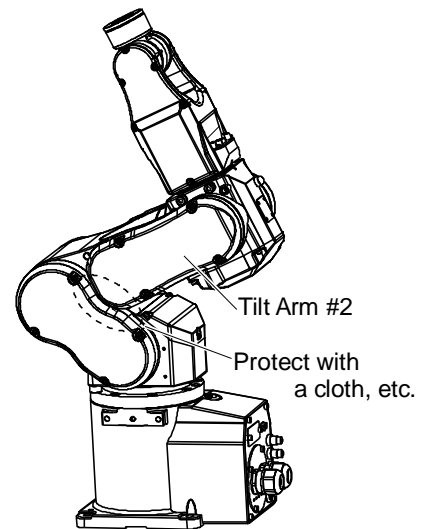

- (3) Turn OFF the controller power.
- (4) Remove the Arm #1 cover and Arm #1 side cover.

For details, refer to *Maintenance: 3. Covers*.

- (5) Disconnect the connectors.
 Connector: X121, X021 (Hold the claw to remove.)
 Connector: X62, BR021

- (6) Remove the Joint #2 motor unit from Arm #1.

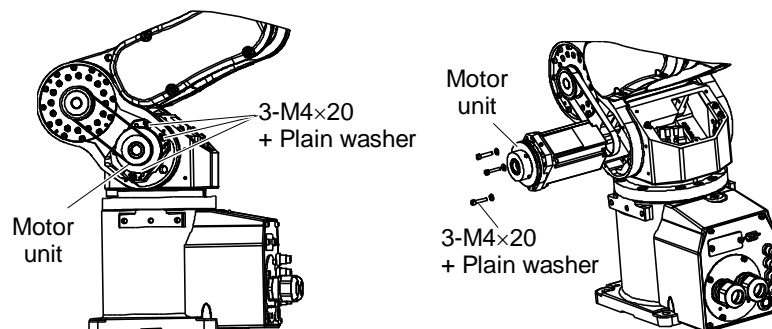

- (7) Disconnect the connector.
 Connector: BR022 (for the noise dissipative diode)

Be careful not to lose the noise dissipative diode.

- (8) Remove the Joint #2 pulley 1 and driving boss from Joint #2 motor unit.

There is a brass bushing in one of the set screw fixing the driving boss and pulley.

Be careful not to lose it.

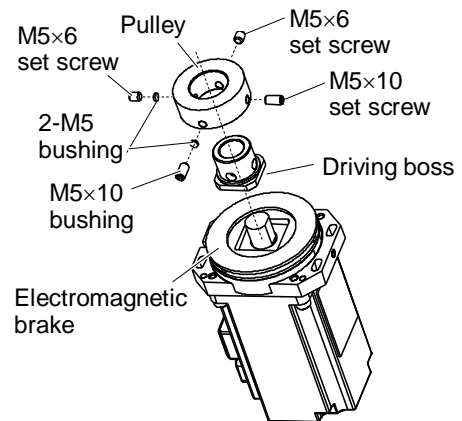

- (9) Remove the Joint #2 electromagnetic brake.

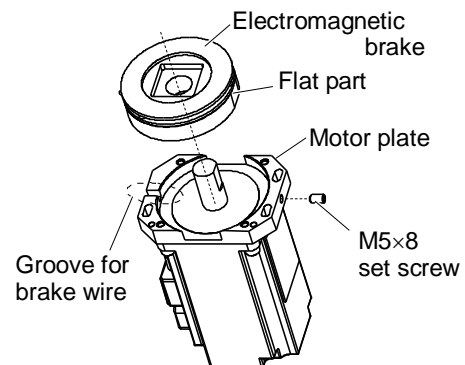

- (10) Remove the motor plate from Joint #2 motor.

- (11) Remove the radiating sheet attached to the Joint #2 motor side.

The sheet is very soft, be careful not to break.

- (12) Remove the motor cable from the Joint #2 motor.

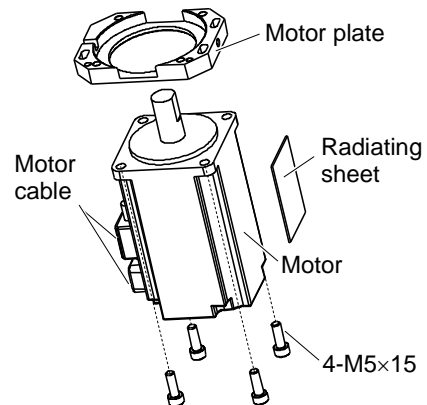

Installation: Joint #2 motor

- (1) Mount the motor cable to the Joint #2 motor.
- (2) Mount the motor plate to the Joint #2 motor.

Be careful of the direction of motor plate.
See the figure.

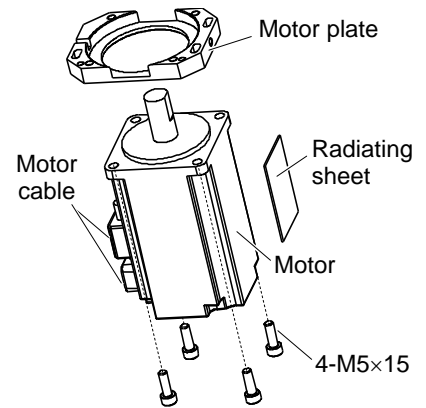

- (3) Mount the Joint #2 electromagnetic brake to the Joint #2 motor unit.

Align the position of brake wire with the groove in motor plate. Then, put the flat part of brake to the side of set screw and secure the brake. Be careful not to catch the brake wire in the motor plate and cut it off.

Press the brake toward the motor plate and tighten the set screw.

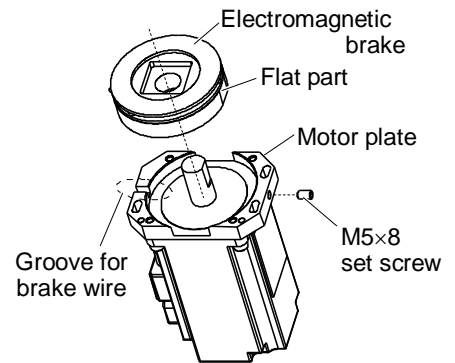

- (4) Mount the noise dissipative diode to the wire of electromagnetic brake.
Connector: BR022

- (5) Mount the driving boss and pulley 1 to the Joint #2 motor unit.

Align the edges of driving boss and pulley 1. Put a space of 0.5 mm between the pulley 1 and electromagnetic brake. See the figure for the position of set screws.

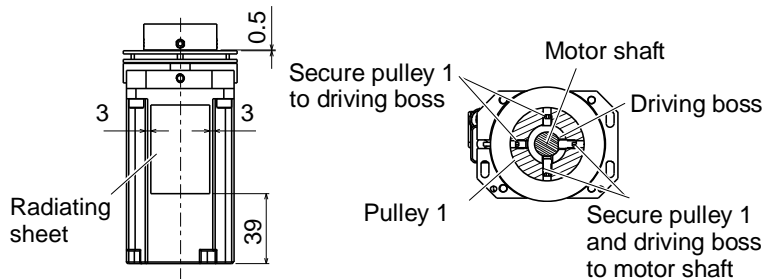
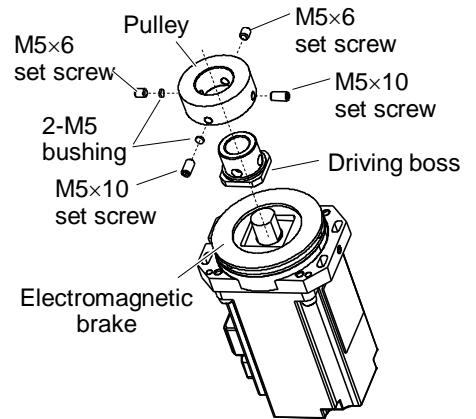

- (6) Mount the radiating sheet.

- (7) Place the Joint #2 timing belt around the Joint #2 pulley 2.

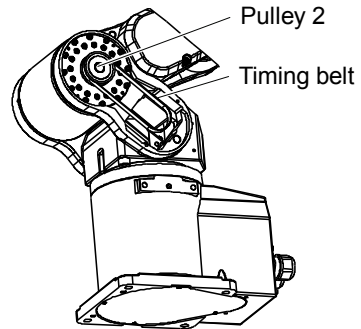

- (8) Pass the pulley 1 of Joint #2 motor unit to the Joint #2 timing belt and loosely secure it to Arm #1.

Make sure that the gear grooves of the timing belt are fit into those of the pulley completely.

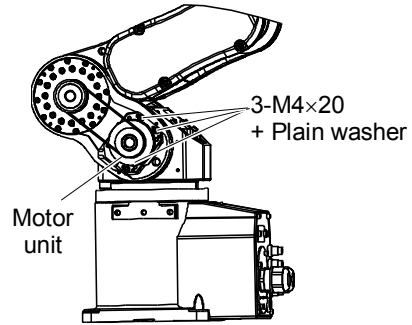

When securing loosely the motor unit, make sure the motor unit can be moved by hand, and it will not tilt when pulled. If the unit is secured too loose or too tight, the belt will not have the proper tension.

- (9) Apply the proper tension to the Joint #2 motor unit to secure it.

Mount a screw of M4x30 or longer (recommended) to the motor plate.

Pass a suitable cord or string (insulation lock) to the screw. Then, pull the cord using a force gauge or similar tool to apply the specified tension. At this point, apply tension by pressing toward the “A” surface in the figure and secure the motor unit.

Make sure to remove the screw mounted for applying tension.

Joint #2 timing belt tension: 78.4 N ± 9.8 N (8 kgf ± 1 kgf)

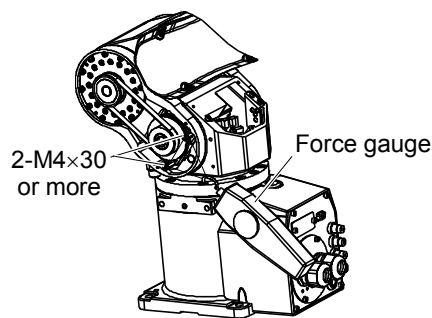
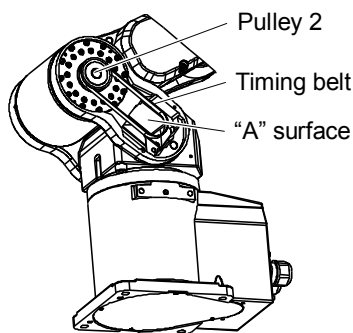

- (10) Connect the connectors.

Connectors: X121, X021, X62, BR021

- (11) Mount the Arm #1 cover and Arm #1 side cover.

For details, refer to *Maintenance: 3. Covers*.

- (12) Perform the calibration.

For details, refer to *Maintenance: 16. Calibration*.

6.2 Replacing the Reduction Gear Unit

A reduction gear unit consists of the following three parts. Also, two additional parts are included as accessories. When replacing the reduction gear unit, be sure to always replace these parts all together as one set.

Reduction gear unit: Wave generator / Flexspline (CRB combined) / Circular spline

Accessory: O-ring × 2

Refer to the *Maintenance: 17. Maintenance Parts List* for details.

We recommend replacing the O-ring (for Joint #2) with the reduction gear unit.

Maintenance Parts and Tools

	Name	Quantity	Note
Maintenance Parts	Joint #2 reduction gear	1	R13B010021
	Grease for reduction gear (SK-1A)	1	R13ZA00330100
	Joint #2 O-ring	1	R13B031242
Tools	Hexagonal wrench (width across flats: 2.5 mm)	1	For M3, M5 screws
	Hexagonal wrench (width across flats: 3 mm)	1	For M4 screw
	Force gauge	1	For belt tension
	Wiping cloth	2	For wiping grease

Removal: Joint #2 reduction gear

- (1) Remove the Arm #1 cover, Arm #1 side cover, Arm #2 side cover, and Arm #3 head cover.

For details, refer to *Maintenance: 3.Cover*

- (2) Remove the Joint #2 timing belt.

For details, refer to *Maintenance: 6.3 Replacing the Timing Belt*, Removal step (1) to (4).

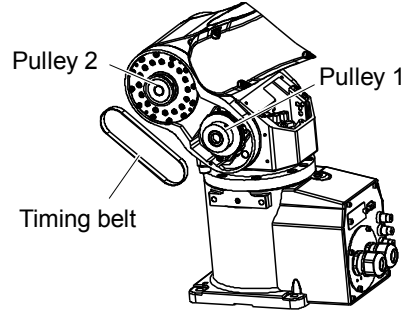

- (3) Remove the cable unit.

For details, refer to *Maintenance: 4.1 Replacing the Cable Unit*, step (6) to (17).

- (4) Turn the Manipulator laterally.

 CAUTION	<ul style="list-style-type: none"> ■ When turning the Manipulator laterally, there must be two or more people to work on it so that at least one of them can support the arm while others are removing the bolts. Removing the bolts without supporting the arm may result in the arm falling, bodily injury, and/or malfunction of the robot system.
--	--

- (5) Turn Arm #3 to opposite side and remove the Joint #2 reduction gear unit from Arm #1.

At this point, Arms #2 ~ #6 (head of #6) come free. Therefore do not work on it alone, and at least one supports the arms while others are removing the reduction gear unit.

Work on this step, wiping the grease on the parts.

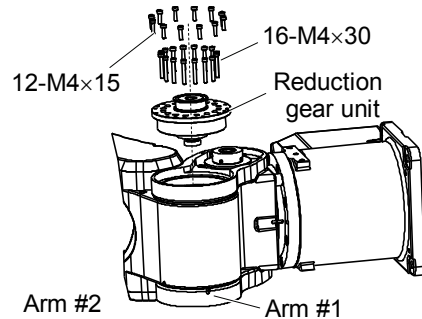

- (6) Remove the Joint #2 sleeve and sleeve flange.

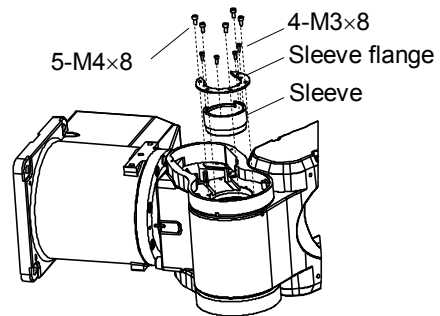

(7) Remove the parts below from Arm #2.

- Circular spline
- Flexspline
- Joint #2 O-ring
- O-ring (between reduction gear unit and circular spline)

Work on this step, wiping the grease on the parts.

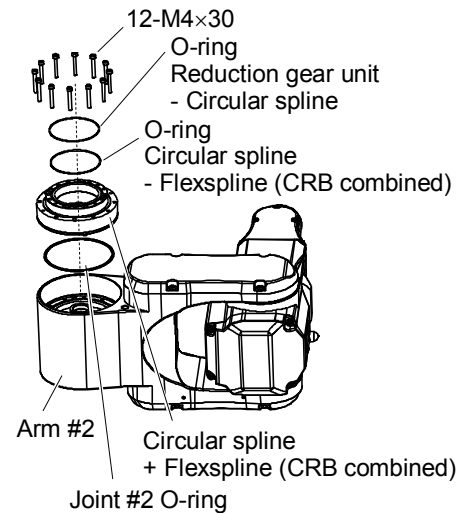

(8) Remove the wave generator from the Joint #2 reduction gear unit.

At this point, remove the bearing together. Be careful not to lose the bearing which is necessary afterward. There is a brass bushing in one of the set screws.

Be careful not to lose it.

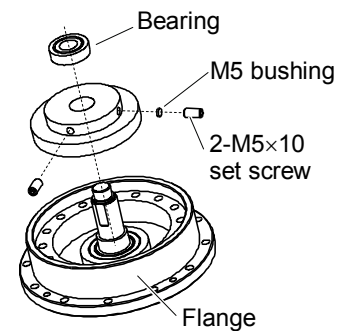

(9) Wipe the grease using a cloth or similar thing if the grease is attached to Arm #1, #2, flange, etc.

Installation: Joint #2 reduction gear

- (1) Mount the wave generator and bearing to the Joint #2 reduction gear unit.
- (2) Apply the grease (SK-1A) to the bearing area of wave generator.
- (3) Mount the Joint #2 O-ring to Arm #2.
- (4) Mount the parts below to Arm #2.
 - Flexspline (CRB combined)
 - Circular spline
 - O-ring ×2 (Accessory)

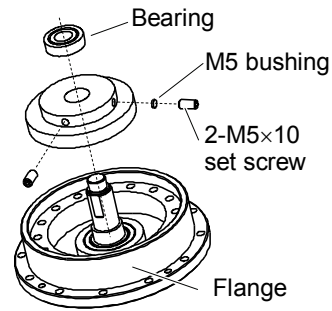

Apply the grease to fill the inside gear groove of the circular spline.

Put a O-ring to:

- Between circular spline and Flexspline (CRB combined)
- Between circular spline and Reduction gear unit

- (5) Apply the grease (SK-1A) to inside of flexspline.

Grease volume: 30 g

- (6) Mount the Joint #2 sleeve and sleeve flange.

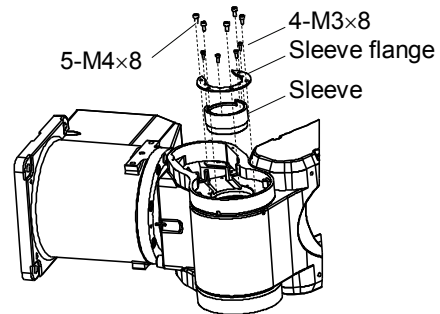

- (7) Join Arm #2 and Arm #1 and mount the Joint #2 reduction gear unit.

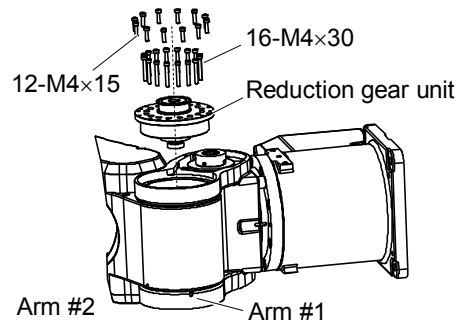

- (8) Mount the cable unit.

For details, refer to *Maintenance: 4.1 Replacing the Cable Unit*, Installation step (12) to (14).

(9) Place the Joint #2 timing belt around the Joint #2 pulley 2 and pulley 1.

(10) Apply the tension to the Joint #2 motor unit to secure.

For details, refer to *Maintenance: 6.1 Replacing the Motor*, Installation step (9) to (12).

(11) Mount the covers.

For details, refer to *Maintenance: 3. Cover*.

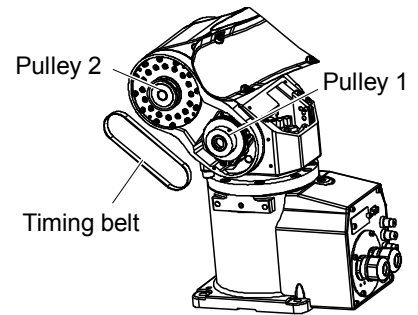

6.3 Replacing the Timing Belt

Maintenance Part and Tools

	Name	Quantity	Note
Maintenance Part	Joint #2 Timing belt	1	R13B030221
Tools	Hexagonal wrench (width across flats: 3 mm)	1	For M4 set screw
	Cloth	1	For pressing arm
	Force gauge	1	For belt tension

Removal: Joint #2 timing belt

- (1) Follow the *Maintenance: 6.1 Replacing the Motor*, Removal step (1) to (3).
- (2) Remove the Arm #1 side cover.

For details,
refer to *Maintenance: 3. Covers*.

- (3) Loosen the set screw of Joint #2 motor unit.

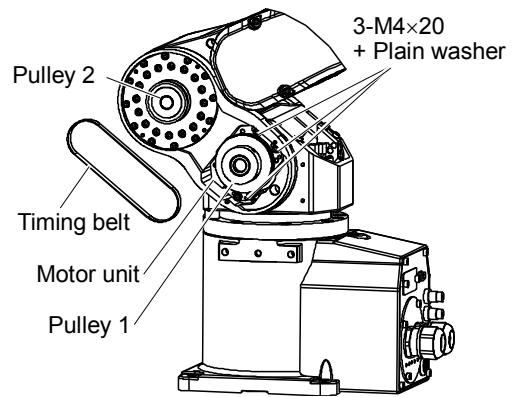

- (4) Remove the Joint #2 timing belt.

First, remove the timing belt from pulley 1 and then from the pulley 2.

Installation: Joint #2 timing belt

- (1) Place the Joint #2 timing belt around the Joint #2 pulley 1 and pulley 2.

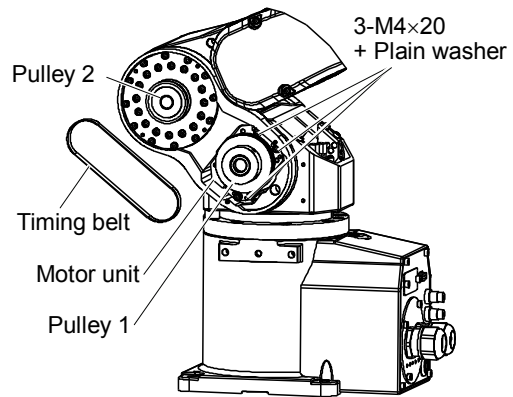

- (2) Secure the Joint #2 motor unit.

For details, refer to *Maintenance: 6.1 Replacing the Motor*, Installation step (9) to (12).

6.4 Replacing the Electromagnetic Brake

Maintenance Part and Tools

	Name	Quantity	Note
Maintenance Parts	Joint #2 electromagnetic brake	1	R13B030504
	Noise dissipative diaode	1	R13B020301
Tools	Hexagonal wrench (width across flats: 2.5 mm)	1	For M5 set screw
	Hexagonal wrench (width across flats: 3 mm)	1	For M4 screw
	Cloth	1	For pressing arm
	Force gauge	1	For belt tension

Removal: Joint #2 electromagnetic brake

Remove the Joint #2 electromagnetic brake.

For details, refer to *Maintenance: 6.1 Replacing the Motor*, Removal step (1) to (9).

Installation: Joint #2 electromagnetic brake

Assemble the Joint #2 electromagnetic brake and mount the motor unit.

For details, refer to *Maintenance: 6.1 Replacing the Motor*, Installation step (3) to (12).

7. Arm #3

 WARNING	<ul style="list-style-type: none"> ■ Before performing any replacement procedure, turn OFF the Controller and related equipment, and then pull out the power plug from the power source. Performing any replacement procedure with the power ON is extremely hazardous and may result in electric shock and/or malfunction of the robot system. ■ Do not insert or pull out the motor connectors while the power to the robot system is turned ON. Inserting or pulling out the motor connectors with the power ON is extremely hazardous and may result in serious bodily injury as the Manipulator may move abnormally, and also may result in electric shock and/or malfunction of the robot system. ■ Be sure to connect the AC power cable to a power receptacle. DO NOT connect it directly to a factory power source. To shut off power to the robot system, pull out the power plug from the power source. Performing any work while connecting the AC power cable to a factory power source is extremely hazardous and may result in electric shock and/or malfunction of the robot system.
--	---

 CAUTION	<ul style="list-style-type: none"> ■ Be careful not to apply excessive shock to the motor shaft during replacement procedures. The shock may shorten the life cycle of the motors and encoder and/or damage them. ■ Never disassemble the motor and encoder. Disassembled motor and encoder will cause a positional gap and cannot be used again.
--	---

After parts have been replaced (motors, reduction gear units, timing belts, etc.), the Manipulator cannot perform positioning properly because a mismatch exists between the origin stored in each motor encoder and its corresponding origin stored in the Controller. After replacing the parts, it is necessary to match these origins. The process of aligning the two origins is called “Calibration”. Refer to *Maintenance 13. Calibration* to perform the calibration.

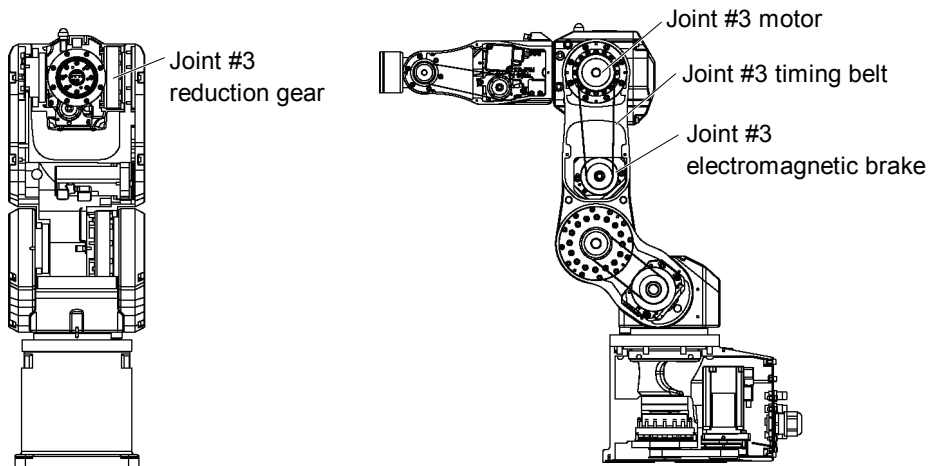

7.1 Replacing the Motor

Maintenance Parts and Tools

	Name	Quantity	Note
Maintenance Parts	AC servo motor 150W	1	R13B000618
	Noise reduction diode	1	R13B020301
Tools	Hexagonal wrench (width across flats: 2 mm)	1	For M4 set screw
	Hexagonal wrench (width across flats: 3 mm)	1	For M4 screw
	Cross-point screwdriver	1	For motor connector
	Cloth	1	For pressing arm
	Force gauge	1	For belt tension

The brake is equipped to Joint #3 to prevent the arm from lowering for its own weight while the controller power is OFF or the motor is OFF status. However, the brake does not work during replacement.

To replace the Joint #3 motor, tilt Arm #3 and press toward Arm #2. (See the step (2).)

When pressing the arm, be sure to avoid the each arm from contacting by putting a cloth or similar thing between the arms. This also protects the arm surfaces and coatings.

Removal: Joint #3 motor

- (1) Turn ON the controller power.
- (2) Tilt Arm #3.
Put a cloth between Arm #3 and Arm #2 so that two arms do not touch each other.

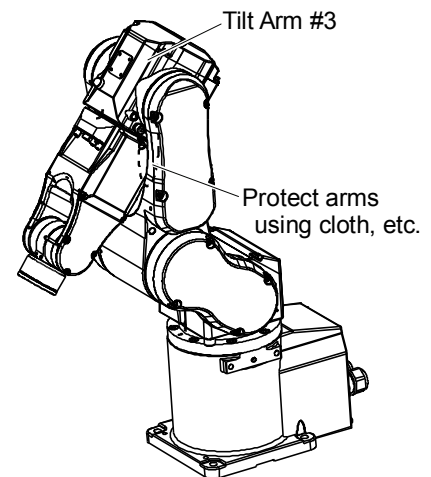

- (3) Turn OFF the controller power.
- (4) Remove the Arm #2 side cover.

For details, refer to *Maintenance: 3. Covers*.

- (5) Disconnect the connectors.
Connector: X131, X031 (Hold the claw to remove.)
Connector: BT3, BR031

- (6) Remove the Joint #3 motor unit from Arm #2.

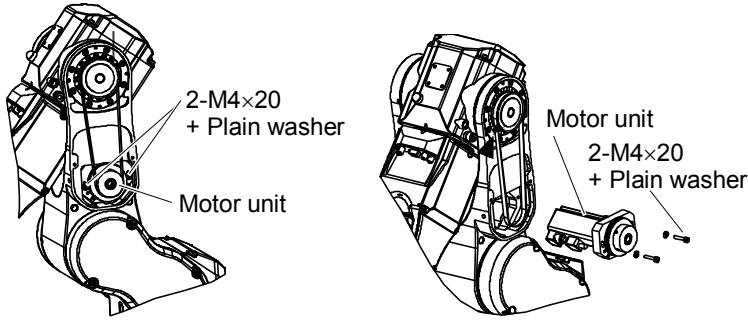

- (7) Disconnect the connector.
 Connector: BR032 (for the noise dissipative diode)

Be careful not to lose the noise dissipative diode.

- (8) Remove the Joint #3 pulley 1 and driving boss from Joint #3 motor unit.
 There is a brass bushing in one of the set screw fixing the driving boss and pulley.

Be careful not to lose it.

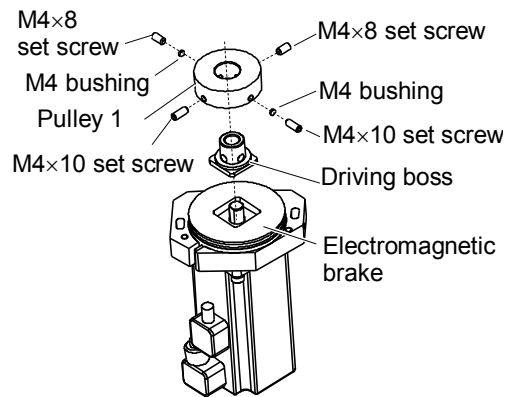

- (9) Remove the Joint #3 electromagnetic brake.

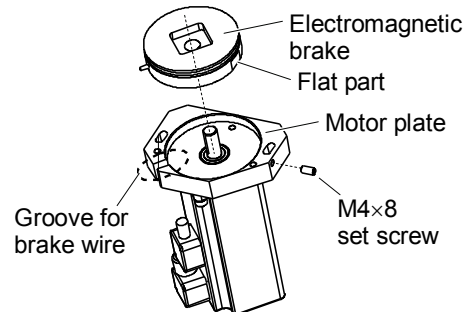

- (10) Remove the motor plate from Joint #3 motor.
 Be careful not to lose the bearing inside the motor plate.

Be careful not to lose the bearing inside the motor plate.

- (11) Remove the motor cable from the Joint #3 motor.

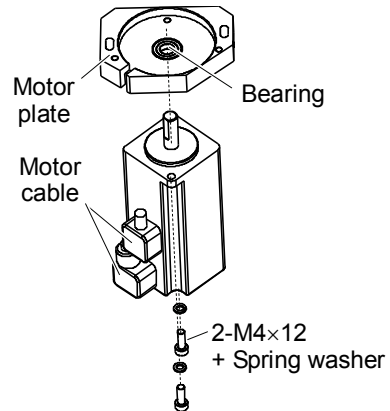

Installation : Joint #3 motor

- (1) Mount the motor cable to the Joint #3 motor.

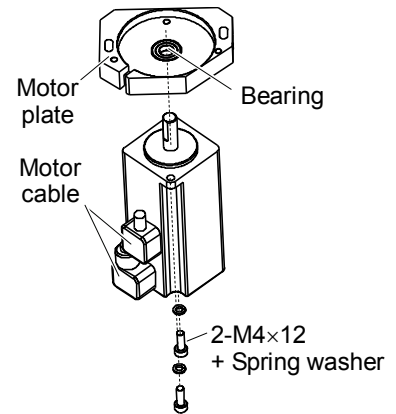

- (2) Mount the motor plate to the Joint #2 motor.3

Be careful of the direction of motor plate. (See the figure.)

- (3) Mount the Joint #3 electromagnetic brake to the Joint #3 motor unit.

Align the position of brake wire with the groove in motor plate. Then, put the flat part of brake to the side of set screw and secure the brake. Be careful not to catch the brake wire in the motor plate and cut it off.

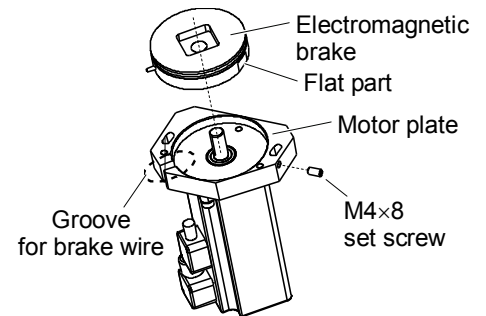

Press the brake toward the motor plate and tighten the set screw.

- (4) Mount the noise dissipative diode to the wire of electromagnetic brake.
Connector: BR032

- (5) Mount the driving boss and pulley 1 to the Joint #3 motor unit.

Align the edges of driving boss and pulley 1. Put a space of 0.5 mm between the pulley 1 and electromagnetic brake.

See the figure for the position of set screws.

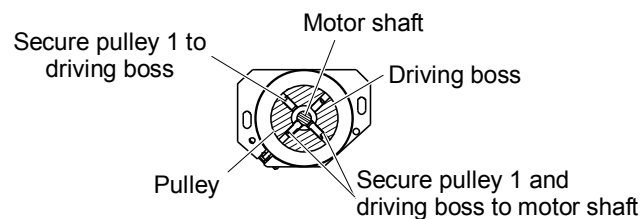
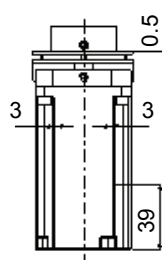
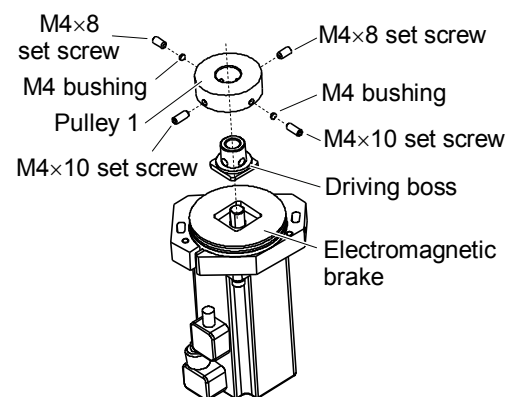

- (6) Mount the motor unit to Arm 2.

- (7) Place the Joint #3 timing belt around the Joint #3 pulley 2.

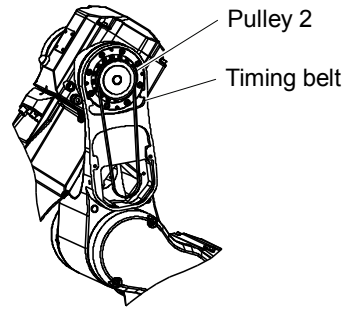

- (8) Pass the pulley 1 of Joint #3 motor unit to the Joint #3 timing belt and loosely secure it to the Arm #2.

Make sure that the gear grooves of the timing belt are fit into those of the pulley completely.

When securing loosely the motor unit, make sure the motor unit can be moved by hand, and it will not tilt when pulled. If the unit is secured too loose or too tight, the belt will not have the proper tension.

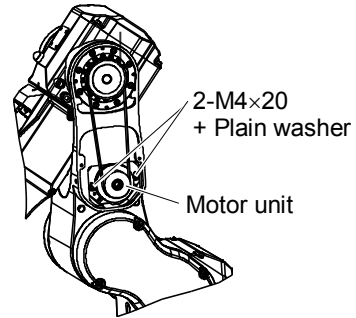

- (9) Apply the proper tension to the Joint #3 motor unit to secure it.

Mount a screw of M4 × 40 or longer (recommended) to the motor plate.

Pass a suitable cord or string (insulation lock) to the screw. Then, pull the cord using a force gauge or similar tool to apply the specified tension.

Joint #3 timing belt tension: 68.6 N ± 9.8 N (7 kgf ± 1 kgf)

Make sure to remove the screw for belt tension.

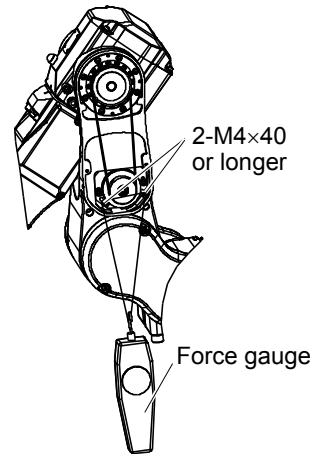

- (10) Connect the connectors.
Connectors: X131, X031, BT3, BR021
- (11) Bind the cable in the original position before removing the motor unit.
- (12) Mount the Arm #2 side cover.
For details, refer to *Maintenance: 3. Covers.*
- (13) Perform the calibration.
For details, refer to *Maintenance: 16. Calibration.*

7.2 Replacing the Reduction Gear Unit

A reduction gear unit consists of the following three parts. Also, two additional parts are included as accessories. When replacing the reduction gear unit, be sure to always replace 5 parts all together as one set.

Reduction gear unit: Wave generator / Flexspline (CRB combined) / Circular spline

Accessory: O-ring × 2

Refer to the Maintenance: 17. Maintenance Parts List for details.

We recommend replacing the O-ring (for Joint #3) with the reduction gear unit.

Maintenance Parts and Tools

	Name	Quantity	Note
Maintenance Parts	Joint #3 reduction gear	1	R13B010022
	Grease for reduction gear (SK-1A)	1	R13ZA00330100
	Joint #3 O-ring	1	R13B031243
Tools	Hexagonal wrench (width across flats: 2 mm)	1	For M4 set screws
	Hexagonal wrench (width across flats: 2.5 mm)	1	For M3 screw
	Hexagonal wrench (width across flats: 3 mm)	1	For M4 screw
	Force gauge	1	For belt tension
	Wiping cloth	2	For wiping grease

Removal: Joint #3 reduction gear

- (1) Remove the Joint #3 timing belt.

For details, refer to *Maintenance: 7.3 Joint #3 - Replacing the Timing Belt*, Removal step (1) to (3).

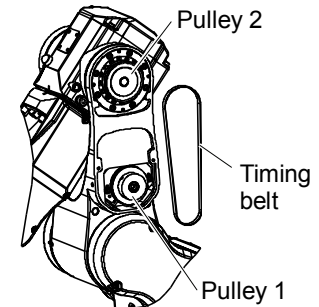

- (2) Remove the following parts:

- Arm #3 head cover
- Arm #4 cover
- User plate
- Air tube

For details, refer to *Maintenance: 3.Cover*.

- (3) Remove the cable unit.

For details, refer to *Maintenance: 4.1 Replacing the Cable Unit*, Removal step (6) to (15).

- (4) Remove the Joint #3 reduction gear unit from Arm #3.

Note that arms #3 ~ #6 (head of #6) come free when replacing the reduction gear unit. Therefore do not work on this step alone. At least one person supports the arms while others are removing the reduction gear unit.

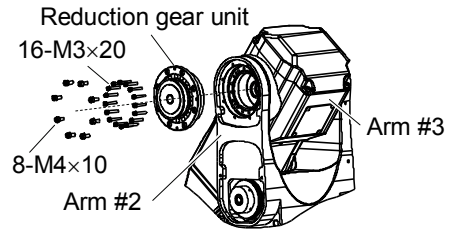

Wipe the grease from the parts while the work.

- (5) Remove the Joint #3 sleeve and sleeve flange.

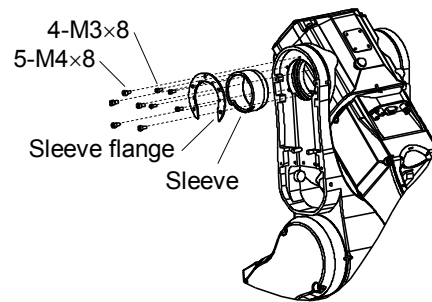

- (6) Remove the parts below from Arm #2.
 - Circular spline
 - Flexspline
 - Joint #2 O-ring
 - O-ring (between reduction gear unit and circular spline)

Wipe the grease from the parts while the work.

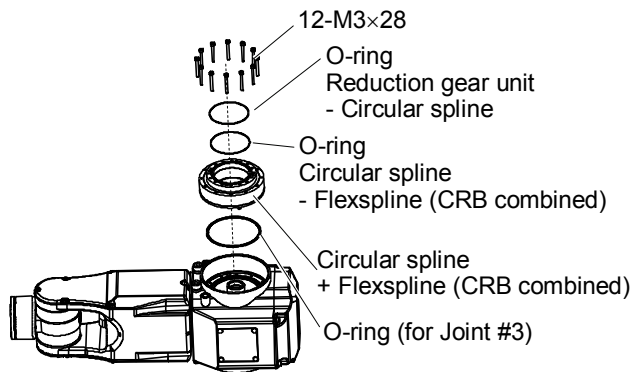

- (7) Remove the wave generator from the Joint #3 reduction gear unit.

At this point, remove the bearing together. Be careful not to lose the bearing which is necessary afterward.

There is a brass bushing in one of the set screws. Be careful not to lose it.

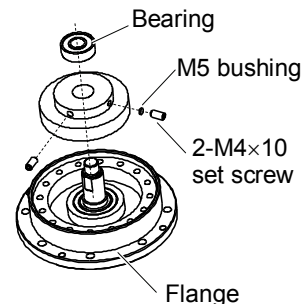

- (8) Wipe the grease using a cloth or similar thing if the grease is attached to Arm #2, Arm #3, flange, etc.

Installation: Joint #3 reduction gear

- (1) Mount the wave generator and bearing to the Joint #3 reduction gear unit.
- (2) Apply the grease (SK-1A) to the bearing area of wave generator.
- (3) Mount the Joint #3 O-ring to Arm #3.
- (4) Mount the parts below to Arm #3.
 - Circular spline
 - Flexspline (CRB combined)
 - O-ring x2 (Accessory)

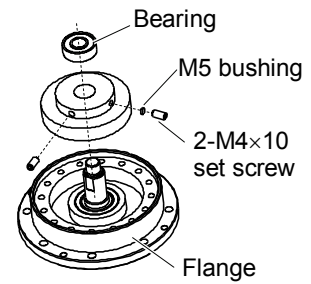

Tightening torque 2.45 N·m

Put a O-ring to:

- Between circular spline and Flexspline (CRB combined)
- Between circular spline and Reduction gear unit

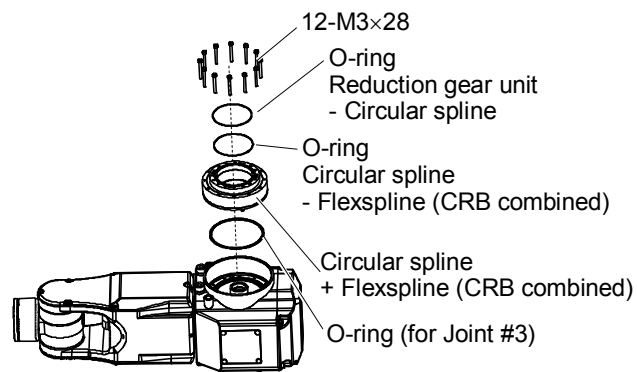

- (5) Apply the grease (SK-1A) to inside of flexspline.

Grease volume: 20 g

- (6) Mount the Joint #3 sleeve and sleeve flange.

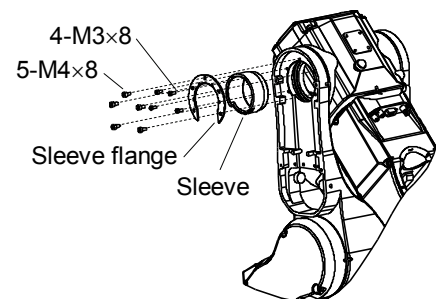

- (7) Join Arm #3 and Arm #2 and mount the Joint #3 reduction gear unit.

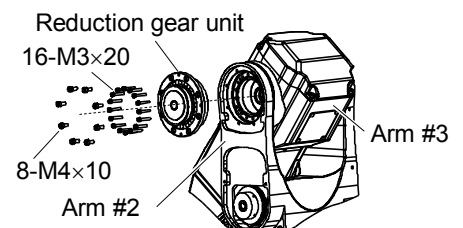

- (8) Mount the cable unit.

For details, refer to *Maintenance: 4.1 Replacing the Cable Unit*, Installation step (12) to (14).

- (9) Place the Joint #3 timing belt around the Joint #3 pulley 2 and pulley 1.

- (10) Apply the tension to the Joint #3 motor unit to secure.

For details, refer to *Maintenance: 7.1 Joint #3 – Replacing the Motor*, Installation step (8) to (11).

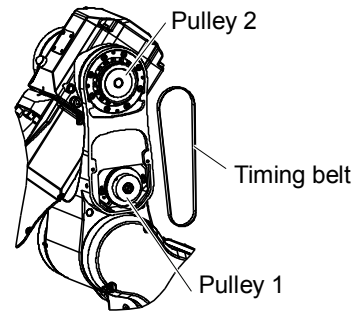

- (11) Mount the Arm #3 head cover and Arm #4 cover.

For details, refer to *Maintenance:3.Cover*

7.3 Replacing the Timing Belt

Maintenance Part and Tools

	Name	Quantity	Note
Maintenance Part	Joint #3 Timing belt	1	R13B030222
Tools	Hexagonal wrench (width across flats: 3 mm)	1	For M4 screw
	Cloth	1	For pressing arm
	Force gauge	1	For belt tension

Removal: Joint #3 Timing belt

- (1) Follow the *Maintenance: 7.1 Replacing the Motor*, Removal step (1) to (4).
- (2) Loosen the set screw of Joint #3 motor unit.
- (3) Remove the Joint #3 timing belt.

First, remove the timing belt from pulley 1 and then from the pulley 2.

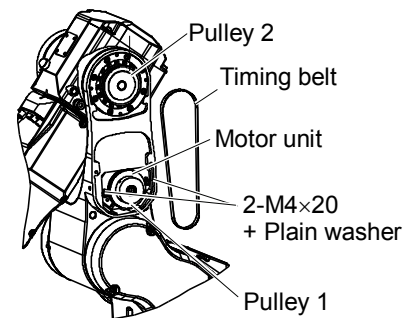

Installation: Joint #3 Timing belt

- (1) Place the Joint #3 timing belt around the Joint #3 pulley 2, and then pulley 1.
- (2) Secure the Joint #3 motor unit.

For details, refer to *Maintenance: 7.1 Replacing the Motor*, Installation step (9) to (12).

7.4 Replacing the Electromagnetic Brake

Maintenance Parts and Tools

	Name	Quantity	Note
Maintenance Parts	Joint #3 electromagnetic brake	1	R13B030505
	Noise dissipative diaode	1	R13B020301
Tools	Hexagonal wrench (width across flats: 2 mm)	1	For M4 set screw
	Hexagonal wrench (width across flats: 3 mm)	1	For M4 screw
	Cloth	1	For pressing arm
	Force gauge	1	For belt tension

Removal: Joint #3 electromagnetic brake

Remove the Joint #3 electromagnetic brake.

For details, refer to *Maintenance: 7.1 Replacing the Motor*, Removal step (1) to (9).

Installation: Joint #3 electromagnetic brake

Assemble the Joint #2 electromagnetic brake and mount the motor unit.

For details, refer to *Maintenance: 7.1 Replacing the Motor*, Installation step (3) to (11).

8. Arm #4



- Do not insert or pull out the motor connectors while the power to the robot system is turned ON. Inserting or pulling out the motor connectors with the power ON is extremely hazardous and may result in serious bodily injury as the Manipulator may move abnormally, and also may result in electric shock and/or malfunction of the robot system.
- Be sure to connect the AC power cable to a power receptacle. DO NOT connect it directly to a factory power source. To shut off power to the robot system, pull out the power plug from the power source. Performing any work while connecting the AC power cable to a factory power source is extremely hazardous and may result in electric shock and/or malfunction of the robot system.

Before performing any replacement procedure, turn OFF the Controller and related equipment, and then pull out the power plug from the power source. Performing any replacement procedure with the power ON is extremely hazardous and may result in electric shock and/or malfunction of the robot system.



- Be careful not to apply excessive shock to the motor shaft during replacement procedures. The shock may shorten the life cycle of the motors and encoder and/or damage them.
- Never disassemble the motor and encoder. A disassembled motor and encoder will cause a positional gap and cannot be used again.

After parts have been replaced (motors, reduction gear units, timing belts, etc.), the Manipulator cannot perform positioning properly because a mismatch exists between the origin stored in each motor encoder and its corresponding origin stored in the Controller. After replacing the parts, it is necessary to match these origins. The process of aligning the two origins is called “Calibration”. Refer to *Maintenance 16. Calibration* and follow the steps that pertain to the software you are using to perform the calibration.

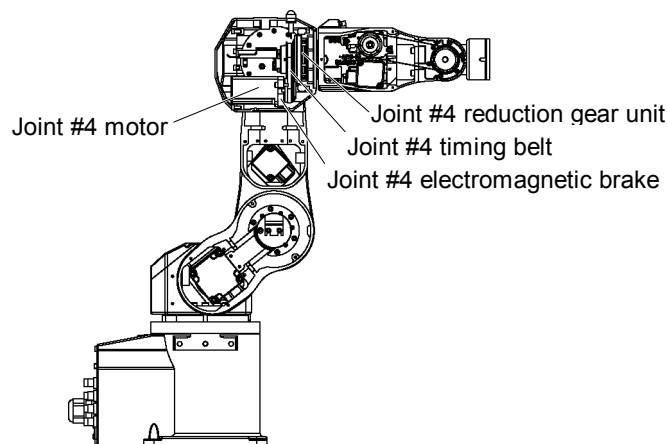

8.1 Replacing the Motor

Maintenance Parts, Tools, and Material

	Name	Qty.	Note
Maintenance Parts	AC servo motor 50W	1	R13B000619
Tools	Hexagonal wrench (width across flats: 1.5 mm)	1	For M3 set screw
	Hexagonal wrench (width across flats: 3 mm)		For M4 screw
	Flat blade screwdriver	1	For motor connector
	Force gauge	1	For belt tension

8.1.1 Joint #4 motor (without electromagnetic brake)

Removal: Joint #4 motor (without electromagnetic brake)

- (1) Turn OFF the controller power supply.
- (2) Remove the Arm #3 head cover, and Arm #3 bottom cover.
For the details, refer to Maintenance: 3. Covers.
- (3) Remove the connectors below.
Connector: X141, X041
(Hold the claw to remove.)
Connector: BT4

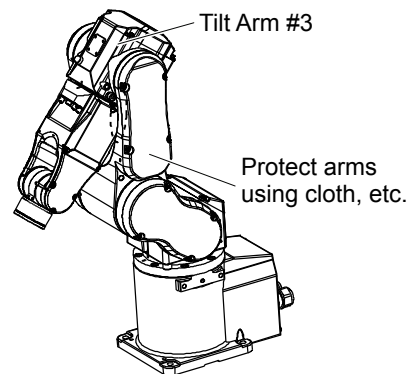

- (4) Remove the Joint #4 motor unit from Arm #3.

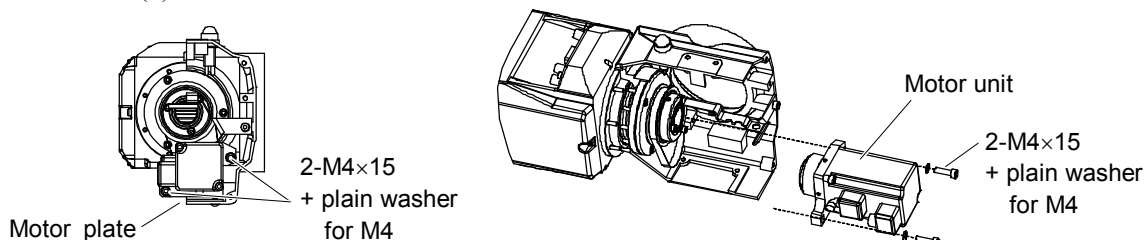

- (5) Remove the Joint #4 pulley from the Joint #4 motor unit.

There is a brass bushing in one of the set screws fixing the pulley 1.

Be careful not to lose it.

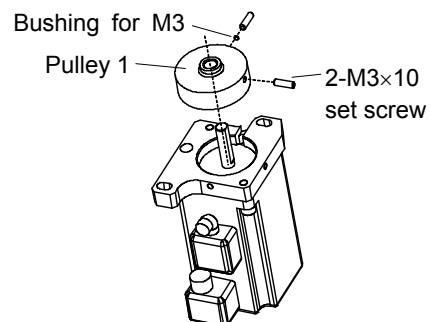

- (6) Remove the Joint #4 motor from the Joint #4 motor plate.

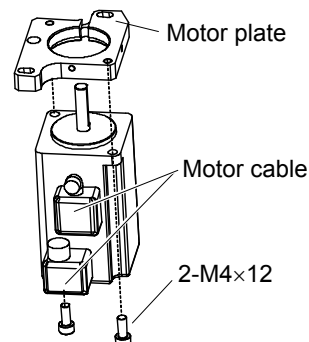

- (7) Remove the motor cable of Joint #4 motor.

Installation: Joint #4 motor (without electromagnetic brake)

- (1) Connect the motor cable to the Joint #4 motor.

- (2) Mount the motor plate to the Joint #4 motor.

The groove of motor plate must be in the side of motor opposite to the motor cable.

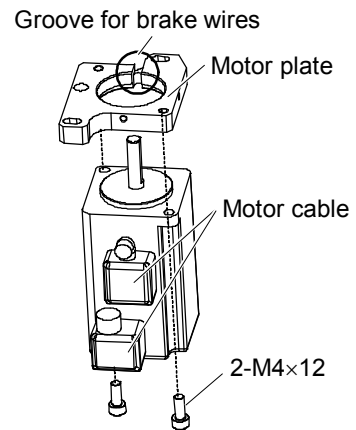

- (3) Mount the Joint #4 pulley 1 to the Joint #4 motor unit.

The space between the motor and pulley is 4mm.

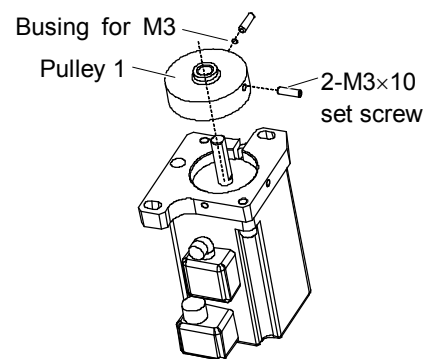
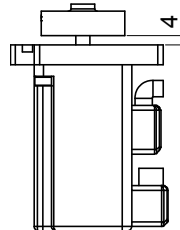

- (4) Place the Joint #4 timing belt around the Joint #4 pulley 2.

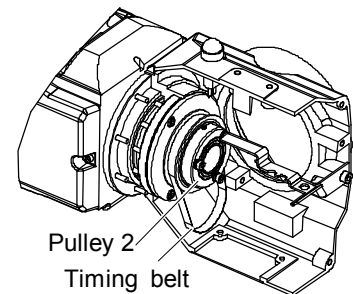

- (5) Pass the Joint #4 motor unit through the Joint #4 timing belt and loosely secure it to Arm #3.

Make sure that the gear grooves of the timing belt are fit into those of the pulley completely.

When securing loosely the motor unit, make sure the motor unit can be moved by hand, and it will not tilt when pulled. If the unit is secured too loose or too tight, the belt will not have the proper tension.

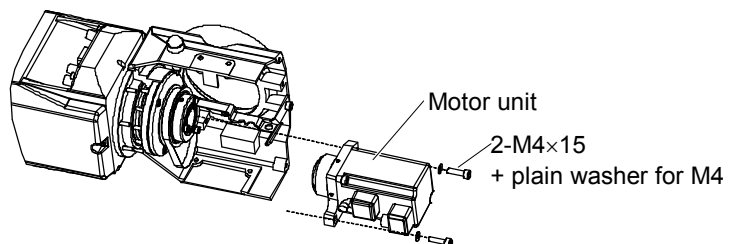

- (6) Apply the proper tension to the timing belt, and then secure the Joint #4 motor unit.

Turn ON the controller power supply and move Arm #3 to the position where you can apply the tension easily.

Turn OFF the controller power supply.

Pass a suitable cord or string (INSULOK) around the motor plate drilled hole. Then, pull the cord using a force gauge or similar tool to apply the specified tension.

At this point, press the motor cable fixing side and the other side to the “A” surface of Arm #3 and apply the tension to secure the motor unit

Joint #4 timing belt tension = $39.2\text{N} \pm 9.8\text{N}$

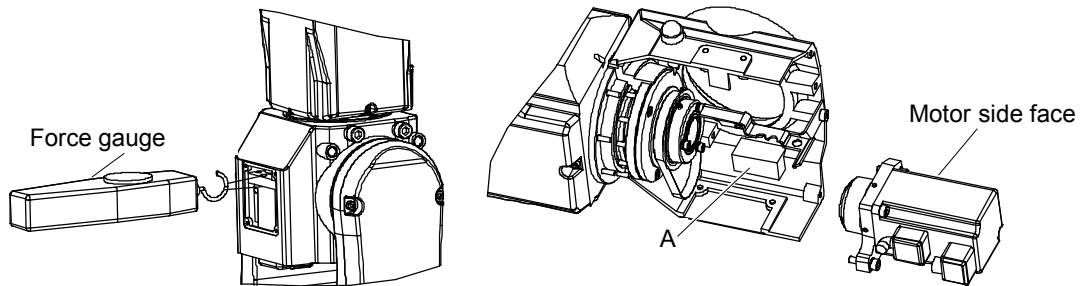

- (7) Connect the connectors: X141, X041, BT4.
- (8) Mount the Arm #3 head cover and Arm #3 bottom cover.
For details, refer to *Maintenance: 3. Covers*.
- (9) Perform the calibration for Joint #4.
For details, refer to *Maintenance: 16. Calibration*.

8.1.2 Joint #4 motor (with electromagnetic brake)

Removal: Joint #4 motor (with electromagnetic brake)

- (1) Remove the Joint #4 motor unit.

For details, refer to *Maintenance: 8.1.1 Joint #4 motor (without electromagnetic brake)*, Removal step (1) to (4).

- (2) Remove the connector BR041.

- (3) Remove the Joint #4 pulley 1 and driving boss from the Joint #4 motor unit.

There is a brass bushing in one of the set screws fixing the driving boss.

Be careful not to lose it.

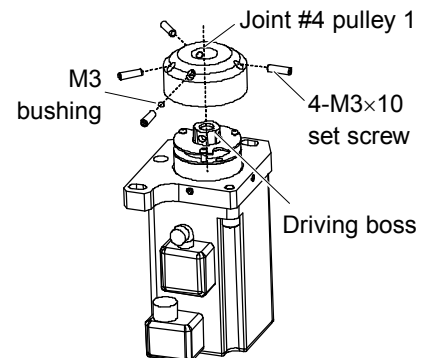

- (4) Remove the motor plate from Joint #4 motor.

Be careful of the electromagnetic brake on the motor plate.

- (5) Remove the motor cable from Joint #4 motor.

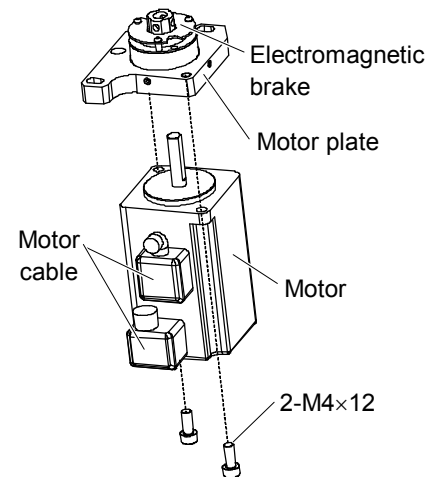

Installation: Joint #4 motor (with electromagnetic brake)

(1) Mount the motor cable to the Joint #4 motor.

(2) Mount the motor plate to the Joint #4 motor.

Be careful of the direction of motor plate installation. (See the figure on right side.)

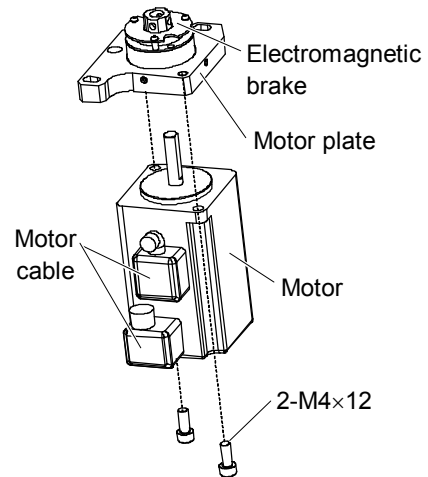

(3) Mount the driving boss to the pulley 1, and mount the driving boss and pulley 1 to the Joint #4 motor unit.

Press the pulley 1 to the very end and measure the Distance A (between the pulley 1 and motor plate).

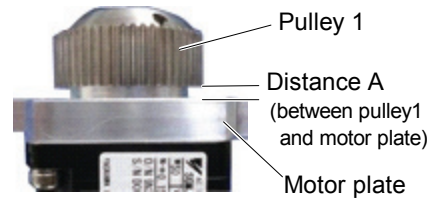

If the Distance A is less than 2.5 mm:
 Secure the pulley with the Distance A of 2.5 mm.
 If the Distance A is more than 2.5 mm:
 Secure the pulley after putting more 0.5 mm space from the position you measured the Distance A.

See the figure for the position of set screws.

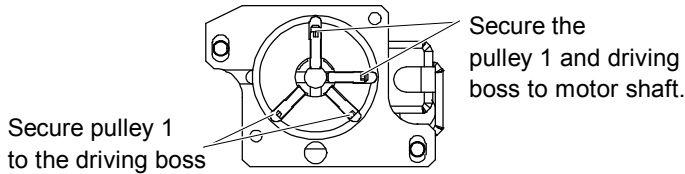
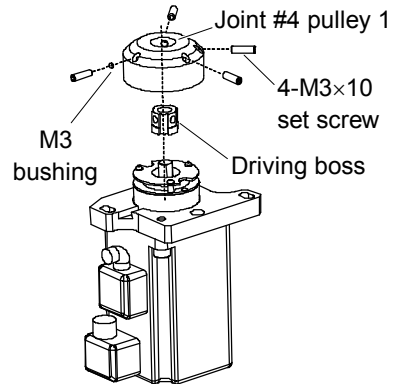

(4) Place the Joint #4 timing belt around the Joint #4 pulley 2.

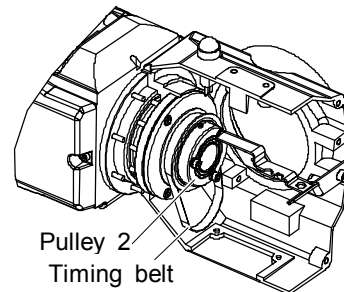

- (5) Pass the pulley 1 of Joint #4 motor unit through the Joint #4 timing belt and loosely secure it to Arm #3.

Make sure that the gear grooves of the timing belt are fit into those of the pulley completely.

When securing loosely the motor unit, make sure the motor unit can be moved by hand, and it will not tilt when pulled. If the unit is secured too loose or too tight, the belt will not have the proper tension.

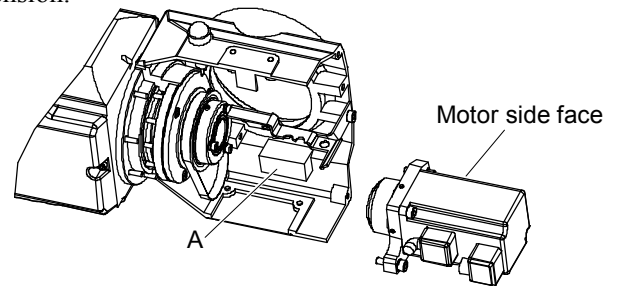

- (6) Apply the proper tension to the Joint #4 motor unit, and then secure the unit by pressing to the motor side face and “A” surface.

Pass a suitable cord or string (INSULOK) around the motor plate drilled hole. Then, pull the cord using a force gauge or similar tool to apply the specified tension.

Belt tension: $39.2\text{N} \pm 9.8\text{N}$ (4 kgf \pm 1 kgf)

- (7) Connect the connectors: X141, X041, BT4, BR041.
- (8) Mount the Arm #3 head cover and Arm #3 bottom cover.
For details, refer to *Maintenance: 3. Covers*.
- (9) Perform the calibration.
For details, refer to *Maintenance: 16. Calibration*.

8.2 Replacing the Reduction Gear Unit

After parts have been replaced (motors, reduction gear units, timing belts, etc.), the Manipulator cannot perform positioning properly because a mismatch exists between the origin stored in each motor encoder and its corresponding origin stored in the Controller. After replacing the parts, it is necessary to match these origins. The process of aligning the two origins is called “Calibration”. Refer to Maintenance 16. Calibration and follow the steps that pertain to the software you are using to perform the calibration.

8.2.1 Structure of Reduction Gear Unit

A reduction gear unit consists of the waveform generator, flexspline, and circular spline. When replacing the reduction gear unit, be sure to always replace these parts all together as one set.

For details, refer to *Maintenance: 17. Maintenance Parts List*.

We recommend replacing the O-ring (for Joint #4) together with reduction gear unit.

8.2.2 How to Grease the Reduction Gear Unit

 CAUTION	<ul style="list-style-type: none"> ■ Wear protective gear including a mask, protective goggles, and oil-resistant gloves during grease up. If grease gets into your eyes, mouth, or on your skin, follow the instructions below. <ul style="list-style-type: none"> If grease gets into your eyes : Flush them thoroughly with clean water, and then see a doctor immediately. If grease gets into your mouth : If swallowed, do not induce vomiting. See a doctor immediately. <li style="padding-left: 40px;">If grease just gets into your mouth, wash out your mouth with water thoroughly. If grease gets on your skin : Wash the area thoroughly with soap and water.
--	---

When greasing the reduction gear unit, use only the grease specified for the reduction gear unit. While greasing the reduction gear units, be careful not to allow any foreign substances in the grease. The adequate quantities of grease are specified as follows:

8.2.3 How to Replace the Reduction Gear Unit

Maintenance Parts, Tools, and Material

	Name	Quantity	Note
Maintenance Parts	Joint #4 reduction gear	1	R13B010023
	Grease for reduction gear (SK-1A)	1	R13ZA00330100
	O-ring	1	R13B031244
Tools	Hexagonal wrench (width across flats: 1.5 mm)	1	For M3 set screw
	Hexagonal wrench (width across flats: 2.5 mm)	1	For M3 screw
	Hexagonal wrench (width across flats: 3 mm)	1	For M4 screw
	Force gauge	1	For belt tension
	Sharpening stone	1	For repaing removal tap
	Wiping cloth	1	For wiping liquid gasket For wiping adhesive

Removal: Joint #4 reduction gear

- (1) Remove the Joint #4 motor unit from Arm #3.

For details, refer to Maintenance: 8.1.1 Joint #4 motor (without electromagnetic brake), Removal step (2) to (4).

The removal step of Joint #4 motor unit is common to the model that has brakes on all axes.

Remove the cable unit.

- (2) Remove the Joint #4 cable fixing plate. (2-M4×5)
- (3) Remove the Joint #4 timing belt.

- (4) Remove the Joint #4 fittings.

- (5) Remove the LED lamp.

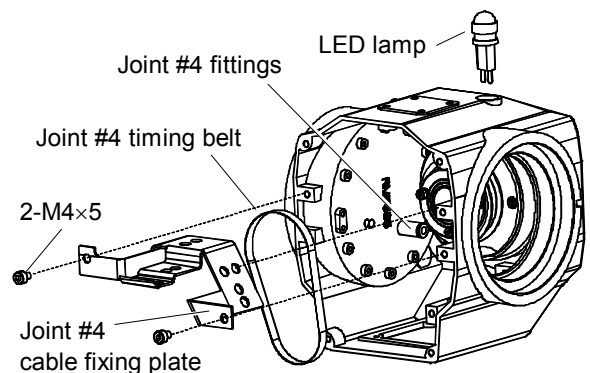

- (6) Remove the Joint #4 output pulley. (2-M3×8 set screw, with bushing.)

When removing the Joint #4 output pulley, also remove the bearing.

(3-M3×6 + flat head screw for M3 + washer for M3)

Be careful not to lose the bearing which is necessary afterward.

There is a brass bushing in one of the set screws. Be careful not to lose it.

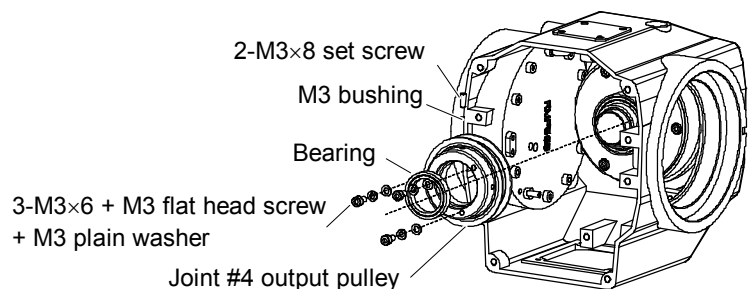

- (7) Remove the Joint #4 reduction gear flange (3-M3×8).
When removing the flange, remove the two bearings and metal together.
Be careful not to lose metal seal which is necessary afterward.

When removing parts, the grease is attached to the Joint #4 reduction gear flange, etc. Wipe the grease during the replacement.

- (8) Remove the wave generator from the Joint #4 reduction gear unit.

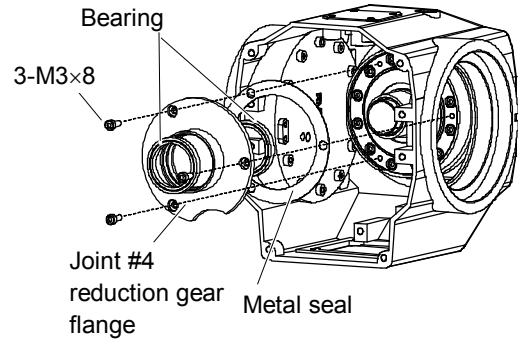

- (9) Remove the circular spline. (12-M3×10, removal tap 3-M3)
If you have any crack while using a removal tap, repair using a sharpening stone.
- (10) Remove the flexspline. (12-M3×10)
- (11) Remove the O-ring.
- (12) Wipe the grease using a cloth if any attaches to Arm #4, etc.
- (13) Wipe the grease using a cloth if any attaches to Arm #4, etc.

Installation: Joint #4 reduction gear

NOTE



When tightening the bolts, please check and double check the every bolt is surely tightened.

- (1) Apply the grease (SK-1A) to the both sides of gear of flexspline and circular spline and wave generator (to the level that it covers the ball bearing.)
- (2) Mount the O-ring to Arm #4.
- (3) Turn the face of circular spline (stamp) to the front and mount it to Arm #4.
 12-M3×10 Tightening torque: 2.45 N·m
 Be careful of the mounting angle of the M3 screw hole which affects the angle of mounting the Joint #4 reduction gear flange. (See the figure below.)
- (4) Mount the flexspline. (12-M3×10)
 Make sure that the cable sleeve is attached while mounting the flexspline for the centering.

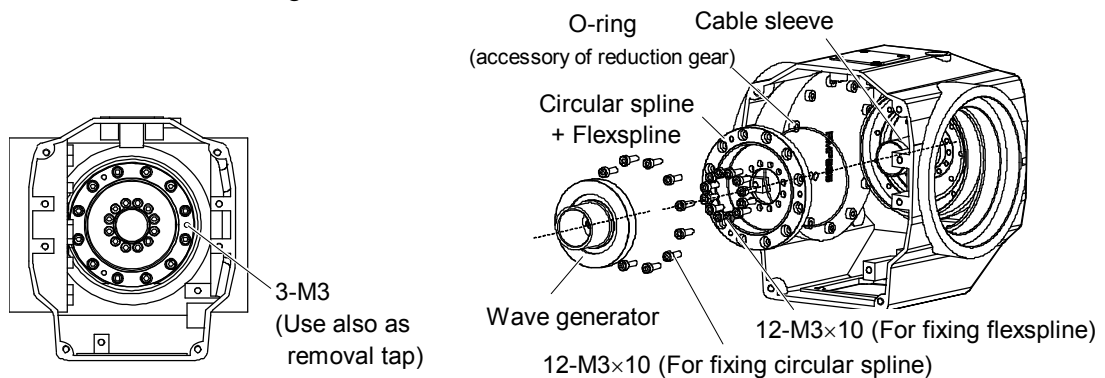

- (5) Apply the grease to inside of flexspline (SK-1A).

Grease volume: 10 g

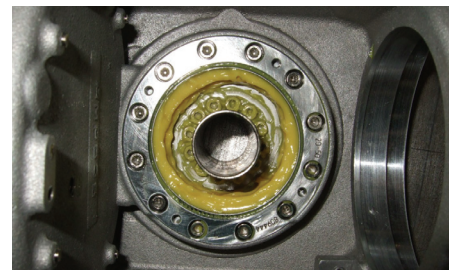

- (6) Mount the veering to the wave generator. Mount it to the flexspline.
- (7) Mount the metal seal.
- (8) Mount the bearing to the Joint #4 reduction gear flange and loosely secure it to circular spline. (3-M3×8)
 Be careful of the direction of cutout in the Joint #4 reduction gear flange.

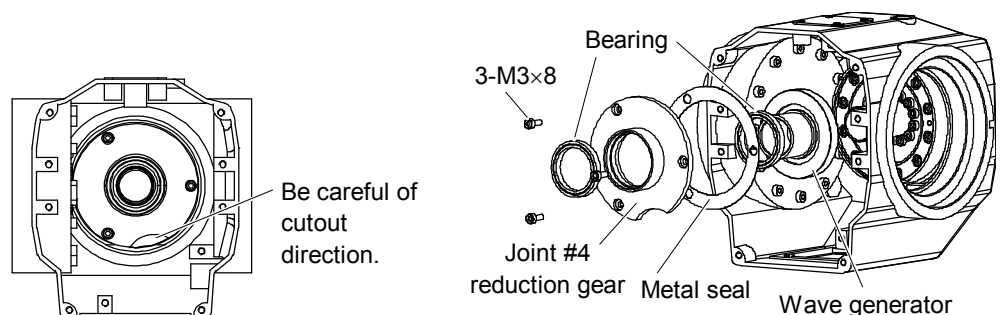

(9) Mount the Joint #4 output pulley. (2-M3×8 set screw, with bushing)

(10) Mount the bearing. (3-M3×6 + Disk spring for M3 + Plain washer for M3)

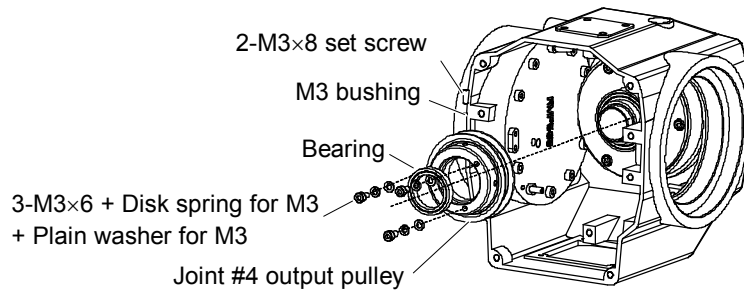

(11) Tighten three set screws of Joint #4 reduction gear flange.

(12) Mount the Joint #3 reduction gear unit.

For details, refer to *Maintenance: 7.2 Joint #3 - Replacing the Reduction Gear Unit*, Installation step (6) to (10).

(13) Mount the LED lamp.

(14) Mount the Joint #4 fittings.

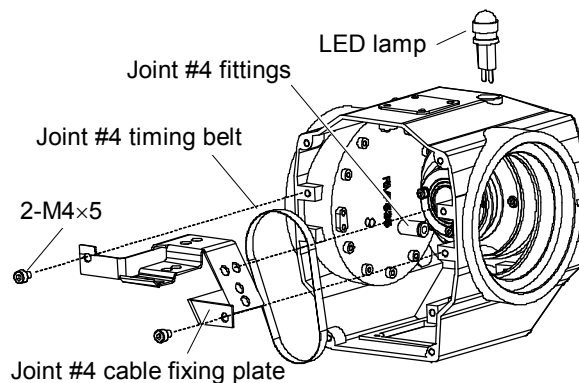

(15) Mount the Joint #4 motor unit.

Without electromagnetic brake:

For details, refer to *Maintenance: 8.1.1 Joint #4 motor (without electromagnetic brake)*, Installation step (4) to (8).

For the model with brakes on all axes:

For details, refer to *Maintenance: 8.1.2 Joint #4 motor (with electromagnetic brake)*, Installation step (4) to (8).

(16) Perform the calibration for Joint #4.

For details, refer to *Maintenance: 16. Calibration*.

8.3 Replacing the Timing Belt

Maintenance Part and Tools

	Name	Quantity	Note
Maintenance Part	Joint #4 Timing belt	1	R13B030223
Tools	Hexagonal wrench (width across flats: 3 mm)	1	For M4 set screw
	Force gauge	1	For belt tension

Removal: Joint #4 Timing belt

- (1) Remove the Joint #4 motor unit.

For details, refer to *Maintenance 8.1.1 Joint #4 motor (without electromagnetic brake)*, Removal step (1) to (4).

- (2) Remove the Joint #4 timing belt.

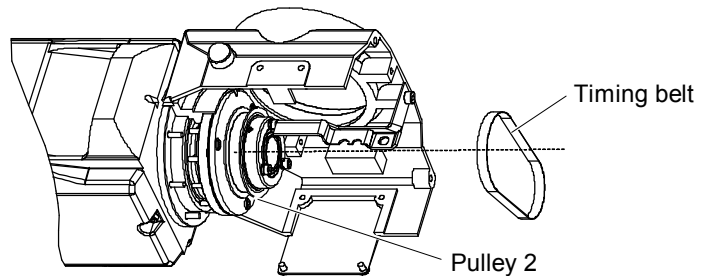

Installation: Joint #4 Timing belt

- (1) Place the Joint #4 timing belt around the Joint #4 pulley 2.
- (2) Mount the Joint #4 motor unit.

For details, refer to *Maintenance 8.1.1 Joint #4 motor (without electromagnetic brake)*, Installation step (5) to (9).

8.4 Replacing the Electromagnetic Brake

Maintenance Part and Tools

	Name	Quantity	Note
Maintenance Parts	Joint #4 Electromagnetic brake	1	R13B030506
Tools	Hexagonal wrench (width across flats: 1.5 mm)	1	For M3 set screw
	Hexagonal wrench (width across flats: 3 mm)	1	For M4 screw
	Force gauge	1	For belt tension

Removal: Joint #4 Electromagnetic brake

- (1) Follow the steps in *Maintenance 8.1.2 Joint #4 motor (with electromagnetic brake)*, Removal step (1) to (2).
- (2) Remove the Joint #4 electromagnetic brake from Joint #4 motor unit.

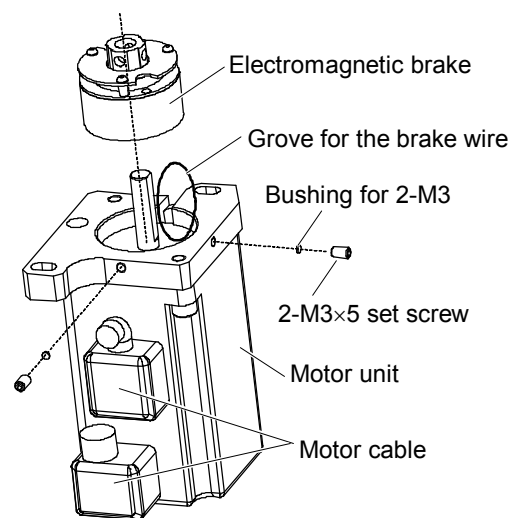

Installation: Joint #4 Electromagnetic brake

- (1) Mount the Joint #4 electromagnetic brake to the Joint #4 motor unit.

Align the positions of electromagnetic brake wire and groove of motor plate. Then, press the electromagnetic brake to the very end and secure it.

Tightening torque M3: 0.7 N·m

- (2) Assemble the motor unit and mount it.

For details, refer to *Maintenance 8.1.2 Joint #4 motor (with electromagnetic brake)*, Installation step (3) to (9).

9. Arm #5



- Before performing any replacement procedure, turn OFF the Controller and related equipment, and then pull out the power plug from the power source. Performing any replacement procedure with the power ON is extremely hazardous and may result in electric shock and/or malfunction of the robot system.
- Do not insert or pull out the motor connectors while the power to the robot system is turned ON. Inserting or pulling out the motor connectors with the power ON is extremely hazardous and may result in serious bodily injury as the Manipulator may move abnormally, and also may result in electric shock and/or malfunction of the robot system.
- Be sure to connect the AC power cable to a power receptacle. DO NOT connect it directly to a factory power source. To shut off power to the robot system, pull out the power plug from the power source. Performing any work while connecting the AC power cable to a factory power source is extremely hazardous and may result in electric shock and/or malfunction of the robot system.



- Be careful not to apply excessive shock to the motor shaft during replacement procedures. The shock may shorten the life cycle of the motors and encoder and/or damage them.
- Never disassemble the motor and encoder. A disassembled motor and encoder will cause a positional gap and cannot be used again.

After parts have been replaced (motors, reduction gear units, timing belts, etc.), the Manipulator cannot perform positioning properly because a mismatch exists between the origin stored in each motor encoder and its corresponding origin stored in the Controller. After replacing the parts, it is necessary to match these origins. The process of aligning the two origins is called “Calibration”. Refer to *Maintenance 16. Calibration* to perform the calibration.

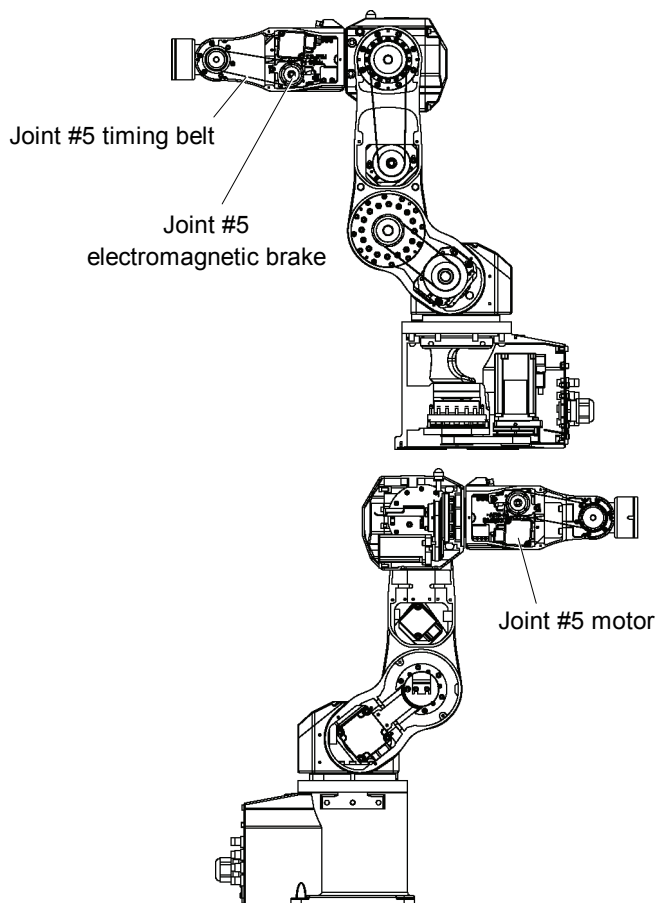

9.1 Replacing the Motor

Maintenance Part and Tools

	Name	Quantity	Note
Maintenance Part	AC servo motor 50W	1	R13B000620
Tools	Hexagonal wrench (width across flats: 1.5 mm)	1	For M3 set screw
	Hexagonal wrench (width across flats: 2.5 mm)	1	For M3 screw
	Hexagonal wrench (width across flats: 3 mm)	1	For M4 screw
	Cross-point screwdriver	1	For motor connector
	Force gauge	1	For belt tension

The brake is equipped to Joint #5 to prevent the arm from lowering for its own weight while the controller power is OFF or the motor is OFF status. However, the brake does not work during replacement.

The following is steps of the motor replacement. Use the original motor cables (power cable, signal cable).

When replacing the motor cables, pull them out from Arm #3 cylinder.

For details, refer to *Maintenance: 4.1 Replacing the Cable Unit*.

Removal: Joint #5 motor

- (1) Turn ON the controller power.
- (2) Remove the Arm #4 side cover.

For details, refer to *Maintenance: 3. Covers*.

- (3) Remove the Joint #5 motor unit from Arm #4.

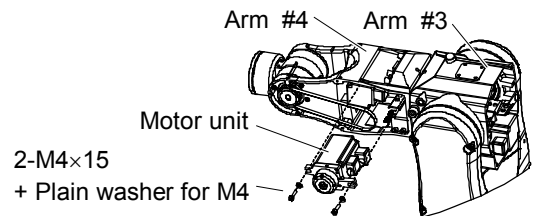

- (4) Remove the motor cable from Joint #5 motor.
* With the brake, keep the brake cable connected.

- (5) Remove the Joint #5 pulley 1 and driving boss from Joint #5 motor unit.

There is a brass bushing in one of the set screw fixing the pulley 1 and motor shaft.

Be careful not to lose it.

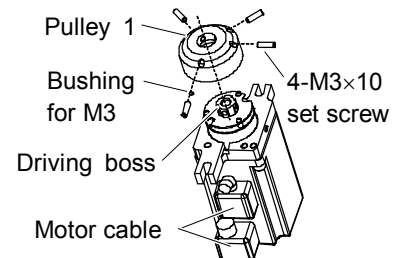

- (6) Remove the motor plate from Joint #5 motor.

Be careful of the electromagnetic brake on the motor plate.

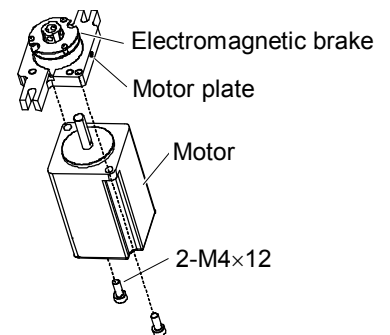

Installation: Joint #5 motor

- (1) Mount the motor cable to the Joint #5 motor.
- (2) Mount the motor plate to the Joint #5 motor.

Be careful of the direction of motor plate.

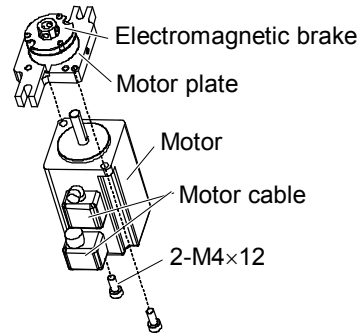

- (3) Mount the driving boss to the pulley 1, and mount the driving boss and pulley 1 to the Joint #5 motor shaft. Press the pulley 1 to the very end and measure the Distance A (between the pulley 1 and motor plate).

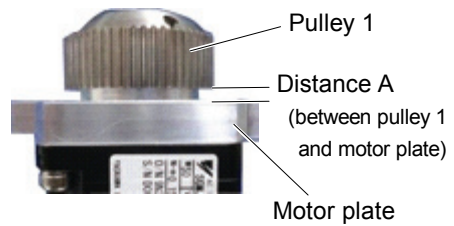

If the Distance A is less than 2.5 mm:
Secure the pulley with the Distance A of 2.5 mm.

If the Distance A is more than 2.5 mm:
Secure the pulley after putting more 0.5 mm space from the position you measured the Distance A.

See the figure for the position of set screws.

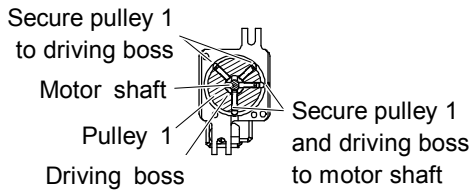
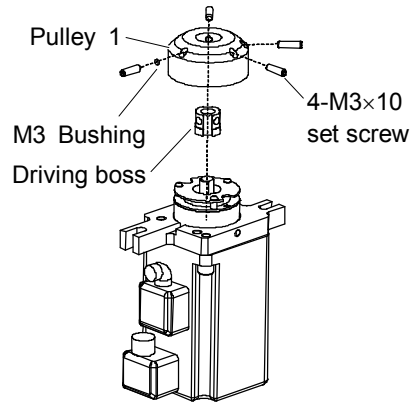

- (4) Insert the Joint #5 motor into Arm #4.
*Be careful not to scratch or catch cable.
- (5) Place the Joint #5 timing belt around the Joint #5 pulley 2.

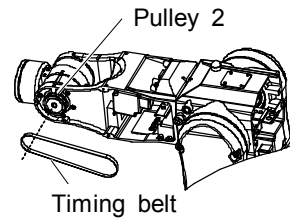

- (6) Pass the pulley 1 of Joint #5 motor unit to the Joint #5 timing belt and loosely secure it to the Arm #4.

Make sure that the gear grooves of the timing belt are fit into those of the pulley completely.

When securing loosely the motor unit, make sure the motor unit can be moved by hand, and it will not tilt when pulled. If the unit is secured too loose or too tight, the belt will not have the proper tension.

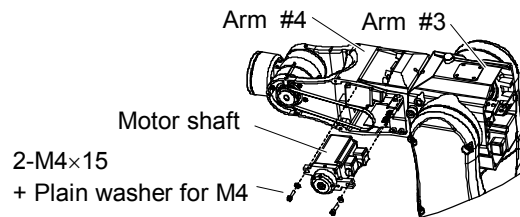

- (7) Apply the proper tension to the Joint #5 motor unit to secure it.

Mount a screw of M4x40 or longer (recommended) to the motor plate.

Pass a suitable cord or string (insulation lock) to the screw. Then, pull the cord using a force gauge or similar tool to apply the specified tension.

Make sure to remove the screw mounted for applying tension.

Joint #5 timing belt tension: $39.2 \text{ N} \pm 9.8 \text{ N}$ ($4 \text{ kgf} \pm 1 \text{ kgf}$)

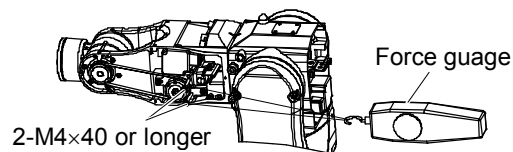

- (8) Mount the Arm #4 side cover.

For details, refer to *Maintenance: 3. Covers*.

- (9) Perform the calibration.

For details, refer to *Maintenance: 16. Calibration*.

9.2 Replacing the Timing Belt

Maintenance Parts and Tools

	Name	Quantity	Note
Maintenance Part	Joint #5 Timing belt	1	R13B030224
Tools	Hexagonal wrench (width across flats: 2.5 mm)	1	For M3 screw
	Hexagonal wrench (width across flats: 3 mm)	1	For M4 screw
	Force gauge	1	For belt tension

Removal: Joint #5 Timing belt

- (1) Turn ON the controller power.
- (2) Remove the Arm #4 side cover.
For details, refer to *Maintenance: 3. Covers*.
- (3) Loosen the set screw of Joint #5 motor unit.

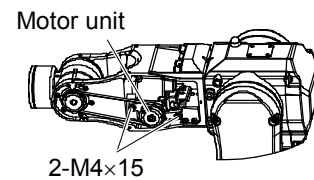

- (4) Remove the Joint #5 timing belt.

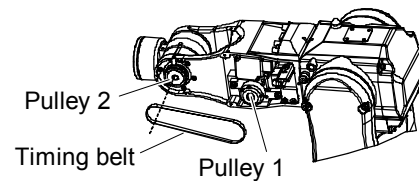

Installation Joint #5 Timing belt

- (1) Place the Joint #5 timing belt around the Joint #5 pulley 1 and pulley 2.
- (2) Secure the Joint #5 motor unit.

For details, refer to *Maintenance: 9.1 Joint #5 – Replacing the Motor*, Installation step (6) to (10).

9.3 Replacing the Electromagnetic Brake

Maintenance Part and Tools

	Name	Quantity	Note
Maintenance Parts	Joint #5 electromagnetic brake	1	R13B030506
Tools	Hexagonal wrench (width across flats: 1.5 mm)	1	For M3 set screw
	Hexagonal wrench (width across flats: 2.5 mm)	1	For M3 screw
	Hexagonal wrench (width across flats: 3 mm)	1	For M4 screw
	Force gauge	1	For belt tension

Removal: Joint #5 electromagnetic brake

- Follow the *Maintenance: 9.1 Joint #5 – Replacing the Motor*, Removal step (1) to (6).
- Remove the Joint #5 electromagnetic brake from the Joint #5 motor unit.

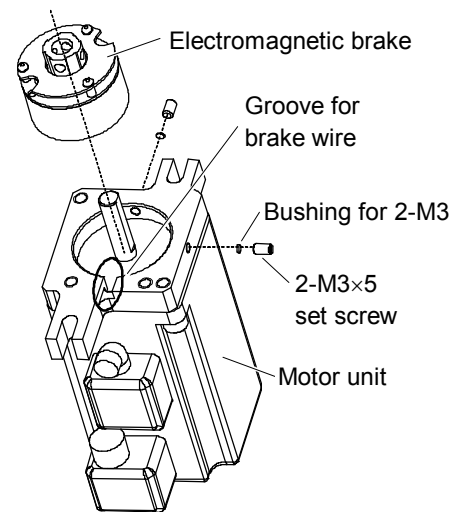

Installation: Joint #5 electromagnetic brake

- Mount the Joint #5 electromagnetic brake to the Joint #5 motor unit.

Align the wire of electromagnetic brake and the groove of motor plate.

Press the electromagnetic brake into the very end and secure it.

Tightening torque M3: 0.7 N·m

- Assemble and mount the motor unit.

For details, refer to *Maintenance: 9.1 Joint #5 – Replacing the Motor*, Installation step (3) to (10).

10. Arm #6

 WARNING	<ul style="list-style-type: none"> ■ Before performing any replacement procedure, turn OFF the Controller and related equipment, and then pull out the power plug from the power source. Performing any replacement procedure with the power ON is extremely hazardous and may result in electric shock and/or malfunction of the robot system. ■ Do not insert or pull out the motor connectors while the power to the robot system is turned ON. Inserting or pulling out the motor connectors with the power ON is extremely hazardous and may result in serious bodily injury as the Manipulator may move abnormally, and also may result in electric shock and/or malfunction of the robot system. ■ Be sure to connect the AC power cable to a power receptacle. DO NOT connect it directly to a factory power source. To shut off power to the robot system, pull out the power plug from the power source. Performing any work while connecting the AC power cable to a factory power source is extremely hazardous and may result in electric shock and/or malfunction of the robot system.
--	---

 CAUTION	<ul style="list-style-type: none"> ■ Be careful not to apply excessive shock to the motor shaft during replacement procedures. The shock may shorten the life cycle of the motors and encoder and/or damage them. ■ Never disassemble the motor and encoder. A disassembled motor and encoder will cause a positional gap and cannot be used again.
--	---

After parts have been replaced (motors, reduction gear units, timing belts, etc.), the Manipulator cannot perform positioning properly because a mismatch exists between the origin stored in each motor encoder and its corresponding origin stored in the Controller. After replacing the parts, it is necessary to match these origins. The process of aligning the two origins is called “Calibration”. Refer to *Maintenance 16. Calibration* and follow the steps that pertain to the software you are using to perform the calibration.

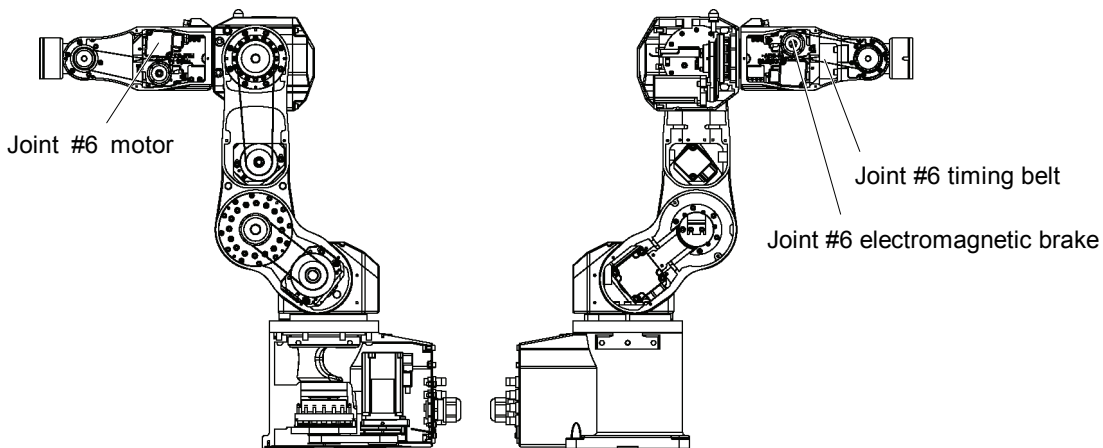

10.1 Replacing the Motor

Maintenance Part and Tools

	Name	Quantity	Note
Maintenance Part	AC servo motor 50W	1	R13B000620
Tools	Hexagonal wrench (width across flats: 1.5 mm)	1	For M3 set screw
	Hexagonal wrench (width across flats: 2.5 mm)	1	For M3 screw
	Hexagonal wrench (width across flats: 3 mm)	1	For M4 screw
	Cross-point screwdriver	1	For motor connector
	Force gauge	1	For belt tension

The brake is equipped to Joint #6 to prevent the arm from lowering for its own weight while the controller power is OFF or the motor is OFF status. However, the brake does not work during replacement.

The following is steps of the motor replacement. Use the original motor cables (power cable, signal cable).

When replacing the motor cables, pull them out from Arm #3 cylinder.

For details, refer to *Maintenance: 4.1 Replacing the Cable Unit*.

10.1.1 Joint #6 motor (without electromagnetic brake)

Removal: Joint #6 motor (without electromagnetic brake)

- (1) Turn OFF the controller power supply.
- (2) Remove the Arm #4 side cover.

For the details, refer to *Maintenance: 3. Covers.*

- (3) Remove the Joint #6 motor unit from Arm #4.

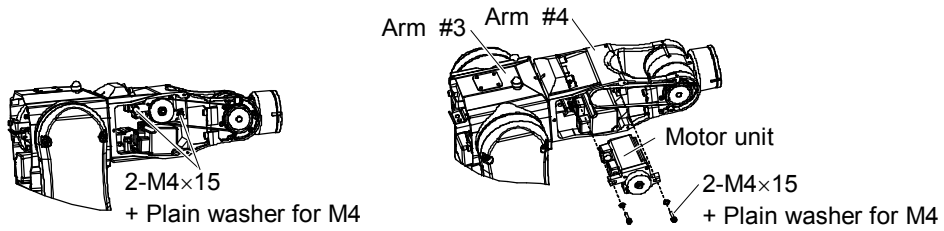

- (4) Remove the motor cable from the Joint #5 motor.
* With the brake, keep the brake cable connected.

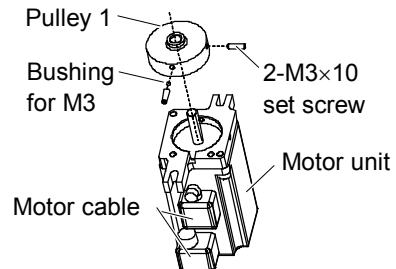

- (5) Remove the pulley 1 of Joint #6 from the Joint #6 motor unit.

- (6) Remove the motor plate from the Joint #4 motor.

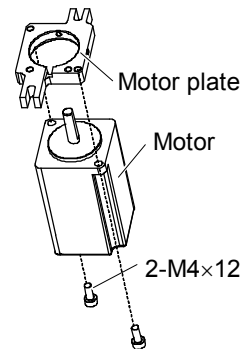

Installation: Joint #6 motor (without electromagnetic brake)

- (1) Connect the motor cable to the Joint #6 motor.
- (2) Mount the motor plate to the Joint #6 motor.
Be careful of the direction of motor plate.
(See figure on right side.)

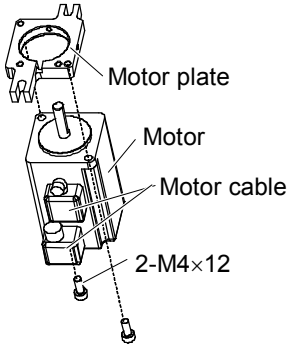

- (3) Mount the pulley 1 to the Joint #6 motor unit.

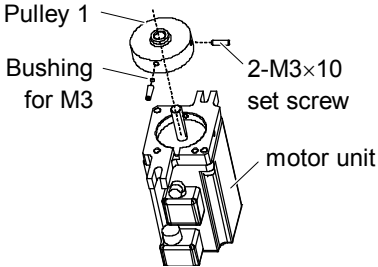
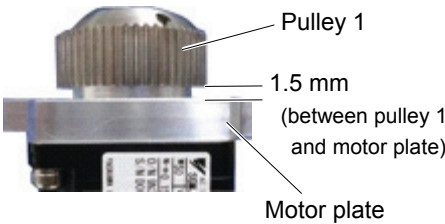

- (4) Insert the Joint #6 motor unit to Arm #4. Be careful not to scratch or catch cables.
- (5) Place the Joint #6 timing belt around the Joint #6 pulley 2.

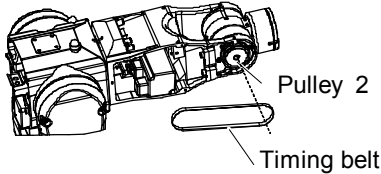

- (6) Pass the pulley 1 of Joint #6 motor unit through the Joint #6 timing belt and loosely secure it to Arm #4.
Make sure that the gear grooves of the timing belt are fit into those of the pulley completely.
When securing loosely the motor unit, make sure the motor unit can be moved by hand, and it will not tilt when pulled. If the unit is secured too loose or too tight, the belt will not have the proper tension.

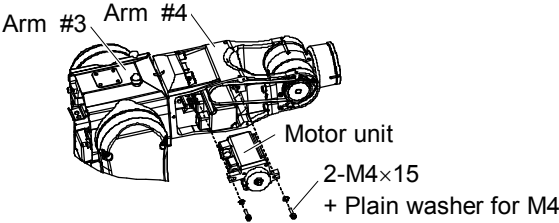

- (7) Apply the proper tension to the Joint #6 motor unit to secure it.

Mount a screw of M4×40 or longer (recommended) to the motor plate.

Pass a suitable cord or string (insulation lock) around the screw. Then, pull the cord using a force gauge or similar tool to apply the specified tension.

Joint #6 timing belt tension = $39.2 \text{ N} \pm 9.8 \text{ N}$ (4 kgf \pm 1 kgf)

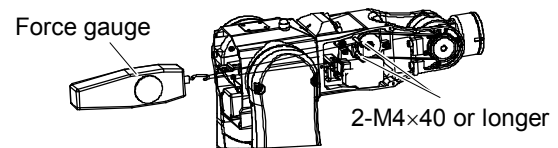

- (8) Mount the Arm #4 side cover.

For details, refer to *Maintenance: 3. Covers.*

- (9) Perform the calibration.

For details, refer to *Maintenance: 16. Calibration.*

10.1.2 Joint #6 motor (with electromagnetic brake)

Removal: Joint #6 motor (with electromagnetic brake)

- (1) Remove the Joint #6 motor unit.

For details, refer to *Maintenance: 10.1.1 Joint #6 motor (without electromagnetic brake)*, Removal step (1) to (4).

- (2) Remove the Joint #6 pulley 1 and driving boss from the Joint #6 motor unit.

There is a brass bushing in one of the set screws fixing the pulley 1 and motor shaft.

Be careful not to lose it.

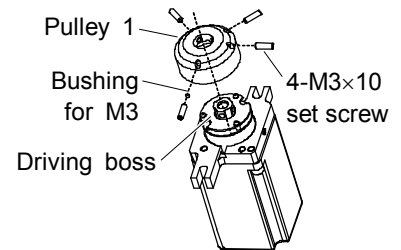

- (4) Remove the motor plate from Joint #6 motor.

- (5) Remove the motor cable from Joint #6 motor.

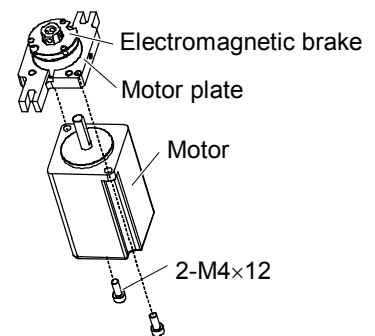

Installation: Joint #6 motor (with electromagnetic brake)

- (1) Mount the motor cable to the Joint #6 motor.

- (2) Mount the motor plate to the Joint #6 motor.

Be careful of the direction of motor plate installation. (See the figure on right side.)

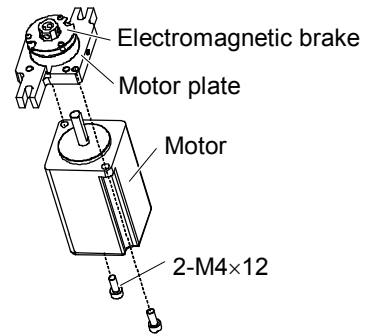

- (3) Mount the driving boss to the pulley 1, and mount the driving boss and pulley 1 to the Joint #6 motor shaft.

Press the pulley 1 to the very end and measure the Distance A (between the pulley 1 and motor plate).

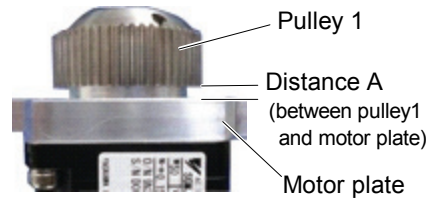

If the Distance A is less than 2.5 mm:
Secure the pulley with the Distance A of 2.5 mm.

If the Distance A is more than 2.5 mm:
Secure the pulley after putting more 0.5 mm space from the position you measured the Distance A.

See the figure for the position of set screws.

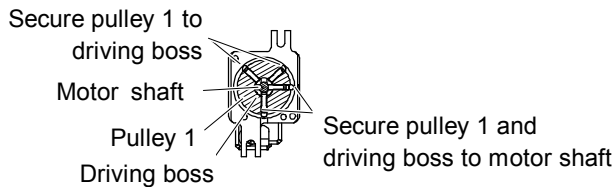
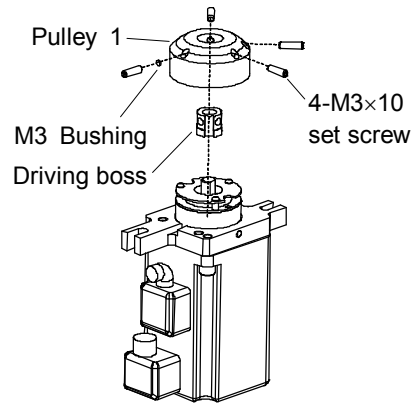

- (4) Assemble and mount the Joint #6 motor unit.

For details, refer to *Maintenance: 10.1.1 Joint #6 motor (without electromagnetic brake)*, Installation step (4) to (10).

10.2 Replacing the Timing Belt

Maintenance Part and Tools

	Name	Quantity	Note
Maintenance Part	Joint #6 timing belt	1	R13B030225
Tools	Hexagonal wrench (width across flats: 2.5 mm)	1	For M3 screw
	Hexagonal wrench (width across flats: 3 mm)	1	For M4 screw
	Force gauge	1	For belt tension

Removal: Joint #6 timing belt

- (1) Turn OFF the controller power supply.
- (2) Remove the Joint #6 side cover.

For details, refer to *Maintenance: 3. Covers*.

- (3) Loosen the set screw of Joint #6 motor unit.

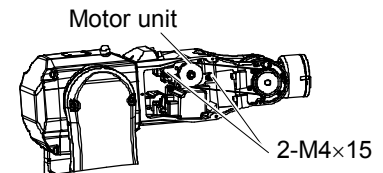

- (4) Remove the Joint #4 timing belt.

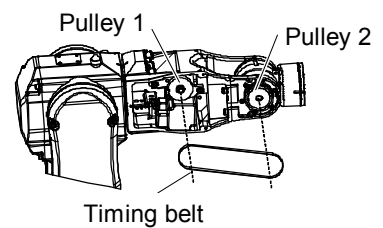

Installation: Joint #6 timing belt

- (1) Place the Joint #6 timing belt around the Joint #6 pulley 1 and pulley 2.
- (2) Secure the Joint #6 motor unit.

For details, refer to *Maintenance 10.1.1 Joint #6 motor (without electromagnetic brake)*, Installation step (6) to (10).

10.3 Replacing the Electromagnetic Brake

Maintenance Part and Tools

	Name	Quantity	Note
Maintenance Part	Joint #6 Electromagnetic brake	1	R13B030506
Tools	Hexagonal wrench (width across flats: 1.5 mm)	1	For M3 set screw
	Hexagonal wrench (width across flats: 2.5 mm)	1	For M3 screw
	Hexagonal wrench (width across flats: 3 mm)	1	For M4 screw
	Force gauge	1	For belt tension

Removal: Joint #6 Electromagnetic brake

- (1) Follow the steps in *Maintenance 10.1.2 Joint #6 motor (with electromagnetic brake)*, Removal step (1) to (2).
- (2) Remove the Joint #6 electromagnetic brake from Joint #6 motor unit.

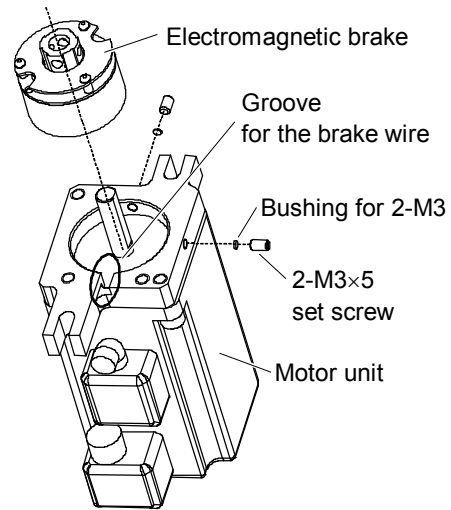

Installation: Joint #6 Electromagnetic brake

- (1) Mount the Joint #6 electromagnetic brake to the Joint #6 motor unit.
 Align the positions of electromagnetic brake wire and groove of motor plate. Then, secure the electromagnetic brake.
 Press the electromagnetic brake into the very end and secure it.

Tightening torque M3:0.7 N·m

- (2) Assemble the motor unit and mount it.
 For details, refer to *Maintenance 10.1.2 Joint #6 motor (with electromagnetic brake)*, Installation step (3) to (4).

11. Replacing the Joint #5 and #6 Unit



- Before performing any replacement procedure, turn OFF the Controller and related equipment, and then pull out the power plug from the power source. Performing any replacement procedure with the power ON is extremely hazardous and may result in electric shock and/or malfunction of the robot system.
- Do not insert or pull out the motor connectors while the power to the robot system is turned ON. Inserting or pulling out the motor connectors with the power ON is extremely hazardous and may result in serious bodily injury as the Manipulator may move abnormally, and also may result in electric shock and/or malfunction of the robot system.
- Be sure to connect the AC power cable to a power receptacle. DO NOT connect it directly to a factory power source. To shut off power to the robot system, pull out the power plug from the power source. Performing any work while connecting the AC power cable to a factory power source is extremely hazardous and may result in electric shock and/or malfunction of the robot system.



- Be careful not to apply excessive shock to the motor shaft during replacement procedures. The shock may shorten the life cycle of the motors and encoder and/or damage them.
- Never disassemble the motor and encoder. A disassembled motor and encoder will cause a positional gap and cannot be used again.

After parts have been replaced (motors, reduction gear units, timing belts, etc.), the Manipulator cannot perform positioning properly because a mismatch exists between the origin stored in each motor encoder and its corresponding origin stored in the Controller. After replacing the parts, it is necessary to match these origins. The process of aligning the two origins is called “Calibration”. Refer to *Maintenance 16. Calibration* and follow the steps that pertain to the software you are using to perform the calibration.

Joint #5 and #6 Unit

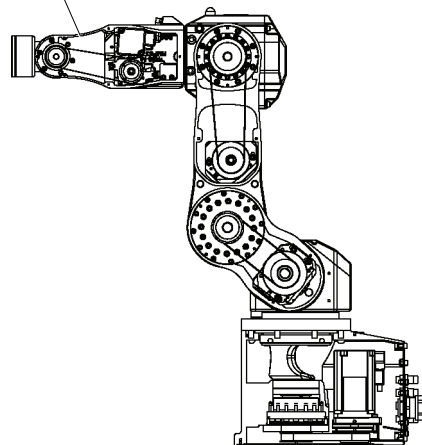

Maintenance Parts and Tools

	Name	Quantity	Note
Maintenance Parts	Joint #5 and #6 Unit	1	R13B080202
	O-ring (Arm #3 - #4)	1	R13B031245
Tools	Hexagonal wrench (Width across flats: 1.5 mm)	1	For M3 set screw
	Hexagonal wrench (Width across flats: 2.5 mm)	1	For M3 screw
	Hexagonal wrench (Width across flats: 3 mm)	1	For M4 screw
	Force gauge	1	For belt tension

Removal: Joint #5 and #6 Unit

- (1) Turn OFF the controller power supply.
- (2) Remove the Arm #3 head cover and Arm #4 side cover.

For the details, refer to *Maintenance: 3. Covers*.

- (3) Remove the Joint #5 timing belt.

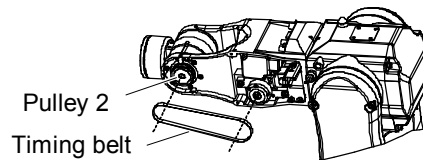

- (4) Remove the Joint #5 motor unit.

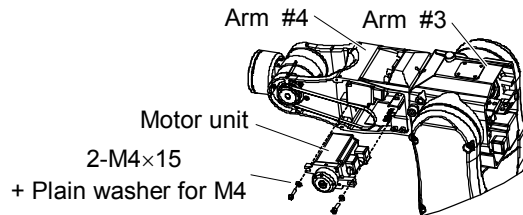
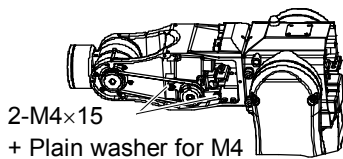

- (5) Remove the Joint #6 timing belt.

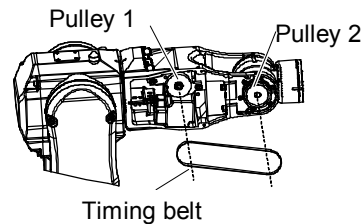

- (6) Remove the Joint #6 motor unit.

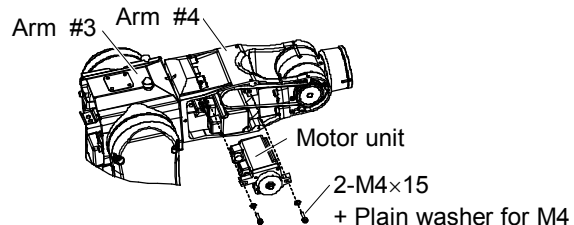
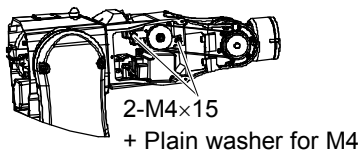

- (7) Remove the connectors below. Open the Arm #3 head cover to get the connectors.
 Connector: X151, X051, X161, X061 (Hold claws to remove.)
 Connector: BT5, BT6
 Connector: BR051, BR061 (Optional when all axes have brakes.)

- (8) Disconnect cables and tubes from the user plate.

For details, refer to *Maintenance: 4.1 Replacing the Cable Unit*.

- (9) Pull out the brake cables and motor cables of Joint #5 and #6.

For details, refer to *Maintenance: 4.1 Replacing the Cable Unit*.

- (10) Remove the Joint #5 and #6 unit.

- (11) Remove the O-ring (Arm #3 - #4).

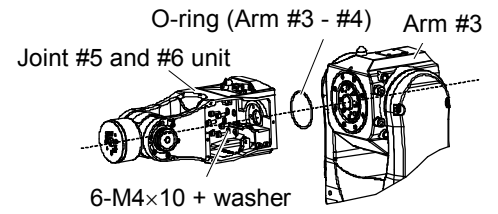

Installation: Joint #5 and #6 Unit

- (1) Mount the O-ring (Arm #3 - #4).

When replacing the Joint #5 and #6 unit, replace the O-ring as well.

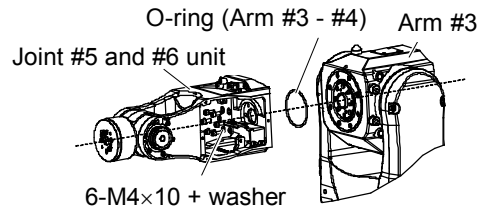

- (2) Mount the Joint #5 and #6 unit to Arm #3.

Put the cables through the spring.

- (3) Place the Joint #6 timing belt around the Joint #6 pulley 2.

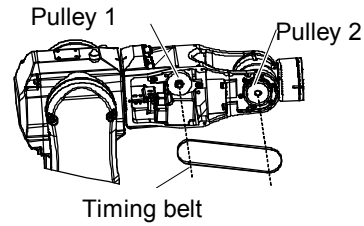

- (4) Pass the pulley 1 of Joint #6 motor unit through the Joint #6 timing belt and loosely secure it to Arm #4.

Make sure that the gear grooves of the timing belt are fit into those of the pulley completely.

When securing loosely the motor unit, make sure the motor unit can be moved by hand, and it will not tilt when pulled. If the unit is secured too loose or too tight, the belt will not have the proper tension.

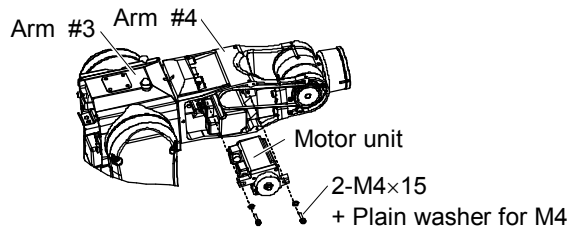
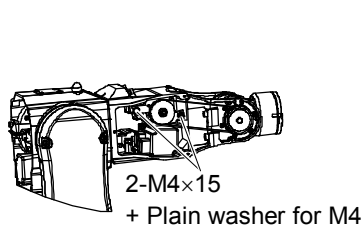

- (5) Mount the Joint #5 timing belt.

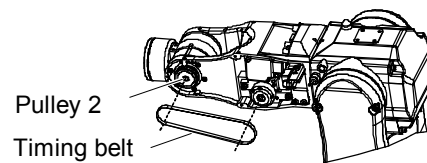

- (6) Pass the pulley 1 of Joint #5 motor unit through the Joint #5 timing belt and loosely secure it to Arm #4.

Make sure that the gear grooves of the timing belt are fit into those of the pulley completely.

When securing loosely the motor unit, make sure the motor unit can be moved by hand, and it will not tilt when pulled. If the unit is secured too loose or too tight, the belt will not have the proper tension.

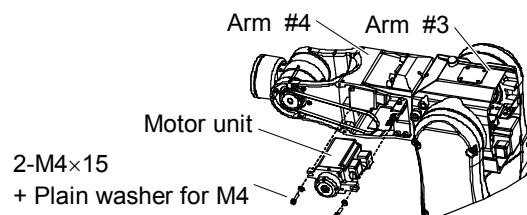
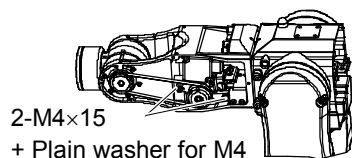

- (7) Pass the brake cables of Joint #5 and #6 through Arm #3.
For details, refer to *Maintenance: 4.1 Replacing the Cable Unit.*
- (8) Connect the connectors.
Connector: X151, X051, BT5, X161, X061, BT6
Connector: BR051, BR061 (Optional when all axes have brakes.)
- (9) Connect the wires and tubes to the user plate.
For details, refer to *Maintenance: 4.1 Replacing the Cable Unit.*

- (10) Apply the proper tension to the Joint #5 motor unit to secure the Joint #6 motor unit.

Mount a screw of M4×40 or longer (recommended) to the motor plate.

Pass a suitable cord or string (insulation lock) around the screw. Then, pull the cord using a force gauge or similar tool to apply the specified tension.

Joint #5 timing belt tension = $39.2 \text{ N} \pm 9.8 \text{ N}$ (4 kgf \pm 1 kgf)

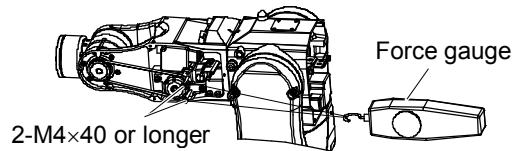

- (11) Apply the proper tension to the Joint #6 motor unit to secure it.

Mount a screw of M4×40 or longer (recommended) to the motor plate.

Pass a suitable cord or string (insulation lock) around the screw. Then, pull the cord using a force gauge or similar tool to apply the specified tension.

Joint #6 timing belt tension = $39.2 \text{ N} \pm 9.8 \text{ N}$ (4 kgf \pm 1 kgf)

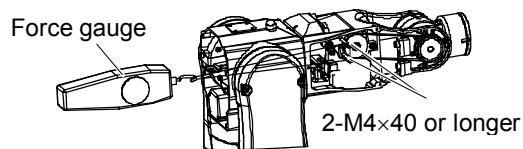

- (12) Mount the Arm #3 head cover and Arm #4 side cover.

For the details, refer to *Maintenance: 3. Covers.*

- (13) Perform the calibration.

For details, refer to *Maintenance: 16. Calibration.*

12. Replacing the Arm #5 O-Ring

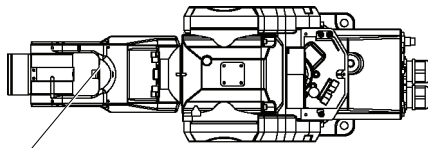

Arm #5 O-ring

Maintenance Part

Name	Quantity	Note
Arm #5 O-ring	1	R13B031245

Removal: Arm #5 O-ring

- (1) Turn OFF the controller power supply.
- (2) Turn Arm #5 to the direction you can easily pull out the plug.

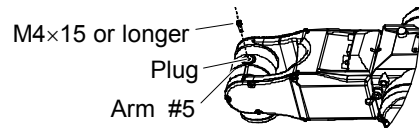

- (3) Insert a screw into the plug.

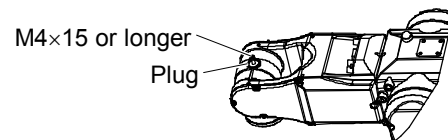

- (4) Hold the screw inserted and remove the plug from Arm #5.

- (5) Remove the O-ring from the plug.



Installation: Arm #5 O-ring

- (1) Mount the O-ring.



- (2) Insert the plug into Arm #5 to the very end.

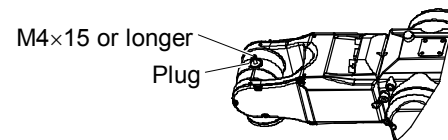
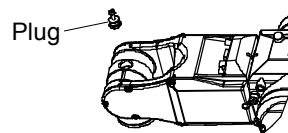

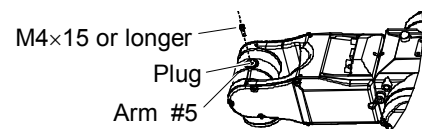

- (3) Remove the screw.

If you move the arm with the screw mounted, it may contact with the manipulator body. Make sure to remove the screw.



13. Replacing the Battery Unit

 WARNING	<ul style="list-style-type: none"> ■ Before performing any replacement procedure, turn OFF the Controller and related equipment, and then pull out the power plug from the power source. Performing any replacement procedure with the power ON is extremely hazardous and may result in electric shock and/or malfunction of the robot system. ■ Do not insert or pull out the motor connectors while the power to the robot system is turned ON. Inserting or pulling out the motor connectors with the power ON is extremely hazardous and may result in serious bodily injury as the Manipulator may move abnormally, and also may result in electric shock and/or malfunction of the robot system. ■ Be sure to connect the AC power cable to a power receptacle. DO NOT connect it directly to a factory power source. To shut off power to the robot system, pull out the power plug from the power source. Performing any work while connecting the AC power cable to a factory power source is extremely hazardous and may result in electric shock and/or malfunction of the robot system.
---	---

 WARNING	<ul style="list-style-type: none"> ■ Use meticulous care when handling the lithium battery. Improper handling of the lithium battery as mentioned below is extremely hazardous, may result in heat generation, leakage, explosion, or inflammation, and may cause serious safety problems. <Improper Handling> <table style="width: 100%; border: none;"> <tr> <td style="width: 50%;">Attempting to charge</td> <td style="width: 50%;">Deforming by pressure</td> </tr> <tr> <td>Disassembling</td> <td>Short-circuit (Polarity; Positive/Negative)</td> </tr> <tr> <td>Connecting batteries improperly</td> <td>Heating (85°C or more)</td> </tr> <tr> <td>Exposing to fire</td> <td>Soldering the terminal of the lithium battery directly</td> </tr> <tr> <td>Forcing discharge</td> <td></td> </tr> </table> ■ When disposing of the battery, consult with the professional disposal services or comply with the local regulation. Spent battery or not, make sure the battery terminal is insulated. If the terminal contacts with the other metals, it may short and result in heat generation, leakage, explosion, or inflammation. 	Attempting to charge	Deforming by pressure	Disassembling	Short-circuit (Polarity; Positive/Negative)	Connecting batteries improperly	Heating (85°C or more)	Exposing to fire	Soldering the terminal of the lithium battery directly	Forcing discharge	
Attempting to charge	Deforming by pressure										
Disassembling	Short-circuit (Polarity; Positive/Negative)										
Connecting batteries improperly	Heating (85°C or more)										
Exposing to fire	Soldering the terminal of the lithium battery directly										
Forcing discharge											

In case of the low lithium battery power, the error that warns the voltage reduction appears at starting the Controller (starting up the software). All position data will be lost and you will need to execute the calibration for all joints.

The life span of the lithium battery is three years. Even if the Manipulator is constantly connected to power, the lithium battery needs to be replaced every three years.

If no warnings of voltage reduction appear, the calibration for all joints is not necessary. However, you need to perform calibration if the position moves from the originals after replaced the battery.

Always use the lithium battery and battery board from our recommended parts.

Be careful of the battery polarity to connect it correctly.

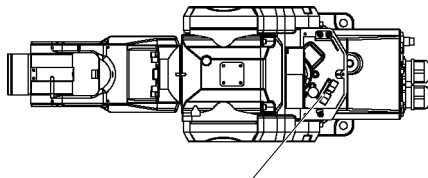

Lithium battery & Battery board

Maintenance parts and Tools

	Name	Quantity	Note
Maintenance Parts	Battery unit (Lithium battery)	1	R13ZA00600300
	Battery board	1	R13B041202
Tools	Nippers	1	
	Hexagonal wrench (width across flats: 3 mm)	1	For M4 screw

13.1 Replacing the Battery Unit (Lithium Bttery)

Removal: Battery unit (Lithium battery)

- (1) Turn OFF the controller power supply.
- (2) Remove the Arm #1 cover.

For details, refer to *Maintenance: 3. Covers*.

- (3) Pull out the battery board from Arm #1.

Carefully pull out the battery board, otherwise the connectors will be disconnected.

Be careful of the cables length.

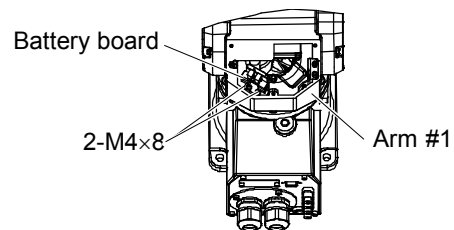

- (4) Connect the connector of new lithium battery to the battery board.

Use the connector available of 2 connectors (X60A, X60B) on the upper side of the battery board.

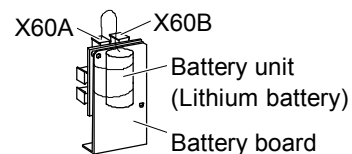

Always connect the new battery unit before disconnecting the old battery unit.

Otherwise, all position data for each arm will be lost and you will need to execute the recovery procedure (ENCRESET).

If you have received the error that warns the voltage reduction, the position data has lost and you do not need to connect the new battery unit before disconnecting the old one.

- (5) Cut off the wire tie that fixes the cable of old battery unit.

Cut off the wire tie that fixes the battery unit to remove it.

Installation: Battery unit (Lithium battery)

- (1) Mount the new battery unit to the battery board.

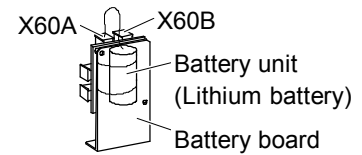

- (2) Mount the battery board to Arm #1.

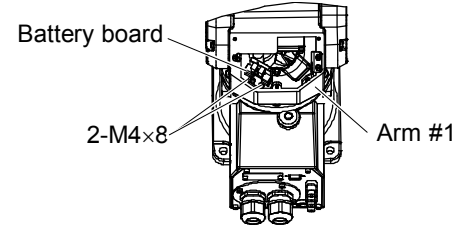

- (3) Mount the Arm #1 cover.

For details, refer to *Maintenance: 3. Covers*.

- (4) Turn ON the controller power supply.
- (5) Check the arms position and orientation.

Move the arms to some points (pose) of the currently registered points.

- (6) If any position and orientation were changed from the originals, perform the calibration for all joints and axes.

For details, refer to *Maintenance: 16. Calibration*.

13.2 Replacing the Battery Board

After parts have been replaced (motors, reduction gear units, timing belts, battery board, etc.), the Manipulator cannot perform positioning properly because a mismatch exists between the origin stored in each motor encoder and its corresponding origin stored in the Controller.

The process of aligning the two origins is called “Calibration”.

After replaced parts, refer to *Maintenance: 16. Calibration* and perform the calibration.

Removal: Battery Board

(1) Turn OFF the controller power supply.

(2) Remove the Arm #1 cover.

For details, refer to *Maintenance: 3. Covers*.

(3) Pull out the battery board from Arm #1.

Carefully pull out the battery board, otherwise the connectors will be disconnected.

Be careful of the cables length.

(4) Disconnect the connectors from the battery board.

Connector: X61, X62, X63, X64

(5) Remove the battery board from the connectors.

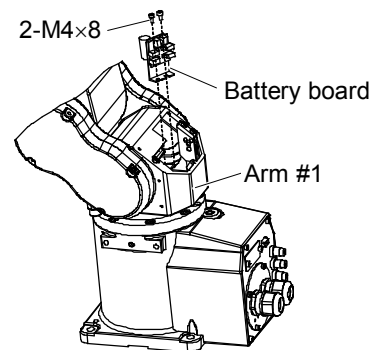
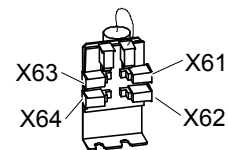
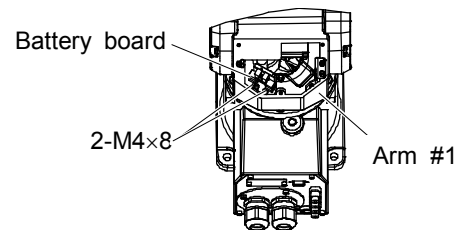

Installation: Battery Board

(1) Connect the connectors.

Connector: X61, X62, X63, X64

(2) Mount the new battery board to Arm #1 and secure it with screws.

(3) Mount the Arm #1 cover.

For details, refer to *Maintenance: 3. Covers*.

(4) Turn ON the controller power supply.

(5) Perform the calibration.

For details, refer to *Maintenance: 16. Calibration*.

14. Replacing the LED Lamp



- Before performing any replacement procedure, turn OFF the Controller and related equipment, and then pull out the power plug from the power source. Performing any replacement procedure with the power ON is extremely hazardous and may result in electric shock and/or malfunction of the robot system.
- Do not insert or pull out the motor connectors while the power to the robot system is turned ON. Inserting or pulling out the motor connectors with the power ON is extremely hazardous and may result in serious bodily injury as the Manipulator may move abnormally, and also may result in electric shock and/or malfunction of the robot system.
- Be sure to connect the AC power cable to a power receptacle. DO NOT connect it directly to a factory power source. To shut off power to the robot system, pull out the power plug from the power source. Performing any work while connecting the AC power cable to a factory power source is extremely hazardous and may result in electric shock and/or malfunction of the robot system.

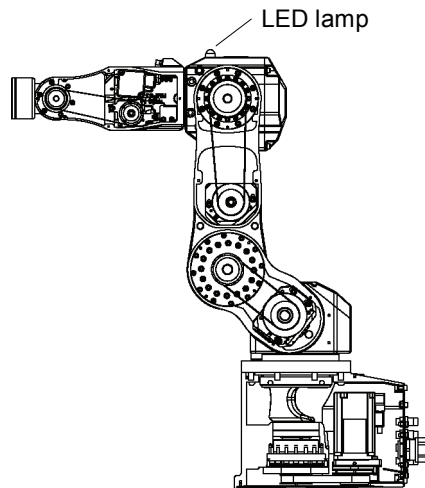

Maintenance Part and Tools

	Name	Quantity	Note
Maintenance Part	LED lamp	1	R13B030005
Tools	Nippers	1	
	Hexagonal wrench (width across flats: 3 mm)	1	For M4 screw

Removal: LED lamp

- (1) Turn OFF the controller power supply.
- (2) Remove the Arm #3 head cover.

For details, refer to *Maintenance: 3. Covers*.

- (3) Disconnect the connector from the LED lamp.

Connector: LEDB

When the Arm #3 head cover is opened, this connector comes out.

- (4) Remove the LED lamp from Arm #3.

Turn the resinous nut inside Arm #3 that fixes the LED lamp counterclockwise.

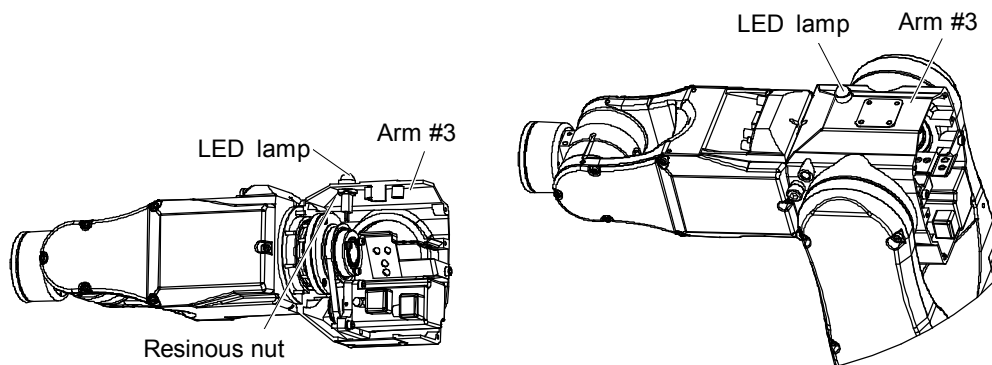

Installation: LED lamp

- (1) Attach the LED lamp.
Detach the resinous nut from the LED lamp and pass the lamp through Arm #3.
Turn the nut clockwise from inside Arm #3 and pinch it in Arm #3 to secure.

- (2) Attach the connector.

Connector: LEDB

- (3) Attach the Arm #3 head cover.

For details, refer to the *Maintenance 3. Covers*.

15. Replacing the M/C Cable

 WARNING	<ul style="list-style-type: none"> ■ Before performing any replacement procedure, turn OFF the Controller and related equipment, and then pull out the power plug from the power source. Performing any replacement procedure with the power ON is extremely hazardous and may result in electric shock and/or malfunction of the robot system. ■ Do not insert or pull out the motor connectors while the power to the robot system is turned ON. Inserting or pulling out the motor connectors with the power ON is extremely hazardous and may result in serious bodily injury as the Manipulator may move abnormally, and also may result in electric shock and/or malfunction of the robot system. ■ Be sure to connect the AC power cable to a power receptacle. DO NOT connect it directly to a factory power source.
---	--

Maintenance Parts and Tool

	Name	Quantity	Note
Maintenance Parts	M/C cable (3 m)	1	R12B020440
	M/C cable (5 m)	1	R12B020441
	M/C cable (10 m)	1	R12B020442
Tool	Hexagonal wrench (width across flats: 3 mm)	1	For M4 screw

Removal: M/C cable

- (1) Turn OFF the controller power supply.
- (2) Remove the connector plate.

For details, refer to *Maintenance: 3. Covers*.
- (3) Disconnect the all connectors from the M/C cable.
- (4) Remove the connector sub plate and M/C cable.

For details, refer to *Maintenance: 3. Covers*.

Installation: M/C cable

- (1) Attach the M/C cable and the connector sub plate to the connector plate.
- (2) Attach all connectors disconnected in Removal step (3).
- (3) Attach the connector plate to the base.

For details, refer to the *Maintenance 3. Covers*.

- (4) Turn ON the controller power supply.
- (5) Check the arms motion if the position and orientation have not changed.
- (6) Move the arms to some points (poses) of currently registered points (poses).
- (7) If the position and orientation have changed from the originals, perform the calibration for all joints and axes.

For details, refer to *Maintenance 16. Calibration*.

16. Calibration

16.1 Overview

After parts have been replaced (motors, reduction gear units, timing belts, etc.), the Manipulator cannot perform positioning properly because a mismatch exists between the origin stored in each motor encoder and its corresponding origin stored in the Controller. After replacing the parts, it is necessary to match (correct) these origins.

The process of aligning the two origins is called “Calibration”. Note that calibration is not the same as teaching*.

* “Teaching” means to teach the Controller coordinate points (including poses) anywhere in the operating area of the Manipulator.

 WARNING	<ul style="list-style-type: none"> ■ To ensure safety, a safeguard must be installed for the robot system. For details on the safeguard, refer to the <i>Installation and Design Precautions</i> in the <i>Safety</i> chapter of the EPSON RC+ User’s Guide. ■ Before operating the robot system, make sure that no one is inside the safeguarded area. The robot system can be operated in the mode for teaching even when someone is inside the safeguarded area. The motion of the Manipulator is always in restricted (low speeds and low power) status to secure the safety of an operator. However, operating the robot system while someone is inside the safeguarded area is extremely hazardous and may result in serious safety problems in case that the Manipulator moves unexpectedly.
---	---

For EPSON RC+, a coordinate point including the arm pose is defined as “point”. The data is called “point data”.

There are two methods to move the Manipulator during calibration.

- Releasing the electromagnetic brake and moving the arms manually
For details, refer to the *Setup & Operation 1.5 How to Move Arms the Electromagnetic Brake is Applied to*.
- Moving the Manipulator using Jog & Teach.
For details, refer to *EPSON RC+ User’s Guide 5.11.1 Robot Manager Command Tools: Robot Manager: Jog and Teach Page*

It is recommended that you move the Manipulator using Jog & Teach since moving the Manipulator while releasing the electromagnetic brake involves risk.

 CAUTION	<ul style="list-style-type: none"> ■ Normally, release the brake of a single joint at a time. Take extra care to release the brakes of two or more joints simultaneously from necessity. Releasing the brakes of two or more joints simultaneously may cause hands and fingers to be caught, serious bodily injury and/or severe equipment damage to the Manipulator as the arms of the Manipulator may move in unexpected directions. ■ Be careful of the arm falling when releasing the brake. While the brake release switch is pressed, the Manipulator’s arm falls by its own weight. The arm falling may cause hands and fingers to be caught and/or may cause equipment damage to or malfunction of the Manipulator.
---	---

NOTE



- For details about the basic pose, refer to the *Setup & Operation 3.7 Checking the Basic orientation.*
- Whenever possible, calibrate the origin one joint at a time. (Replace parts one joint at a time whenever possible.) If you calibrate the origins for multiple joints simultaneously, it will be more difficult to verify their origins and obtain the origin positions. However, joint #5 cannot be calibrated alone according to the structure of the Manipulator. Make sure you calibrate joint #6 at the same time.

Calibration Flowchart

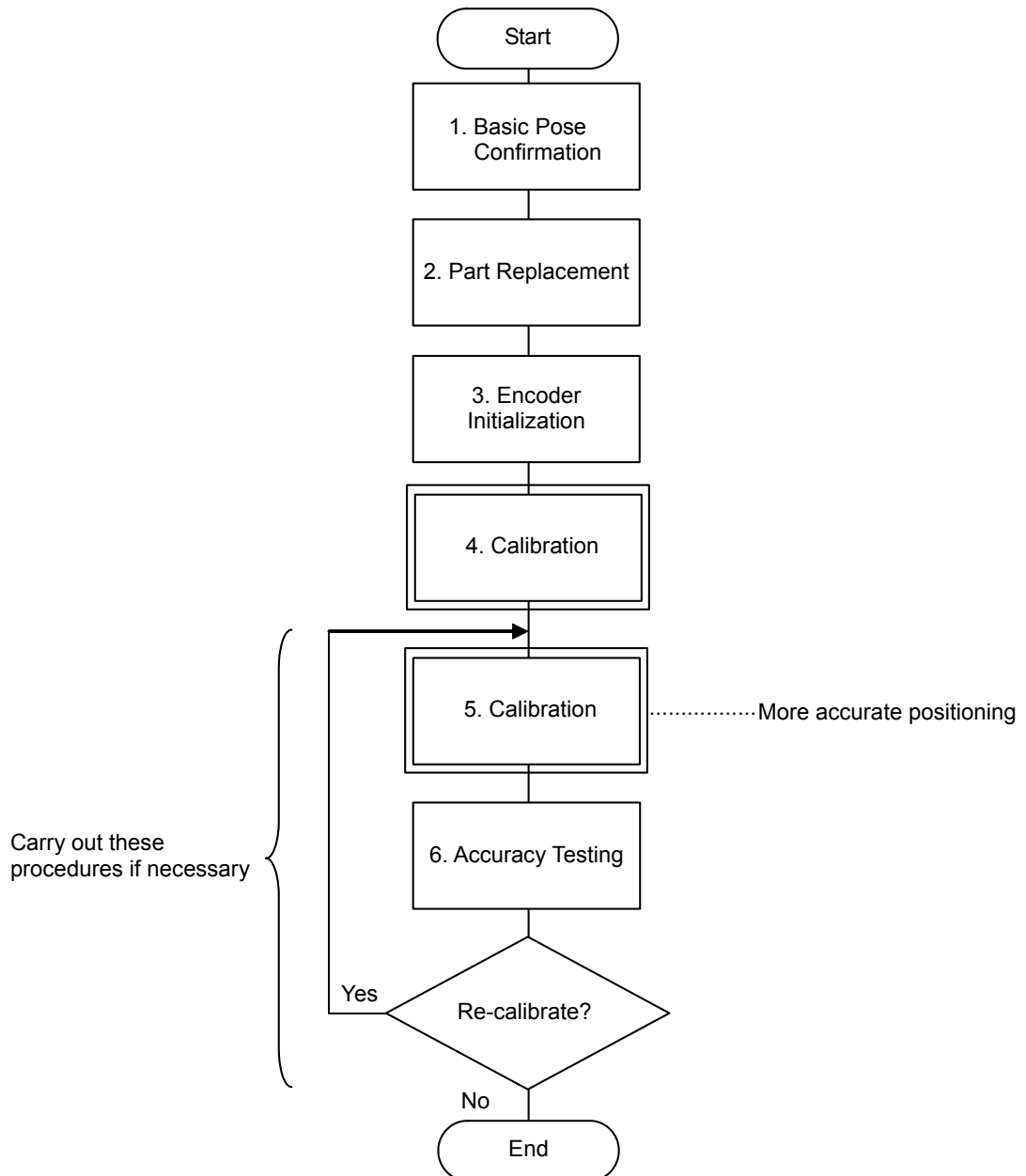

16.2 Calibration Procedure

Command Input

Calibration procedures include command execution.

Select the EPSON RC+ menu-[Tools]-[Command Window].

The information above is omitted in the calibration procedure.

Jog Motion

The process to set the jog motion is included in the calibration procedures.

Select EPSON RC+ menu-[Tools]-[Robot Manager] and select the [Jog & Teach] page.

The panel, window, and page above are indicated as [Jog & Teach] in this section.

Follow steps 1 to 6 described below in order to calibrate the origin.

1. Basic Pose Confirmation

Verify the recorded pulse values of the basic pose obtained in the *Setup & Operation 3.7 Checking the Basic orientation*.

2. Part Replacement

Replace parts as dictated by this manual. Be careful not to injure yourself or damage parts during part replacement.

3. Encoder Initialization

Turn ON the Controller when all joints are in the motion range.

“Encoder alarm has occurred. Check robot battery. EPSON RC+ must be restarted.” is displayed

Initialize the encoder at the current position and reset the error.

Initialize the encoder using one of the following procedures.

Execute the following command at the [Monitor Window].

>Encreset [The joint number (1 to 6) corresponding to the encoder will be reset]

Select Tools | Controller, then click the [Restart Controller] button.

After resetting the error, the motor encoder of the parts replaced joint is initialized. Set the jog mode to “Joint” from the [Jog & Teach] and operate the Manipulator in jog motion to match the home position of the joint accurately.

When the joint does not move to the home position, operate the Manipulator to match the tram mark placed in *Setup & Operation 3.7 Checking the Basic orientation* as accurate as possible.

Initialize the joint encoder when the joint matches the home position or the tram mark. For the encoder initialization, refer to the procedure indicated above.



When the origin of Joint #5 is calibrated, Joint #6 will be out of position.

(Due to the structure of the Manipulator, any offset in the position of Joint #5 affects Joint #6.) Calibrate the origin of Joint #6 at the same time when calibrating Joint #6.

4. Calibration

Position of grooves for calibration

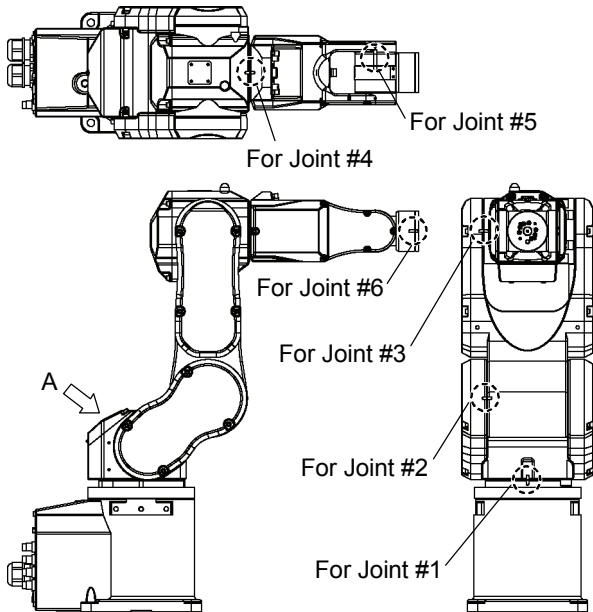

Position of calibration key

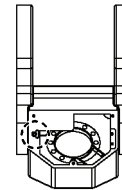

Detail of A
(Arm #1 center cover is removed)

The key is secured to inside of Arm #1 center cover using M4 screw.

Be sure to put the key back to the original position after use.

4-1 Prepare the calibration key.

One calibration key is secured inside the Arm #1 center cover using M4 screw. Be careful not to lose the screw.

4-2 Move the arm you want to calibrate to the position of calibration groove.

Use the Tool | Robot Manager | Jog & Teach panel.

If an error occurs such as after replaced the motor and you cannot use the [Jog & Teach] panel or “Brake OFF, *” does not work (* is an axis number to calibrate.), go through the steps (4) and (5) now.

Then, you can use the [Jog & Teach] panel and Brake OFF, *. Move the arm you want to calibrate to the position of calibration groove and go on to the step 3.

4-3 Set the calibration key to the calibration groove (the grooves for Joints #1 to #6).

At this point, if the key cannot be set completely, the arm(s) is not in the origin. Move the arm until the key can completely be set.

The key will be broken if you move any arm with the key in groove. Do not move arm(s) once its position is fixed.

4-4 Reset the encoder.

Execute one of the commands below for the joint you want to reset the encoder from the Tool | Command window.

```

Joint #1 >Encreset 1
Joint #2 >Encreset 2
Joint #3 >Encreset 3
Joint #4 >Encreset 4
Joint #5 >Encreset 5, 6
Joint #6 >Encreset 6

```

4-5 Reboot the controller.

Click the Tool | Controller | Reset Controller.

4-6 Input the data in the Command window as below and execute it.

```

>calpls 0,0,0,0,0,0
* Manipulator does not move.

```

4-7 Perform the calibration.

Execute one of the commands below for the joint you want to calibrate from the Tool | Command window.

```

Joint #1 >calib 1
Joint #2 >calib 2
Joint #3 >calib 3
Joint #4 >calib 4
Joint #5 >calib 5, 6
Joint #6 >calib 6

```

Move the arm to several points to check if the arm moves to the original positions properly. Teach points if fine adjustment is required.

4-8 All joints are calibrated.

Put the calibration key back to the original position in Arm #1 and secure with the screw.

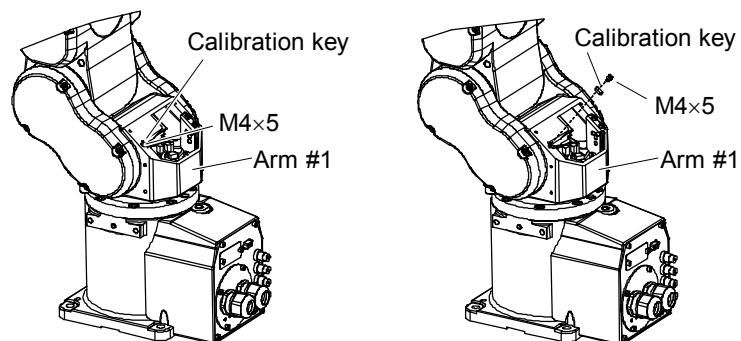

4-9 Mount the Arm #1 cover.

For details, refer to *Maintenance: 3. Covers*.

5. Calibration (More accurate positioning)

Move the Manipulator to the selected point data by jogging executed from the [Jog & Teach].

Move the joint* being calibrated to the specified point by motion command.

*You must also move Joints #1 - #4 to the position when calibrating Joint #5.

For example, when the specified point data is "P1", "Motor On" is executed from [Control Panel] and "Go P1" is executed from [Jog & Teach].

Accurately conform the calibrating joint* to the specified point data by jog command.

*You must also move Joint #5 and #6 to the position when calibrating Joint #5.

Select the Joint jog mode from the [Jog & Teach] to execute the jog motion.

Perform the calibration. Input one of the following commands according to the joint being calibrated.

```
Joint #1 :>Calib 1
Joint #2 :>Calib 2
Joint #3 :>Calib 3
Joint #4 :>Calib 4
Joint #5 :>Calib 5,6
Joint #6 :>Calib 6
```

6. Accuracy Testing

Move the Manipulator into a different pose (point) to verify the reproducibility of the position. If accuracy is inadequate, it may be necessary to re-calibrate the origin using a different pose (point). You must set the pose (point) again if reproducibility cannot be assured through calibration.

17. Maintenance Parts List

Be sure to specify the proper codes when ordering maintenance parts.

Part Name		Code	Note	Reference
Motor	Joint #1, #2	R13B000616	400 W	95, 107
	Joint #3	R13B000618	150 W	117
	Joint #4	R13B000619	50 W	127
	Joint #5, #6	R13B000620	50 W	141, 147
Reduction Gear Unit *	Joint #1	R13B010011		101
	Joint #2	R13B010021		111
	Joint #3	R13B010022		121
	Joint #4	R13B010023		133
Electromagnetic Brake	Joint #2 (Joint #1 **)	R13B030504		105, 115, 125, 139, 145, 153
	Joint #3	R13B030505		
	Joint #5 (Joint #4, #6 **)	R13B030506		
Timing Belt	Joint #1	R13B030220	Width 10 mm	104
	Joint #2	R13B030221	Width 10 mm	114
	Joint #3	R13B030222	Width 7 mm	124
	Joint #4	R13B030223	Width 6 mm	138
	Joint #5	R13B030224	Width 6 mm	144
	Joint #6	R13B030225	Width 6 mm	152
Battery Board (Lithium battery is supplied)		R13B041202	Lithium battery: ER17330V (TOSHIBA)	161
Battery Unit (Spare lithium battery)		R13ZA00600300		160
LED Lamp		R13B030005		162
O ring	Joint #1	R13B031223		102
	Joint #2	R13B031242		112
	Joint #3	R13B031243		122
	Joint #4	R13B031244		136
	Arm #3, #4	R13B031245		155
	Arm #5	R13B031247		158
Seal	Joint #4	R13A031200100		135
Joint #5, #6 Unit		R13B080202		154
Grease	Joints #1 ~ #4	R13ZA00330100	SK-1A (500 g)	66
	Bevel gear	R13ZA00330400	SK-2 (500 g)	66
	Cable	R13B030304	Tube of GPL-224 (227 g)	78
M/C Cable		R12B020440	3 m	164
		R12B020441	5 m	
		R12B020442	10 m	
Cable Unit		R13B020036	Internal cable	78
Noise Reduction Diode	Joint #2, #3 (Joint #1 **)	R13B020301		99, 107, 117
Heat Dissipating Sheet	Joint #1, #2	R13B031905		97, 109

** Option: Brakes are equipped to all joints.

Option

Part Name	Code	Note	Reference
Brake Release Unit (with cable and short connector)	R12B120805	For Europe	45
	R12B120806	For U.S. & Japan	
Brake Release Unit (Main unit only)	R12B120803	For Europe	
	R12B120804	For U.S. & Japan	
Camera Plate Unit	R12B031922		50
PS Compatible Plate	R12B031923		53
Base Side Angled Fitting	R12B031924		54
Base Side Fitting	R12B031925		57

* Reduction Gear Unit

A reduction gear unit consists of the following three parts. When replacing the reduction gear unit, be sure to always replace the waveform generator, flexspline, and circular spline all together as one set.

Waveform generator

This waveform generator consists of an ellipsoidal cam with ball bearings on its outer circumference.

The inner ring of bearings is secured to the cam, while the outer ring is capable of flexible deformation through the ball bearings.

Flexspline

A thin, elastic, cup-shaped metal body with gear teeth around the outer circumference of the opening.

Circular spline

A rigid, ring-shaped body with gear teeth on the inner circumference.

The circular spline has two more teeth than the flexspline does.

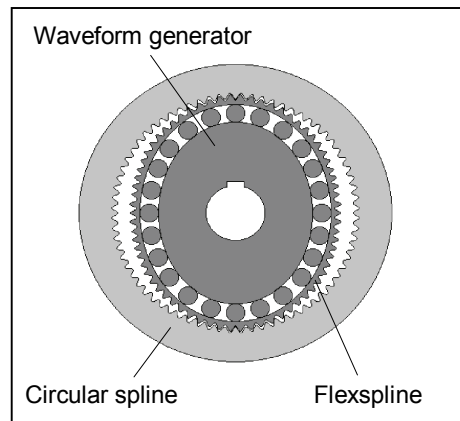

The splines are greased. Be sure to keep the grease from being attaching to the clothes.