

Good Thinking, Good Future

Ultra High-Accuracy Laser Displacement Sensor

FASTUS

CDX series



World's No. 1 Linearity

OPTEX FA CO., LTD.

A fusion of ultra high-accuracy and ease-of-use

We have accumulated decades of know-how since our first laser displacement sensor was introduced to market, all which have been utilized to achieve the World's No. 1 measurement accuracy.

We arrived at a simple configuration by examining various user needs and are able to provide operability by way of a built-in Web server, a new concept for displacement sensors.

Featuring a fusion of ultra high-accuracy and ease-of-use, these laser displacement sensors feature an extremely high level of perfection.

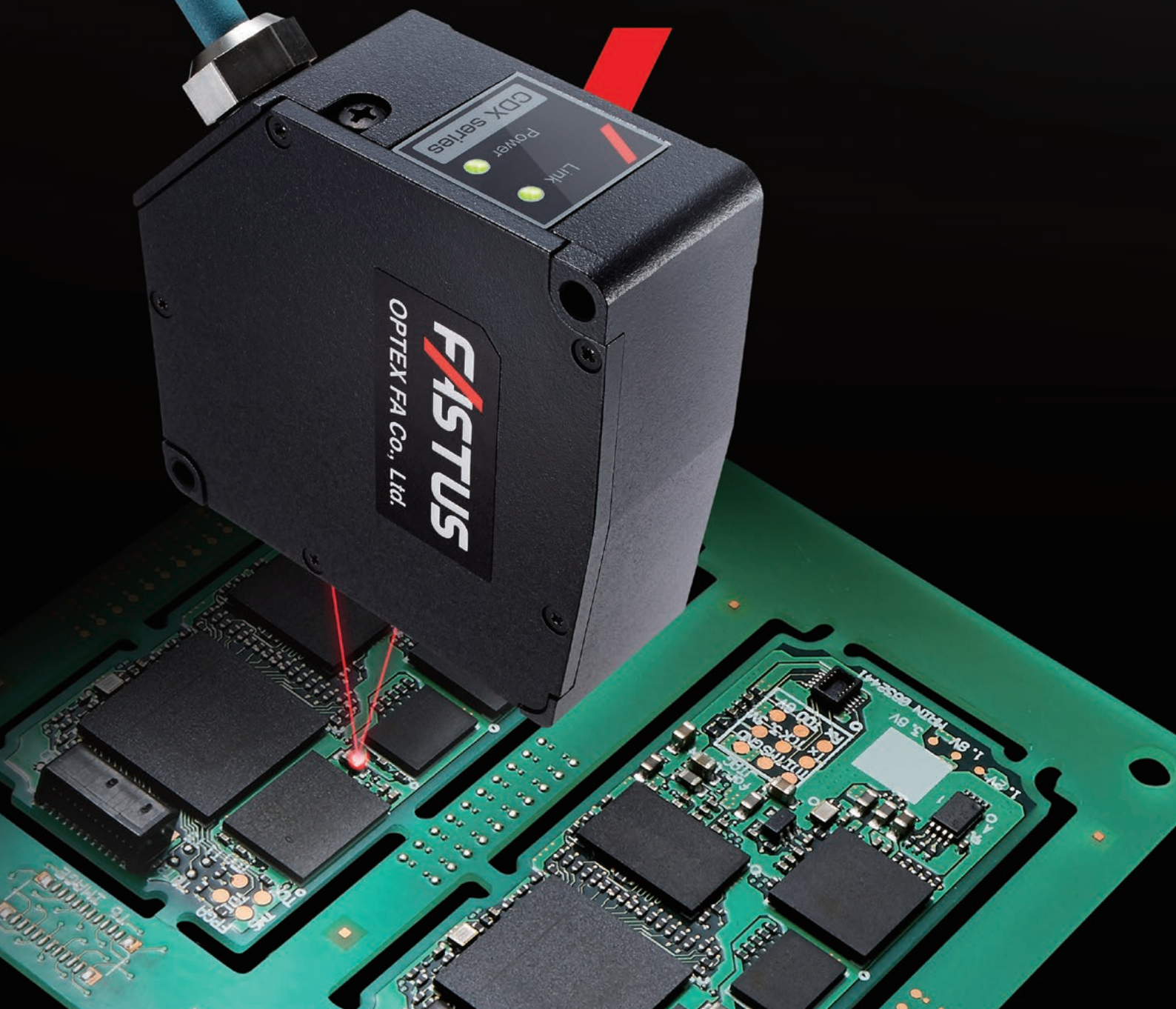

Advanced Opto-technology & High-rigidity design

Featuring unprecedented linearity thanks to an advanced optical system and highly-rigid body

In order to enable ultra high-accuracy measurements to be performed, a specially-designed optical system and rigid body with an independent base unit structure have been adopted. Featuring advanced levels of both accuracy and high speed, causes of errors have been successfully shut out.

Highly-rigid body structure
High rigidity is ensured by providing an independent base unit only to the optical system



Light receiving element
ATOMOS

Emitting part
Cylindrical lens

Employed for wide spot type.

Receiving part
Neo LD lens

A CDX specially-designed lens featuring a 4-group-4-element structure. High linearity has been realized thanks to a new optical design with low-aberration.

*Example with the diffuse-reflective type

New algorithm

Linearity has been successfully restrained through use of a newly-developed original measurement algorithm. By performing a thorough review of our algorithm, ultra high-accuracy measurements have been achieved.

Ultra High-Accuracy Laser Displacement Sensor

CDX Series

World's No. 1 Linearity

$\pm 0.015\% F.S.$

* For triangulation method diffuse-reflective type displacement sensors. Optex FA examination performed November 2016.

Linearity comparison

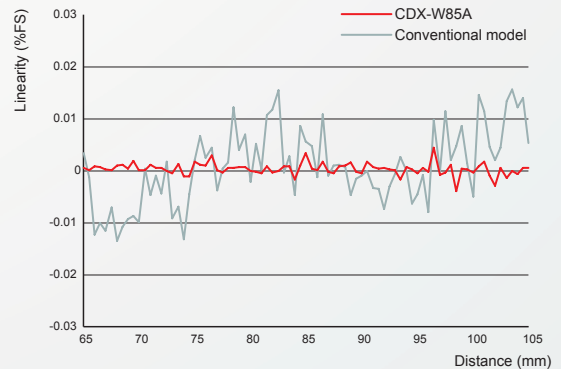

Featuring the World's No. 1 linearity that easily satisfies the $[\pm 0.015\% F.S.]$ catalog specification, CDX series models realize measurements with significantly higher levels of accuracy than the conventional model.

* Workpiece angle: $\pm 0^\circ$, diffuse mode.
Refer to P. 10 for measurement conditions.

Neo LD lens



The light receiving lens has been customized to enable light reflected from the measurement target to be focused with high accuracy on the light receiving element. Error-causing spot distortions that arise due to lens aberration have been decreased significantly.

Neo LD: Neo Low Dispersion

Newly Developed Image Sensor for Highly Accurate, High-speed, and Stable Measurements

NEW Newly developed image sensor: ATMOS

In order to achieve the World's No. 1 Linearity, ATMOS image sensors were newly developed with a light receiving element featuring a CDX specialized design. By applying the latest technology, accuracy has been increased by 2.7 times that of the conventional model.

ATMOS: Auto Tuning cMOS

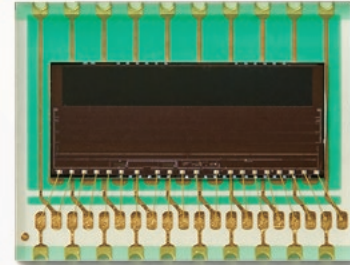

Industry first Feedback-free high-speed shutter

With conventional image sensors, feedback control to the shutter could not keep up with sudden changes in receiving light quantities caused by changes in workpiece colors, momentary inabilities to perform measurements would be caused, resulting in response delays. With newly developed ATMOS image sensors, measurements can be performed without the need for feedback control thanks to an industry-first algorithm. Because momentary inabilities to perform measurements and response delays have been eliminated, real-time measurements are now possible.

When receiving light quantity changes suddenly

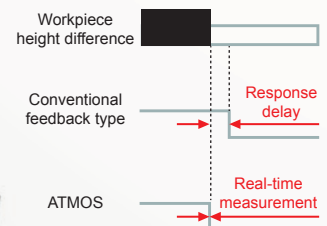
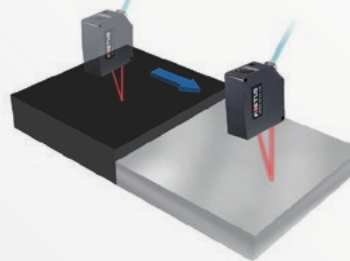

Stable measurements even with Class 1 lasers

With ATMOS image sensors, stable measurements are possible even with a Class 1 laser thanks to their high level of sensitivity. Even when measuring black workpieces such as tires, highly accurate measurements can be performed without using a high output laser. Stable measurement of black workpieces is possible while ensuring the safety of worker's eyes.

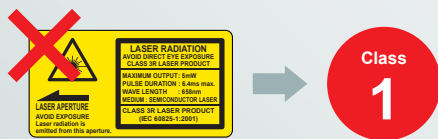
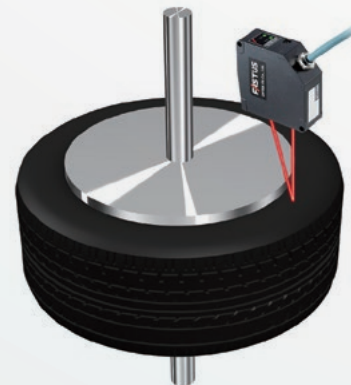

High-speed measurement: Max. sampling period of 12.5 μs (Measuring frequency: 80 kHz)

With highly sensitive ATMOS image sensors, ultra high-speed shutter speeds are possible as the required exposure time is minimized. Because sampling periods have been reduced to 12.5 μs, 1/8th of the conventional model, these sensors can be utilized for application that require ultra high-speed measurements.

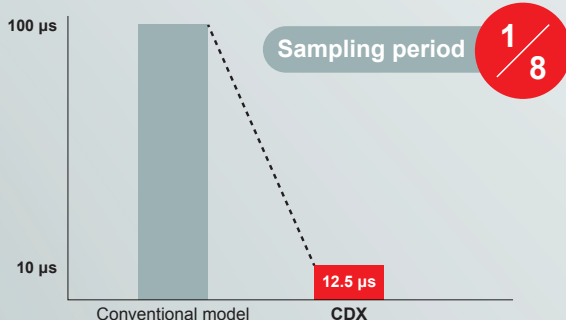

Large glass height measurement

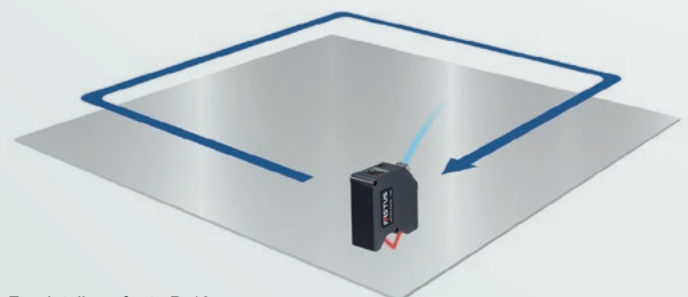

*With a sampling period of 12.5 μs, the measurement range will be limited. For details, refer to P. 10.

Applications

Shape measurement of cam shafts

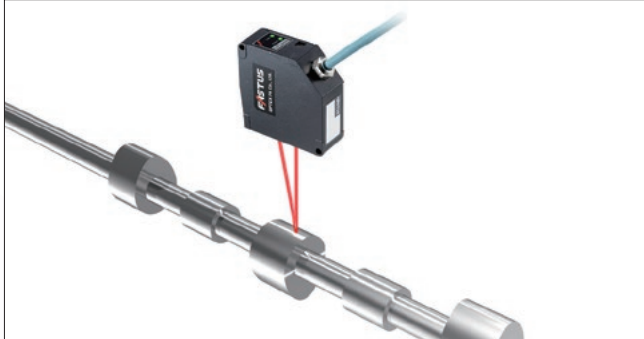

Shape measurement of tires

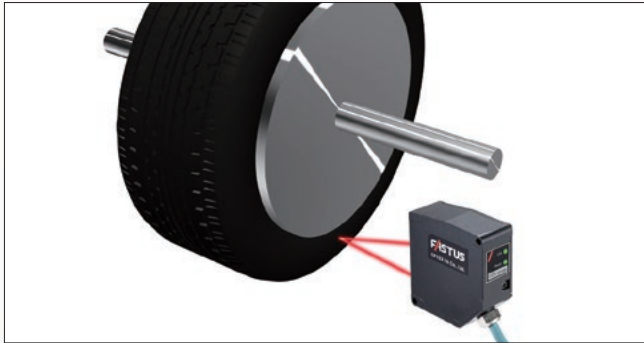

Flatness measurement of transmission parts



Deflection measurement of large diameter drills



Height inspection of smartphone frames (specular reflection type)



Warping measurement of glass substrates (specular reflection type)

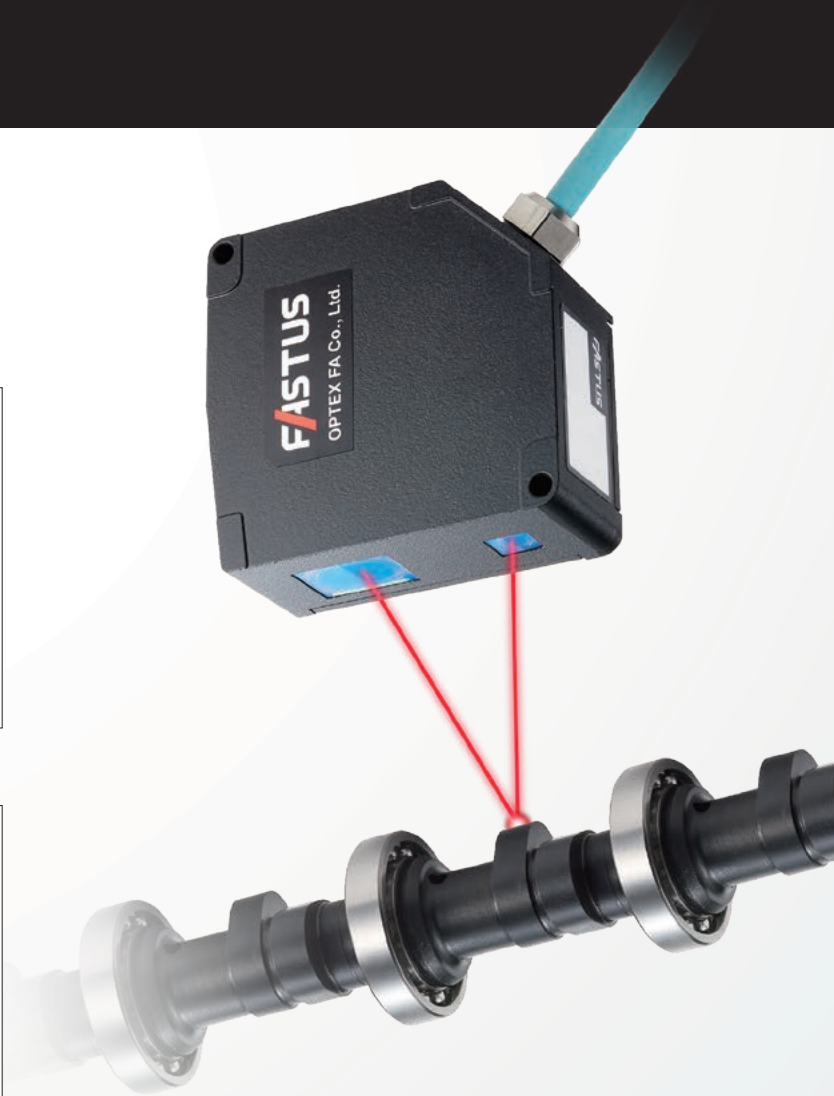
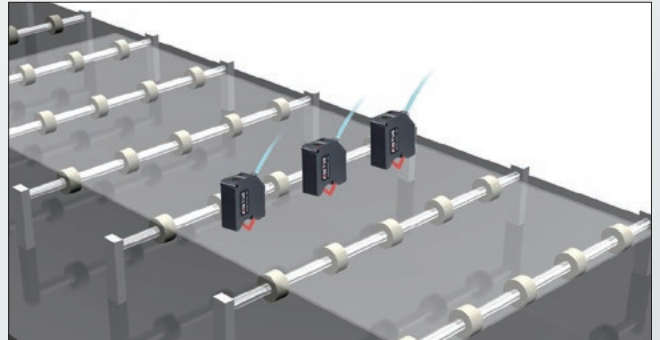

Direct Network Connections are Possible without Use of a Controller

NEW Direct Ethernet connection

Because an Ethernet serial interface is built-in to the sensor head, connection to a network is possible without use of a controller. Not only can the cost of a controller be eliminated, but any worries about securing space for controller installation can also be forgotten.

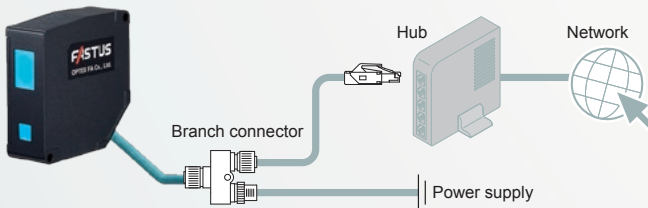

■ Operation is possible by connecting directly to a PC LAN port

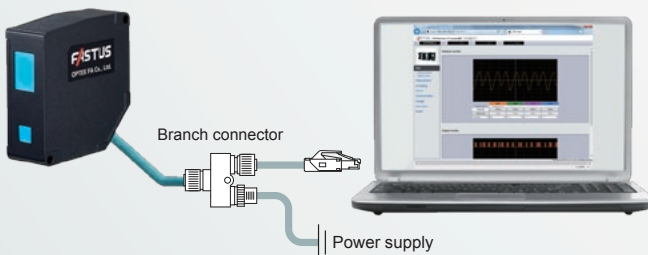

■ Of course, connection to a PLC Ethernet port is also possible

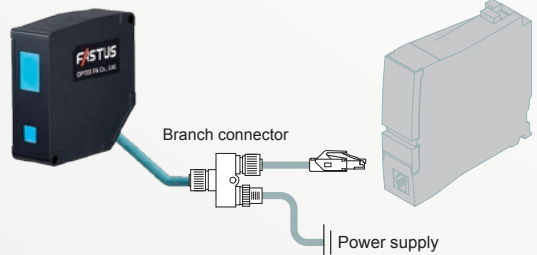

When Analog/Control Output is Necessary

Displacement sensor amplifier unit CDA-M

The CDA-M amplifier unit is equipped with an organic EL display on which both Japanese characters and English lettering can be viewed with clarity. Control can be performed using either analog or control outputs, while thickness and height difference measurements can be performed using two sensor heads.



Model		CDA-M
Sensor head (CDX series)	No. of connectable units	Max. 2 units
	Connection type	Amplifier side: M8, 4-pin connector
Rating	Supply voltage	12 to 24 VDC +/-10%, including 10% ripple (p-p)
	Current consumption	100 mA or less (at 12 V)
Display	Dot matrix display	Organic EL panel 128 × 96 pixels
	Indicators	Power display: Red/Green, Output 1 to 3 display: Orange
Analog current output		4 to 20 mA/F.S. Load impedance 300 Ω or less
Control output		NPN/PNP open collector (selectable by setting) 3 outputs max. 100 mA / 30 VDC, Residual voltage: 1.8 V or less
External input		2 inputs
Connection type		Cable type: Cable length: 2 m (ø5.8 mm)
Environmental resistance	Ambient temperature/humidity	-20 to +50°C / 35 to 85% RH (no freezing or condensation)
	Storage temperature/humidity	-20 to +60°C / 35 to 85% RH (no freezing or condensation)
	Vibration resistance	10 to 55 Hz; double amplitude 1.5 mm; 2 hours in each of the X, Y, and Z directions
	Shock resistance	Approx. 50 G (500 m/s ²), 3 times in each of the X, Y, and Z directions
	Protection circuit	Reverse connection protection
Degree of protection		IEC standard, IP50
Material		Polycarbonate
Weight		170 g

○ If using an amplifier unit, some settings for the CDX series cannot be confirmed or changed. For details, see the CDX series user's manual.
 ○ On the CDX series, CH1 is the only output that can be set and used with an amplifier unit.
 ○ The CDX series does not support CC-Link communication.
 ○ The resolution of the analog outputs (shown below) will be lower than that when using Ethernet communication.
 CDX-85A-W85A: 10 μm, CDX-150A-W150A: 10 μm

/ Equipped with a Web Server

NEW Setup software is unnecessary

The CDX series features a new Web server. Using a web browser on the computer connected to the same network, browsing and controlling measured values and setup contents are possible. Use is possible without need for a dedicated computer software.

Supported browsers Internet Explorer Ver.11 and above, Google Chrome 49 and above

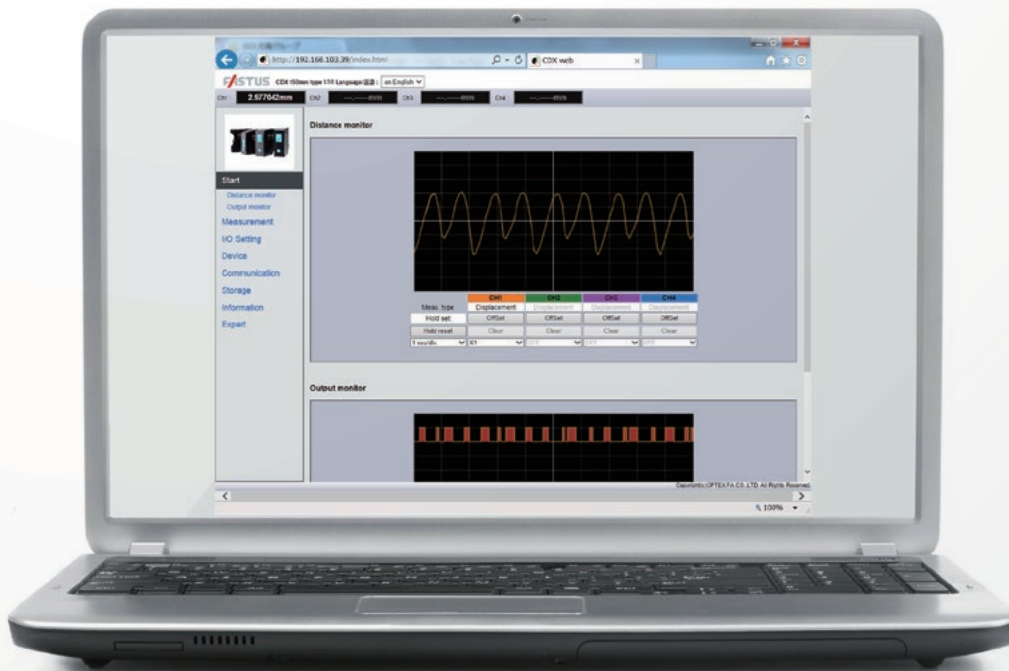

Main functions

■ Distance monitor

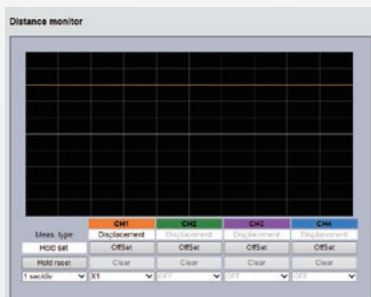

Viewing on both a measured value display (numerical) and graph display is possible. Offsetting can also be performed while viewing this screen. It features an internal 4ch processing system that enables displacement, thickness, speed, and acceleration to be monitored simultaneously.

■ Storage

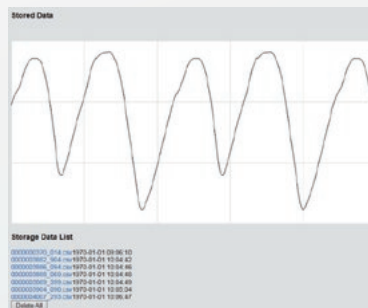

Measured values for up to 100,000 points can be stored. By operating using a browser, data can be viewed and CSV files can be downloaded.

■ Light distribution

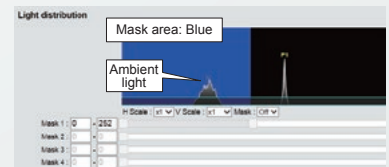

By monitoring receiving light waveforms, receiving light quantities and mounting angle can be confirmed. Thanks to a newly developed mask function, even if there are unnecessary mask objects or ambient light in the measurement range, those can be masked to enable measurements to be performed free of influence.





Other functions

■ Measurement setting ■ I/O setting ■ Device setting ■ Communication setting ■ Product information etc.

- Internet Explorer and the Internet Explorer logo are trademarks or registered trademarks of Microsoft Corporation in the United States and other countries.
- Google Chrome and the Google Chrome logo are trademarks or registered trademarks of Google Inc. in the United States and other countries.





Lineup

■ Sensor heads



Type		Measurement range		Spot size	Resolution	Linearity		Model						
						Diffuse mode	Specular mode							
Middle range	Spot	85 +/-20 mm	81.5 +/-10 mm	ø70 µm	0.3 µm	Meas. range 65 to 85 mm: +/-0.018% of F.S.(+/-7.2 µm) Meas. range 85 to 105 mm: +/-0.03% of F.S.(+/-12.0 µm)	+/-0.03% of F.S. (+/-6.0 µm)	CDX-85A						
	Wide	 Diffuse installation	 Specular installation	70 × 2000 µm		+/-0.015% of F.S. (+/-6.0 µm)		CDX-W85A						
Long range	Spot		150 +/-40 mm	ø120 µm		Meas. range 110 to 150 mm: +/-0.03% of F.S.(+/-24 µm) Meas. range 150 to 190 mm: +/-0.04% of F.S.(+/-32 µm)	—	CDX-150A						
	Wide			120 × 4000 µm		+/-0.015% of F.S. (+/-12 µm)		CDX-W150A						
Specular reflection	Spot	Coming soon						CDX-L15A						
	Wide							CDX-LW15A						
Short range	Spot													CDX-30A
	Wide													CDX-W30A

Options/Accessories

■ Connectors/Connector Cables

Type	Specifications	Cable length	Model
 Sensor head extension cable	Dedicated cable for extension between the sensor head and branch connector. Extension up to 20 m is possible. Robot cable specifications. • Sensor side: M12, 8-pin socket • Branch connector side: M12, 8-pin plug	2 m	DSC-1208-G02MA
		5 m	DSC-1208-G05MA
		10 m	DSC-1208-G10MA
 Ethernet cable	Dedicated cable for connecting from the branch connectors to the Ethernet port. Robot cable specifications. • Branch connector side: M12, 4-pin socket • Host side: RJ45 plug	2 m	SSL-2J04-G02ME-R
		5 m	SSL-2J04-G05ME-R
		10 m	SSL-2J04-G10ME-R
 Power supply/external input cable	Power supply/external input cable for connecting to branch connector. • Branch connector side: M12, 4-pin socket • Power supply/external device side: discrete wire	2 m	DOL-1204-G02M
		5 m	DOL-1204-G05M
 Branch connector	Branch connector for connecting sensor heads and various cables. Included with sensor head.	-	SYL-1208-G0M

■ Amplifier unit, connector cables for amplifier unit

Type	Specifications	Cable length	Model
 Amplifier unit	An amplifier unit to which up to two sensor heads can be connected. Control can be performed using either analog or control outputs, while thickness and height difference measurements can be performed using two sensor heads.	2 m	CDA-M
 Sensor/amplifier connection cable	Connector cable for connecting branch connectors and amplifier units. Robot cable specifications. • Branch connector side: M12, 5-pin socket • Amplifier unit side: M8, 4-pin plug	2 m	DSL-1204-G02M
 Sensor-to-amplifier extension cable	Extension cable for connection to DSL-1204-G02M. Robot cable specifications. • Sensor/amplifier connection cable side: M8, 4-pin socket • Amplifier unit side: M8, 4-pin plug	2 m	DSL-0804-G02M
		5 m	DSL-0804-G05M

- Please ensure that the overall cable length when an amplifier unit is used is within 10 m (sensor head extension cable + sensor/amplifier connection cable + sensor-to-amplifier extension cable).
- If using an amplifier unit, some settings for the CDX series cannot be confirmed or changed. For details, see the CDX series user's manual.
- On the CDX series, CH1 is the only output that can be set and used with an amplifier unit.
- The CDX series does not support CC-Link communication.
- The resolution of the analog outputs (shown below) will be lower than that when using Ethernet communication.
 CDX-85A/-W85A: 10 µm, CDX-150A/-W150A: 10 µm

System Configuration

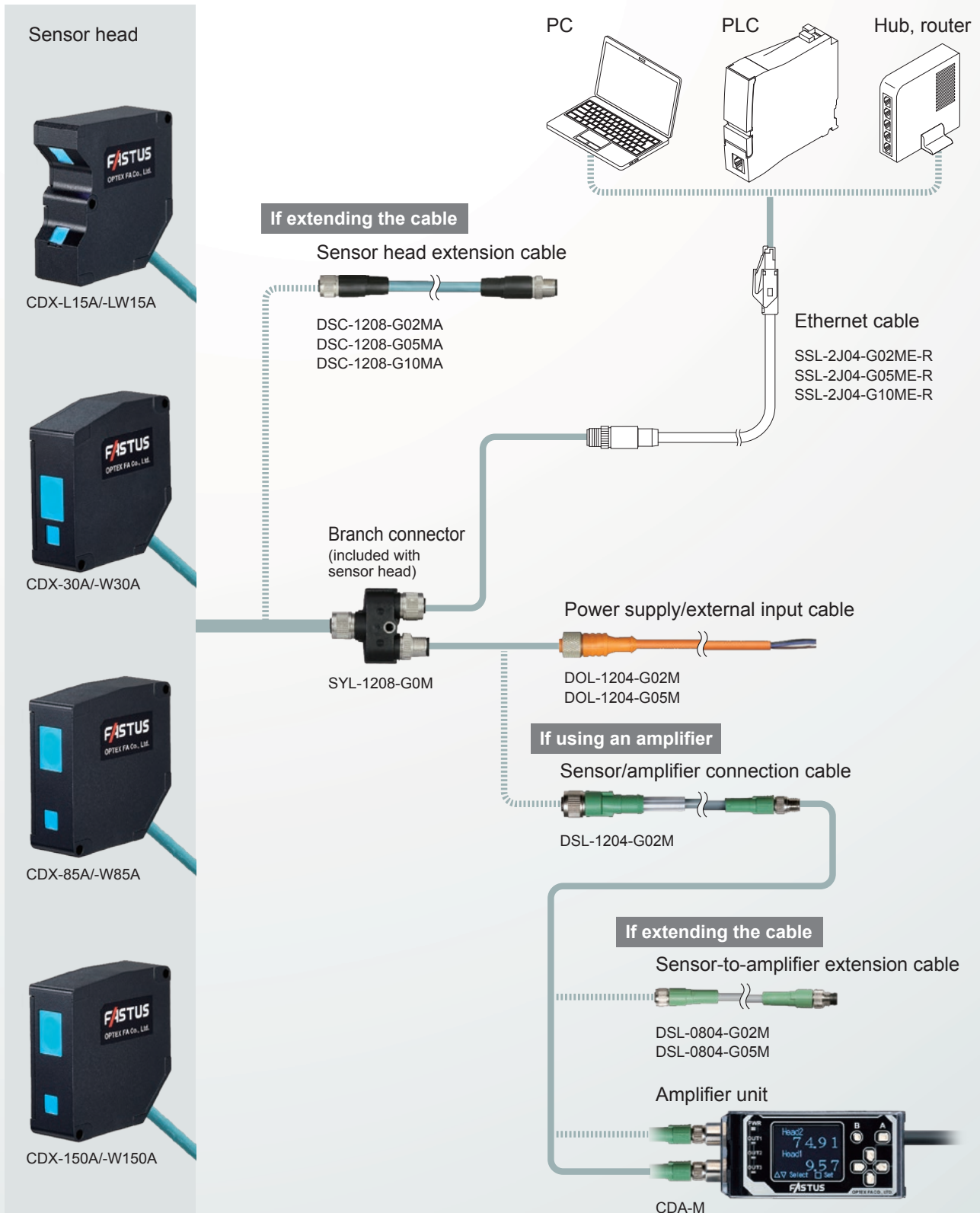

Specifications

■ Sensor head (model based specifications)

Model	CDX-85A		CDX-W85A		CDX-150A	CDX-W150A
Optical method	Diffuse installation	Specular installation	Diffuse installation	Specular installation	Diffuse installation	
Measurement range ^{*1}	85 +/-20 mm	81.5 +/-10.0 mm	85 +/-20 mm	81.5 +/-10.0 mm	150 +/-40 mm	
Light source	Medium	Red semiconductor laser				
	Wavelength	655 nm				
	Maximum output	0.39 mW				
Laser class	JIS/IEC	Class 1				
	FDA ^{*2}	Class 1				
Spot size ^{*3}	ø70 µm		70 × 2000 µm		ø120 µm	120 × 4000 µm
Linearity	Meas. range 65 to 85 mm: +/-0.018% of F.S. (+/-7.2 µm) Meas. range 85 to 105 mm: +/-0.03% of F.S. (+/-12.0 µm)	+/-0.03% of F.S. (+/-6.0 µm)	+/-0.015% of F.S. (+/-6.0 µm)	+/-0.03% of F.S. (+/-6.0 µm)	Meas. range 110 to 150 mm: +/-0.03% of F.S. (+/-24 µm) Meas. range 150 to 190 mm: +/-0.04% of F.S. (+/-32 µm)	+/-0.015% of F.S. (±12 µm)
Resolution ^{*4}	0.3 µm					
Repeat accuracy ^{*5}	0.3 µm					
Sampling period	12.5 µs / 25 µs / 50 µs / 100 µs / 200 µs / 500 µs / 1 ms / Auto					
Temperature drift	+/-0.01% F.S./°C (at -10 to +40°C), +/-0.03% F.S./°C (at +40 to +50°C)					
Weight	Approx. 280 g (including 500 mm connector cable)					

Measurement conditions The measurement conditions are as follows unless otherwise designated:
Ambient temperature: 25°C (normal temperature), Supply voltage: 24 VDC, Sampling period: 25 µs, Moving average performed: 256, Median filter: 31, Center of measurement range, Measurement target (specular reflection: aluminum deposition mirror, diffuse reflection: visible light shielding ceramic).

*1. The measurement range will become narrower when the sampling period is set to the maximum speed of 12.5 µs. Please use by selecting from Near/Center/Far below.

Model		Measurement range		
		Near	Center	Far
CDX-85A/-W85A	Diffuse installation	65.0 to 77.7 mm	73.5 to 90.8 mm	84.8 to 105.0 mm
	Specular installation	71.5 to 74.3 mm	70.6 to 86.9 mm	81.0 to 91.5 mm
CDX-150A/-W150A		110.0 to 134.4 mm	124.8 to 166.3 mm	150.2 to 190.0 mm

*2. In accordance with the FDA provisions of Laser Notice No. 50, the laser is classified as Class 1 per the IEC 60825-1:2007 standard.

*3. Defined with center strength $1/e^2$ (13.5%) at the center of measurement range. There may be leak light other than the specified spot size.

The sensor may be affected when there is a highly reflective object close to the detection area.

*4. The minimum step that can be identified when the distance between the sensor and target changes one step at a time (when performing moving average 65,536 times)

*5. Peak-to-peak value of measured value when measuring in stationary state (when performing moving average 65,536 times)

■ Sensor head (common specifications)

Supply voltage	12 to 24 VDC (+/-10%, including ripple)	
Current consumption	180 mA (at 24 VDC)	
Communication interface	Ethernet (100BASE-TX) / Corresponding to IEEE1588	
External input	Selectable from laser OFF, hold/reset, start storage, and offset	
Indicators	Link indicator (green) / power indicator (orange/green/blue/red)	
Degree of protection	IP67 (including connector part)	
Ambient temperature/humidity	-10 to +50°C / 35 to 85% RH (no condensation or freezing)	
Storage temperature/humidity	-20 to +60°C / 35 to 85% RH (no condensation or freezing)	
Ambient illuminance	Incandescent lamp: 3,000 lx or less, fluorescent lamp: 10,000 lx or less	
Vibration resistance	10 to 55 Hz; double amplitude 1.5 mm; 2 hours in each of the X, Y, and Z directions	
Shock resistance	50 G (500 m/s ²), 3 times in each of the X, Y, and Z directions	
Applicable regulations	EMC	EMC directive (2014/30/EU)
	Environment	RoHS directive (2011/65/EU), Battery directive (2006/66/EC), China RoHS (Directive No. 32)
	Safety	FDA regulations (21 CFR 1040.10 and 1040.11) ^{*6}
Applicable standards	EN 60947-5-2:2007 / A1:2012, IEC 60825-1:2007 and 2014	
Warm-up time	Approx. 30 minutes	
Material	Housing: Aluminum die-cast, Optical window: Glass	

*6. Excluding differences per Laser Notice No. 50.

Dimensions

(Unit: mm)

■ CDX-85A/-W85A (Diffuse installation)

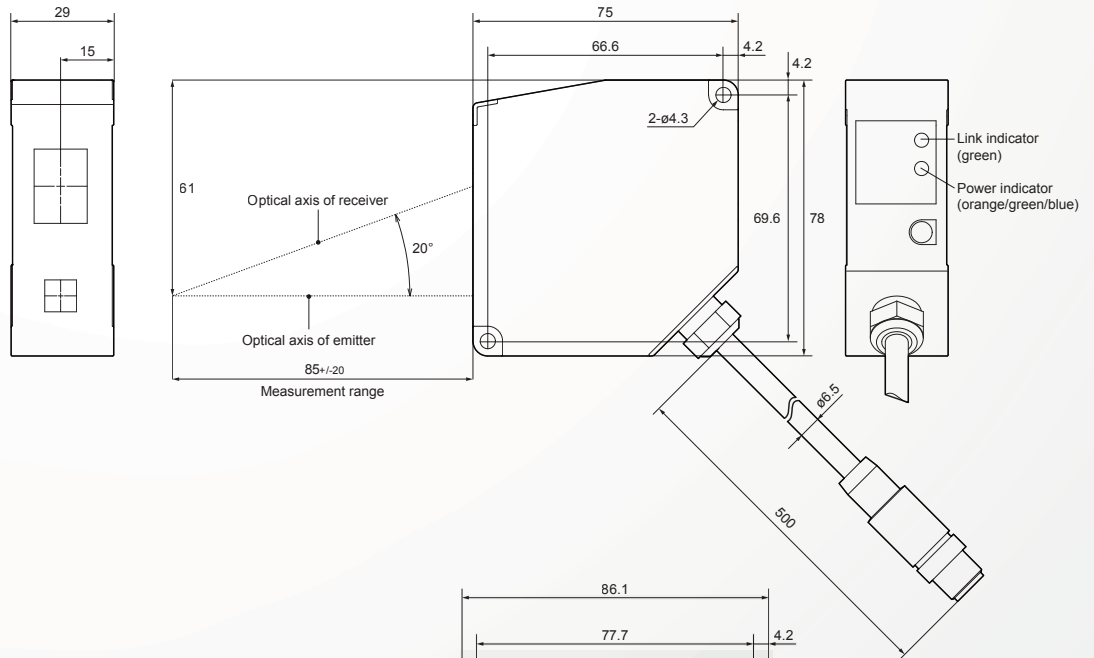

(Specular installation)

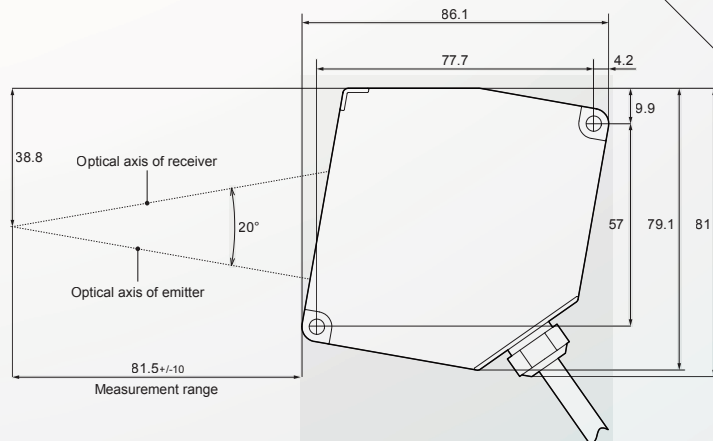

■ CDX-150A/-W150A

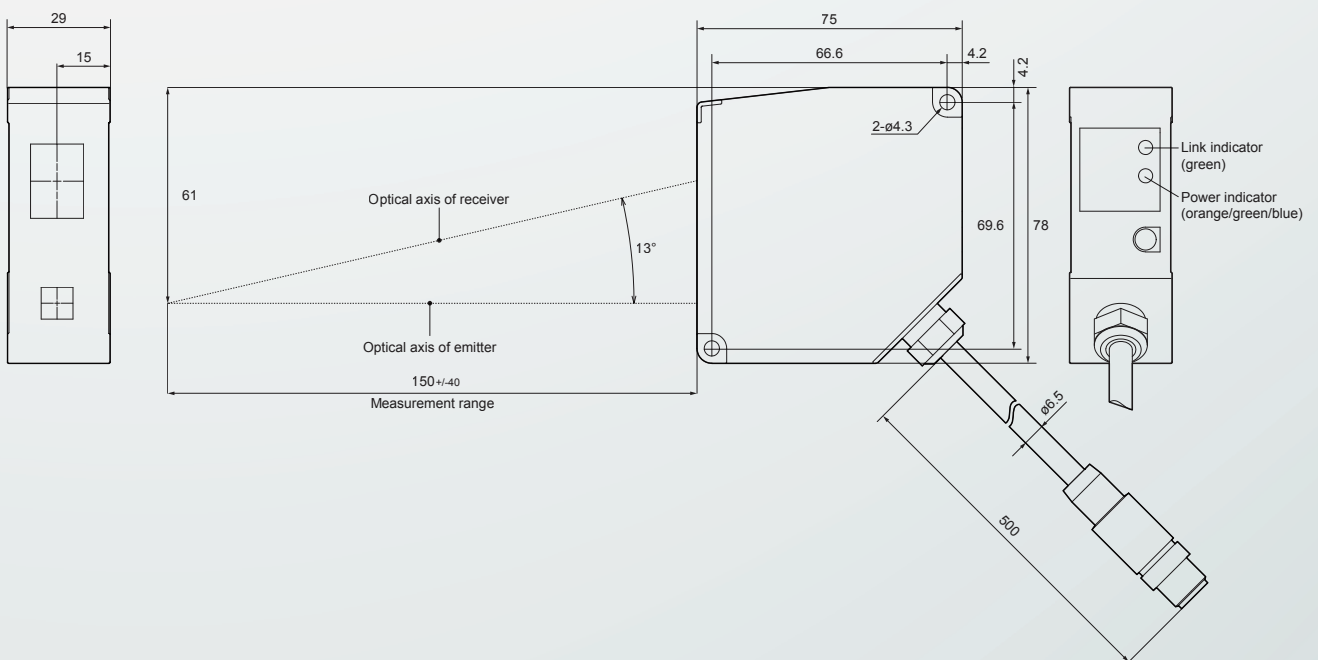

Dimensions

(Unit: mm)

■ SYL-1208-G0M

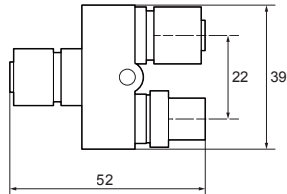

■ CDA-M

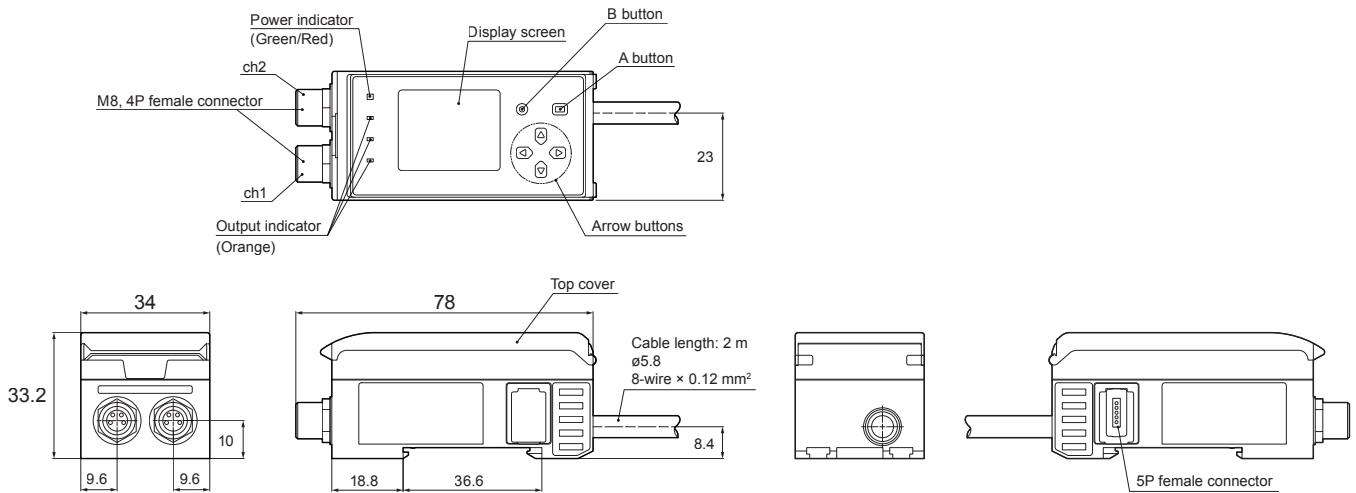

■ Regarding applicability of Export Trade Control Order enacted by Japanese government for the CDX series

Caution

CDX series sensor heads are products that are subject to "Export Trade Control Order Appended Table 1 2-(12) Measurement devices (including machine tools with a measurement function)". Please inquire for details.

Model	Measurement mode	Resolution	
		Sensor head only	With amplifier unit
CDX-85	Diffuse mode	0.1 μm	10 μm
	Specular mode		
CDX-W85	Diffuse mode		
	Specular mode		
CDX-150	Diffuse mode	0.2 μm	
CDX-W150	Diffuse mode		

Additional information

There is no differentiation for the applicability of CDA series amplifier units and the resolution outputted from amplifiers connected to sensor heads is regulated as shown in the table to the left even if the average number of cycles is increased.

Attention: Not to be Used for Personnel Protection.

Never use these products as sensing devices for personnel protection. Doing so could lead to serious injury or death. These sensors do not include the self-checking redundant circuitry necessary to allow their use in personnel safety applications. A sensor failure or malfunction can cause either an energized or de-energized sensor output condition. Please consult our distributors about safety products which meet OSHA, ANSI and IEC standards for personnel protection.

- Specifications are subject to change without prior notice.
- Specifications and technical information not mentioned here are written in Instruction Manual. Or visit our website for details.
- All the warnings and cautions to know prior to use are given in Instruction Manual.



OPTEX FA CO., LTD.

91 Chudoji-Awata-cho Shimogyo-ku Kyoto 600-8815 JAPAN
 TEL. +81-75-325-1314 FAX. +81-75-325-2936
<http://www.optex-fa.com>