

Linear-Transducer LA66K - ISI

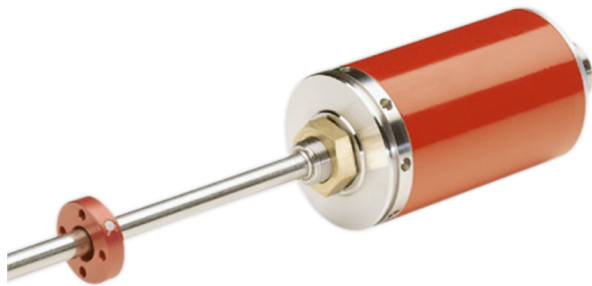

Ref.: K-LA66-ISI-1

18.11.2013

0102010060

Advantages

- _ Customer-specific solutions
- _ Flexible programming
- _ Further interfaces available
- _ Measures linear movements
- _ Perfect fit for cylinders
- _ Pressure proof tube housing
- _ Wear-free detection

General Data

Supply	
- Supply voltage	24 VDC, -20...+10 %
Current consumption no load	<= 250 mA
Measuring principle	magnetostrictive
Measuring length, standard	150...3000 mm, in steps
Resolution	0.01 mm
Linearity deviation	< 0.05 %
Reproducibility	0.01 mm
Hysteresis	0.1 mm
Temperature coefficient	< 8 $\mu\text{m}/^\circ\text{C}$ <= 500 mm < 15 ppm/ $^\circ\text{C}$ > 500 mm
Straight line velocity	1 m/s, Resolution = 0.01 mm
Mounting position	no restrictions
Material - Measuring body	Cr/Ni - alloy
Rod end mounting	Option
Magnet	T4-M33 other on request
Incremental - Interface	
- Load frequency	4...120 kHz
- Incremental signals	K1 \pm K2 \pm
- Output driver, TTL	RS-422, 5 VDC

Subject to change.

TR-Electronic GmbH
Eglisshalde 6
78647 Trossingen
Tel. +49 (0) 7425 228-0
info@tr-electronic.de
www.tr-electronic.de

Linear-Transducer LA66K - ISI

Ref.: K-LA66-ISI-1

18.11.2013

0102010060

General Data continuation

- Output driver, HTL	Push-Pull, 11...27 VDC
Parameter/Function, changeable	Resolution
	Load frequency
	Preset parameter
	Counting direction
Type of parametrization	programmable
Prgramming - Tool	TR-Tool: PT-100-N
Cycle time, internal	see dimensional drawing
External inputs	
- Preset	electronic adjustment
- Load input	Load absolute position
- Logic level	"0" < +2V, "1" = Supply
External outputs	
- Load output	ISI Load process finished

Environmental conditions

Vibration	
- Specific value	$\leq 100 \text{ m/s}^2$
- Sine	50...2000 Hz
Shock	
- Specific value	$\leq 1000 \text{ m/s}^2$
- Half sine	11 ms
Immunity to disturbance	DIN EN 61000-6-2
Transient emissions	DIN EN 61000-6-3
Working temperature	
- Standard	0...+70 °C
- Optional	-20...+70 °C;
Storage temperature, dry	-30...+85 °C
Relative humidity	98 %, non condensing
Protection class	
- Standard	IP65
Stray magnetic field	< 3 mT
Measuring reference	Measuring plane
Pressure resistance	
- Optional	600 bar, static

Subject to change.

Linear-Transducer LA66K - ISI

Ref.: K-LA66-ISI-1

18.11.2013

0102010060

Dimensional drawing

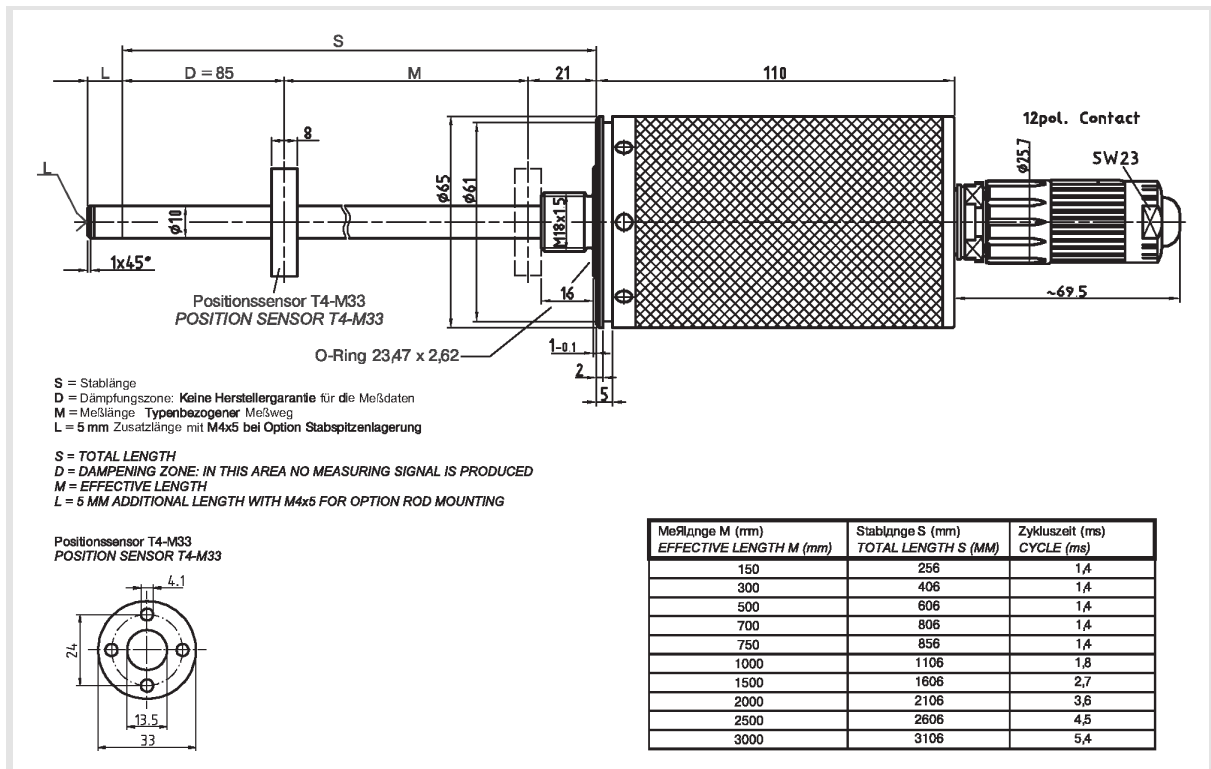

Subject to change.