

Basic Information Before Use

1

Display on LCD Screen

2

Teaching Work

3

Changing Set Value

4

Troubleshooting

5

Appendix

6



- This Instruction Manual is for the color vision sensor series Color Identity Sensor (CVS1).
- Carefully read this manual before using this device for correct use.
- After reading this manual, keep it handy for ready reference.
- This device cannot be used as a safety-related device to protect human body.

Meanings of Safety Symbols

In this manual, various symbols are used for safe use of the device, preventing the harm to you and other persons as well as the damage to the property.

Symbols and their meanings are as follows. Before reading this manual, fully understand the meanings of these symbols.



WARNING

Indicates a possible hazard that may result in death or serious injury if the device is used incorrectly without observing stated instructions.



CAUTION

Indicates a possible hazard that may result in any injury or property damage if the device is used incorrectly without observing the stated instructions.



Indicates precautions and regulations to be observed or other information useful to know.

PRECAUTIONS FOR SAFE USE



- Do not disassemble nor modify the device. Otherwise, it may cause a fire or an electric shock.
- Continuing to use the device under abnormal conditions, such as those with abnormal smell or smoke, may cause a fire or an electric shock. In such cases, immediately pull out the power plug and confirm that the abnormal condition is removed, and then contact us or our sales representative. Never repair the device by yourself since it is dangerous.
- Do not use the device by a power voltage outside 12-24 V DC. It may cause a fire or an electric shock.
- Avoid wiring a cable and high-voltage or power cable in parallel or wiring them in a same piping. It may cause a malfunction of the device.
- Do not mount the device at any one of the following places to use this product properly and safely. If not observed, it may cause a fire, an electric shock, or a failure.
 - Place at high prospective humidity
 - Place at high prospective temperature (where the device is subject to direct sunshine)
 - Dusty place
 - Place with insufficient ventilation
 - Place where static electricity is likely to be generated
 - Place involving corrosive or flammable gases
 - Place where the device is subject to water, oil, and /or chemical splashes
 - Place with direct vibration and impact
- Do not handle electric cables as follows. Otherwise, cables may be damaged, resulting in a fire or an electric shock.
 - Damage
 - Torture
 - Pull
 - Twist
 - Bundle,
 - Put heavy stuff
- Do not touch the device or its cable with wet hand. Otherwise, it may cause an electric shock.



- Do not insert any improper cable or metal into electrical terminals. It may result in short-circuiting inside the device, causing a fire, an electric shock, and / or a failure.
- Do not drop this device nor give any strong impact on it. It may result in personal injury, if it falls on your foot, or a device failure.



- Securely mount this device. This device may fall off due to insufficient mounting or unstable mounting position, resulting in personal injury or an accident.
- Wipe off the dirt on this device with a soft, dry cloth or a firmly squeezed cloth wet with diluted neutral detergent.
- Please note that there may be dead pixels or bright pixels with the LCD screen although it has been produced with a super-high precision technology.

TABLE OF CONTENTS

FORWARD	2
Meanings of Safety Symbols	2
PRECAUTIONS FOR SAFE USE	3
TABLE OF CONTENTS	5
1 BASIC INFORMATION BEFORE USE.....	6
Names and Functions of Components	6
Precautions When Mounting the Sensor	7
Wiring of Power Cable.....	9
Options	9
2 DISPLAY ON LCD SCREEN	10
Outline of LCD screen	10
Details of LCD Screen.....	11
Names and Functions of Operating Buttons.....	12
3 TEACHING WORK	13
Outline of Teaching	13
1-point Teaching.....	14
2-point Teaching.....	18
Upper / Lower Limit Teaching.....	20
4 CHANGING SET VALUE	23
Set Value Change Method	23
Example of Changing Set Value.....	24
Set Items List.....	25
5 TROUBLESHOOTING	30
When A Trouble Has Occurred	30
Technique When Teaching cannot be Done Correctly.....	41
6 APPENDIX.....	45
Specifications	45
Dimensions Drawing.....	46
Operation Check By Using A Sample.....	46
Index.....	47
Warranty	48

1 BASIC INFORMATION BEFORE USE

Confirm that the device is not damaged before using it.

Names and Functions of Components

Operating Buttons

Use to set for teaching, etc., set each item, or switch the display mode of the screen.

☞ See "Names and Functions of Operating Buttons" on Page 12.

LCD Screen

Displays the images and the detection result taken by the built-in camera. Also, displays each set item and set value.

☞ See "Display on LCD Screen" on Page 10.

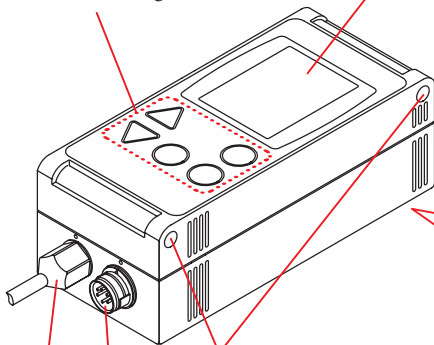

Mounting Hole

A hole to mount this device
Using a screw M4 × 50 mm or more is recommended.

☞ See "Dimensions Drawing" on Page 46.

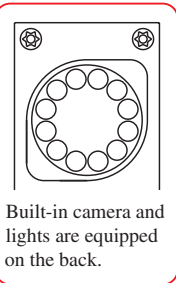

Built-in camera and lights are equipped on the back.

Cable Connector

Connects external cable (Option).

☞ See "Options" on Page 9.

Power / Signal Cable Connector

Connects the power / signal cable.

☞ See "Wiring of Power Cable" on Page 9.

Precautions When Mounting the Sensor

- Mount the sensor leaned by 5° - 45° so that lighting should not be reflected by a work.

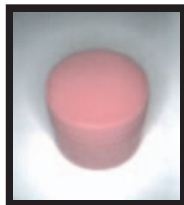
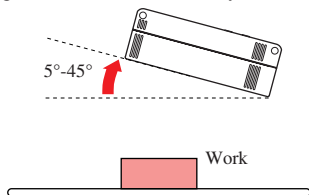

1

- Detection may become successful by changing the setting even if a detected image is displayed as shown in the right figure.

☞ See "Technique When Teaching cannot be Done Correctly" on Page 41.

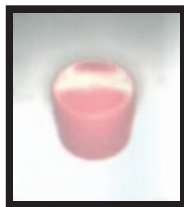

When a work is shiny, tilt the sensor by 10° - 40° to avoid the mirror reflection.

- Take caution so that the external lighting (light from fluorescent light, etc.) is not reflected.



- The area changes depending on the distance between the sensor and a work. Give such machinery configuration that it can keep constant distance if a precise area setting is necessary for the detection of a work.
- Refer to the standard object distance of each model as to the distance between this sensor and a work.
 - ☞ See "Specifications" on Page 45.If the object distance is too near, the sensor becomes out of focus, causing an irregular lighting, while it is too far, the sensor is likely to receive the influence of the turbulence light since the light does not reach the work.
- When a work moving very fast is going to be detected, the shutter time (brightness) has to be shortened. In such a case, make the distance between the sensor and a work closer or add additional external lighting since quantity of light becomes insufficient with only the built-in light in this sensor.
 - ☞ See "Options" in Page 9.
- The shutters of the image sensor of this device open in sequence from the right to the left in the screen. For this reason, the work moving from the right to the left is displayed wider and the one moving opposite is displayed narrower.
- Please note that there may be dead pixels (pixels that cannot receive light correctly) with this image sensor. Although dead pixels may not detect or detect incorrectly, they will not be any problem on the practical use since they are very few.

Wiring of Power Cable

The following shows the color and signal allocations of the power / signal cable lines.

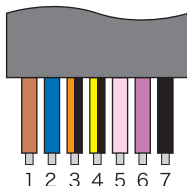

No	Line Color	Content of signal
1	Brown	12-24 V DC
2	Blue	0 V
3	Orange / Black	Bank switch 0
4	Yellow / Black	Bank switch 1 / Lower limit output
5	Rose	Bank switch 2 / Teach input
6	Purple	Bank switch 3 / Synchronous input
7	Black	Output



- The LCD screen and lighting turn ON when the power lines are connected.
- Note that the required power capacity is 300 mA per unit as a standard guideline.

Options

The following options can be connected to this device.

Model	Application
CVS-M1* Remote Monitor	Monitoring unit furnished with the remote control function for the color vision sensor series. Connected to see the detection result at a place remote from the work. Also, teaching and various settings are possible as done with this device.
CVS-LW1* External Lighting (white)	One-touch connected external lighting unit for the color vision sensor series; Use this lighting where this sensor is mounted at a dark place and stable result is not obtained due to insufficient lighting.
CVS-C3S Extension Cable (3 m)	Extension cable for the remote monitor. Four cables can be connected at maximum for extension (15 m in total).

* Patent being applied



- Three external lightings and one remote monitor can be connected per one unit of this device.
- When a remote monitor is connected, the LCD screen of this device turns OFF to decrease the internal heat generation if no operation is made on this device for 60 seconds. The LCD screen turns ON again when any one of the operating buttons of this device is pressed.

2 DISPLAY ON LCD SCREEN

Outline of LCD screen

The display mode of the LCD screen can be switched.



Normal screen

"Normal screen" is first displayed when the device is powered ON.

Keep the device in this mode during the normal operation.



Press .



Set Value Reference screen

The display is switched to the "Set Value Reference screen."

This is the mode to display set values.



Press  for 3 sec. or more.

Set Value Change screen

The display is switched to the "Set Value Change screen."

The set value of each set item can be revised in this screen.  See "Changing Set Value" on Page 23.

Details of LCD Screen

This section describes the details of the contents displayed on the LCD screen.

Normal screen

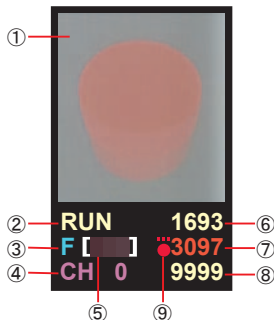

Set Value Reference screen Set Value Change screen



- ① Image screen
The image taken by the built-in camera is displayed.
- ② Mode display
"RUN" is displayed in the Normal screen.
- ③ Screen display status
Shows the display status when the display mode is switched with  button.
☞ See "Detection color is not clear. How is it confirmed?" on Page 40.
- ④ Bank number
Present bank number is displayed. (0-15)
- ⑤ Detection color
Detection color is displayed.
Indicates "Darkest color," "Middle color," and "Brightest color" from the left.
- ⑥ Area lower limit
Indicates the area lower limit of the detection color.
- ⑦ Detection color area
Indicates the present area of the detection color.
Orange: within upper and lower limits
Green: Outside upper and lower limits
(Status with area hysteresis excluded)
- ⑧ Area upper limit
Indicates the area upper limit of the detection color.
- ⑨ Output condition
●: Output ON ✖: Output OFF

In the Set Value Reference screen and the Set Value Change screen, the contents of ②, ⑥, and ⑧ will change as follows. ☞ See "Changing Set Value" on Page 23.

②→⑩ Set item ⑥→⑪ Set value ⑧→⑫ Response time (Unit: 0.1 ms)

Names and Functions of Operating Buttons

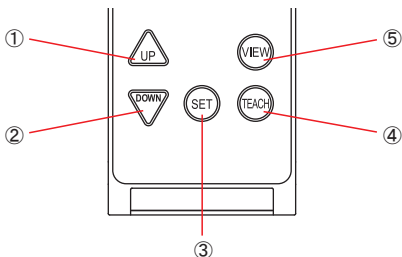

① UP button

Use to increase a set value, etc. or change a set item.

② DOWN button

Use to decrease a set value, etc or change a set item.

③ SET button

Use to display a set value.

Press for 3 seconds or more to enter a revised set value.

④ TEACH button

Press for 3 seconds or more for teaching.

Also, used to move the teaching window or change its size.

☞ See "Teaching Work" on Page 13.

⑤ VIEW button

Use to switch the display mode of the screen.

☞ See "Detection color is not clear. How is it confirmed?" on Page 40.

3 TEACHING WORK

The teaching function of this device brings a stable result by a simple setting even when a work to be detected is complex in shape or when only an unstable result is obtained with a photoelectric sensor. (Note that the output is interrupted during teaching.)

A work sample is available at the back in this manual.

☞ See "Operation Check By Using A Sample" on Page 46.

Outline of Teaching

Specify only the part (area) of a work to be detected, and teach the color of the specified portion only.

Works are distinguished by the difference in the detected color.

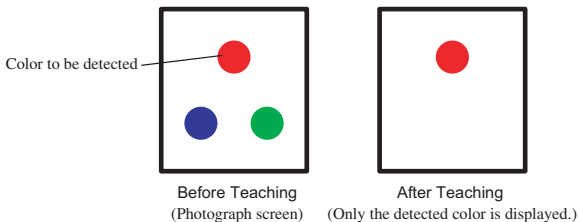

- Measuring time is shortened and malfunction by unnecessary portions is prevented by imaging only the necessary part. ☞ See Step 6 "Expanding only the teaching window section" on Page 17 in "1-point Teaching."
- The detection area can be set per every bank (16 banks at maximum) and they can be detected being switched.
- The colors not selected by teaching will be black (or white) so that you can confirm whether or not the detection color is mis-recognized.

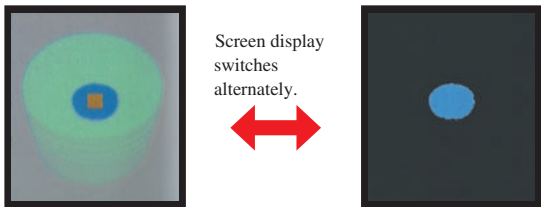

1-point Teaching

By teaching a work to be detected, a half of the area of the specified color is automatically set as the lower limit (with upper limit 9999 at maximum). The detection range of the area falls into somewhere between the upper and lower limits.



- Set the area upper limit (AREA HI) to "0." Also, note that the set value is different in each bank.
- The taught upper and lower limits can be changed later.
☞ See "Change Set Value" on Page 23.

1 Press in the normal screen for 3 seconds or more.

The display is switched to the Teaching Setting screen.

Explanation of Teaching Setting screen

(or teaching window) blinks at the center in the screen.
Colors between the brightest and the darkest inside the teaching window are treated as the detection colors.

Set item is displayed.
TEACH1 shows the 1-point teaching is being proceeded.

The color in the teaching window is displayed. The "darkest color," "middle color," and "brightest color" are shown in sequence from the left.

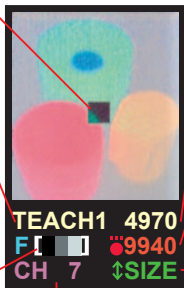

Bank number being set is displayed.

The lower limit is displayed. A half of the selected color area becomes the lower limit. It becomes $9940/2=4970$ for the screen.

Selected color area is displayed.

The items for which the shape, color, etc. of the teaching window can be changed are displayed.
☞ See Steps 2-6.

- 2** Confirm the **↓SIZE** display is displayed.
 (Press  several times if a different display is displayed.)

Set the vertical size of the teaching window.

- ① Every pressing  will increase the vertical size.

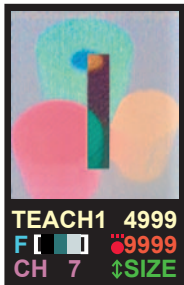

- ② Every pressing  will decrease the vertical size.

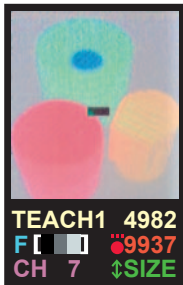

- 3** Display **↓MOVE** by pressing .

Set the vertical position of the teaching window.

- ① Every pressing  will move the position upward.



- ② Every pressing  will move the position downward.

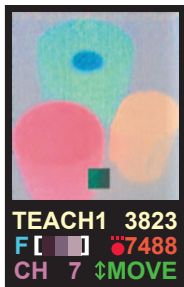

4 Display **↔SIZE** by pressing .

Set the horizontal size of the teaching window.

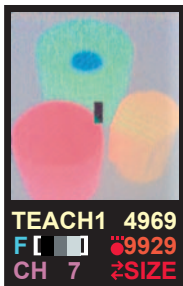
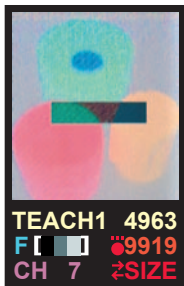

- ① Every pressing  will increase the horizontal size.
- ② Every pressing  will decrease the horizontal size.



Colors within a narrower area can be correctly recognized by reducing the size of the teaching window.

5 Display **↔MOVE** by pressing .

Set the horizontal position of the teaching window.

- ① Every pressing  will move the position to the right.
- ② Every pressing  will move the position to the left.

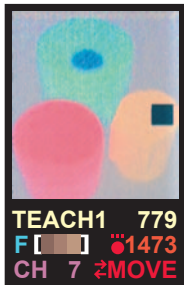

6 Display **ZOOM** by pressing **TEACH**.

Make this setting when taking an image, expanding only the teaching window section.

① Set the size and the position by the former steps 2-5.

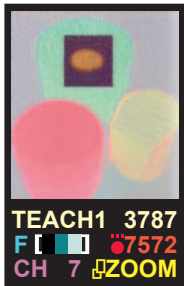

② Pressing **UP** will zoom in the display.



- Pressing **DOWN** will return to the whole display.
- The normal screen is zoomed in as well when the display is zoomed in.

7 Press **SET** for 3 seconds or more.

Teaching will complete, and the display will return to the normal screen.

- Pressing **TEACH** for 3 seconds or more will return the display to the normal screen without completing teaching.
- In the Teaching Setting screen, every pressing **TEACH** will switch the set change item of the teaching window as follows.



- Steps 2-6 can be repeated until **SET** is pressed for 3 seconds or more in Step 7.
- 2-point teaching (☞ See Page 18.) is selected when **SET** is not pressed for 3 seconds or more. Press **SET** to return to 1-point teaching.

2-point Teaching

The area value of the detecting color becomes greater even when there is no work if the color of the work is similar to the background. In such a case, set the area of the background color as the lower limit by using the 2-point Teaching method.

When there is a work

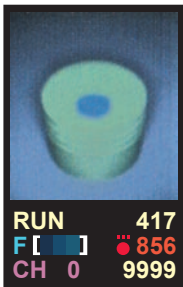

When there is no work

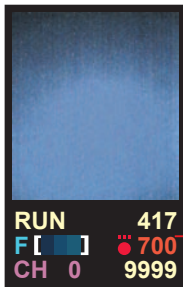

Area value is great even if there is no work.



Set the area upper limit (AREA HI) to "0." Also, note that the set value is different in each bank.

1 First of all, teach the 1st point.

☞ Perform the operations in Step 1-6 in "2-point Teaching" on Page 14.

Display shows that teaching (for 1st point) is being proceeded.

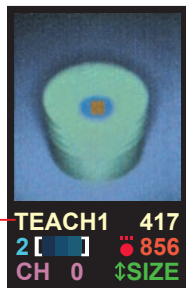

2 Press .

Teaching is switched to the setting for the 2nd point.



Pressing  for 3 seconds or more will restore the normal screen, canceling teaching.

3 Remove the work.

Confirm that the set item is changed to "TCH LOW" from "TEACH1."

Display shows that teaching (for 2nd point) is being proceeded.

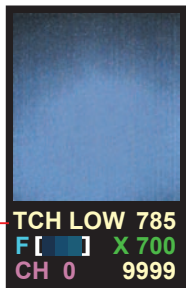



3

4 Press for 3 seconds or more.

Teaching will complete, and the display will return to the normal screen.



- Pressing  for 3 seconds or more will return the display to the normal screen without completing teaching.
- Pressing  will restore the setting for 1st point from that for the 2nd point.

Upper / Lower Limit Teaching

Teach the works for the upper and lower limits of the area to be detected. The area range between the taught upper and lower limits will become the area detection range.

Upper limit work



Lower limit work

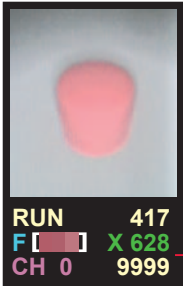

Upper limit

Lower limit

The range in-between becomes the detection range.

The image shows two side-by-side displays. The left display, labeled 'Upper limit work', shows a red area on a grey background. Below it, the text reads 'RUN 900', 'F [] 1546', and 'CH 0 9999'. A red box labeled 'Upper limit' points to the '1546' value. The right display, labeled 'Lower limit work', shows a smaller red area. Below it, the text reads 'RUN 417', 'F [] X 628', and 'CH 0 9999'. A red box labeled 'Lower limit' points to the '628' value. A larger red box at the bottom contains the text 'The range in-between becomes the detection range.' with lines pointing to the '1546' and '628' values.

Set the area upper limit (AREA HI) to "1 or more" before starting the upper / lower limit teaching.



Note that the set value is different in each bank.

1 Press in the normal screen.

The display is switched to the Set Value Reference screen.

2 Press until the area upper limit "AREA HI" is displayed.

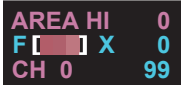

AREA HI 0
F [] X 0
CH 0 99

The image shows a black display with white and red text. The text is arranged in three lines: 'AREA HI 0', 'F [] X 0', and 'CH 0 99'.

3 Press for 3 seconds or more.

The display is switched to the Set Value Change screen.

Indication changes into red.

AREA HI	0
F [] X	0
CH 0	99

4 Make the set value to "1" by pressing .

AREA HI	1
F [] X	0
CH 0	99

5 Press for 3 seconds or more.

The set value is entered, restoring the Set Value Reference screen.

Set the area upper limit (AREA HI) to "1" and perform the 2-point teaching. Then, the 1st point is set as the upper limit and the 2nd point is also set as the lower limit by the teaching.

6 At first, set the work for the upper limit, and teach it as the 1st point.

 Perform the operations in Steps 1-6 of "1-point Teaching" on Page 14.

Display shows that teaching (for the 1st point) is being proceeded.

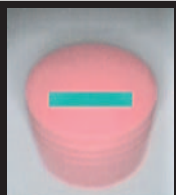

TEACH1	3050
F [] X	X2876
CH 0	↓SIZE

7 Press .

Teaching item is switched to the setting for the 2nd point.



Pressing  for 3 seconds or more will restore the normal screen, canceling teaching.

8 Set the work for the lower limit, and teach it as the 2nd point.

Confirm the setting item is switched to "TCH LOW" from "TEACH1."





The display shows that teaching (for the 2nd point) is being proceeded.

9 Press for 3 seconds or more.

The teaching is completed, and the display will return to the normal screen.



- Pressing  for 3 seconds or more will return the display to the normal screen without completing teaching.
- Pressing  will restore the setting for the 1st point from that for the 2nd point.

4 CHANGING SET VALUE

The set values for detection can be changed fine according to the condition of the work to be detected and the environment of the line where this device is mounted.  See "Setting Items List" on Page 25.

Also, the set values can be locked so as not to be changed by mistake (Change prohibition).  See "Set value cannot be changed." on Page 35.

Set Value Change Method

1 Press in the normal screen.

The display is switched to the Set Value Reference screen.



Set item

Set value

2 Display an intended set item by pressing or .



Set value changes into red.

3 Press for 3 seconds or more.

The display is switched to the Set Value Change screen.



4

4 Change the set value by pressing or .

 : Every pressing will increase a value by "1."

 : Every pressing will decrease a value by "1."



5 Press for 3 seconds or more.

The revised set value is entered, restoring the Set Value Reference screen. Pressing  will return the display to the Set Value Reference screen, canceling the revised set value.



6 Press .

The display will return to the normal screen.

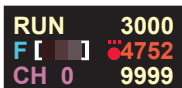

Example of Changing Set Value

The following is an example of adjusting the brightness of the work.
(Normally, the brightness is set optimally by teaching.)

When screen is dark



The set value of BRIGHT (screen brightness) is small.



Press  to increase the set value.

When work is bright

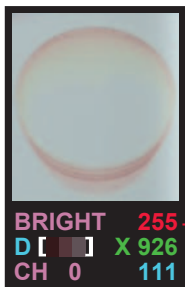

The set value of BRIGHT (screen brightness) is great.



Press  to decrease the set value.

Set Items List

The following table shows the functions, the setting range, and the initial values of the set items whose settings are changeable.

Function name LCD display	Setting range (Initial value)	Explanation
Area lower limit* ¹ AREA LO	0 – 9999 (5000)	Sets the lower limit of the detection area. Sets the set value of MAXAREA as the maximum value.
Area upper limit* ¹ AREA HI	0 – 9999 (0)	Sets the upper limit of the detection area. Sets the set value of MAXAREA as the maximum value. The maximum value (the set value of MAXAREA) is set as the upper limit when set to "0" and only the lower limit is set by teaching. The set value is set as the upper limit when set to "1 or more" and both the upper and lower limits can be taught by teaching.
Bank selection BANK	0 – 17 (17)	Sets the method to switch the bank number. 0 – 15 : Selects the set bank. EXTEACH input is effective. 16 : Switches the bank by an external input. (Bank switch 2 input is invalid, and the teach input is effective.) 17 : Switches the bank by an external input. (Bank switch 2 input is effective, and the teach input is invalid.)
Screen brightness* ^{1, 2} BRIGHT	0 – 255 (100)	Sets the brightness of the whole screen. Normally set to an optimal set value at teaching (→ TEACHMD)
Color margin* ¹ COLOR%	0 – 127 (20)	Sets the margin when the detection color is set as the representative value. Each detection color \pm set value becomes the upper and lower limits of each detection color* ³ .

*1: Set value changes when the bank is switched.

*2: Note that brightness does not increase even if set over the horizontal resolution.

*3: The detection color is internally processed by a value within 0 – 255.

Function name LCD display	Setting range (Initial value)	Explanation
Color filter*4★ COLRFIL	0 – 3 (0)	Sets the color filter. 0 : Converts the color ratio per each pixel. 1 : Acquire the maximum luminance (brightest point) according to RGB in the four right – most columns, and correct the brightness of each pixel by the value. Used only when detecting the difference in the color shades such as the difference between black and gray, etc. 2 : High sensitivity mode of "0." Used to shorten the shutter time. 3 : High sensitivity mode of "1." Used to shorten the shutter time.
Area hysteresis HYSTRSY	0 – 200 (10)	Sets the hysteresis (0.1% unit of all pixels) of the area upper and lower limits. When the area immediately before detection is within the detection area range, the value obtained by adding the set value to the area upper limit number of pixels and the value obtained by subtracting the set value from the area lower limit number of pixels become the area upper and lower limits respectively.
Input constant IN FILT	0 – 4 (4)	Sets the time constants of the bank switching signal and the external teaching signal. 0 : 128 – 192us 1 : 2 – 3ms 2 : 4 – 6ms 3 : 6 – 9ms 4 : 8 – 12ms
Darkness correction factor*1★ KIL_BLK	0 – 31 (27)	Sets the ratio to correct the color darkness. Any correction is not made when set to "0" and the maximum effect (to amplify "black" to convert to other color) is obtained when "31" is set. Greater set value is likely to make a darker color a noise element, and smaller set value induces more influence from turbulence light.

*1: Set value changes when the bank is switched.

*4: A white reference object is necessary at the four right-most columns in the screen.
The whole brightness should be adjusted based on this section.

★: Patent is being applied.

Function name LCD display	Setting range (Initial value)	Explanation
LCD Up/Down reverse* LCDVIEW	0, 1 (0)	0 : Normal LCD display 1 : Display is up/down reversed. Make this setting when mounting this device upside down. The display of the external monitor reverses only the image screen.
Area display max. value MAXAREA	0 – 9999 (9999)	Sets the area maximum value. When the upper and lower limits exceed this maximum value at teaching, it is considered that the maximum value is set. Used when unit is converted.
OFF delay time OFF DLY	0 – 5000 (0)	Turns OFF the output signal when the condition is not met for over this set time (ms).
ON delay time ON DLY	0 – 5000 (0)	Turns ON the output signal when the condition is met for over this set time (ms).
One-shot output ONESHOT	0, 1 (0)	When set to "1" output signal is output by one shot during the OFF delay time after the output signal turns ON.
Outside area range *5 OUTSIDE	0 – 3 (0)	0 : Turns ON the output signal within the range between the area upper and lower limits. 1 : Turns ON the output signal outside the range between the area upper and lower limits. 2 : Same as "0." However, the bank switch 1 input becomes the output over the area lower limit value. 3 : Same as "1." However, the bank switch 1 input becomes the output over the area lower limit value.

*5: • The output signal is reversed when OUTSIDE is set to "1" or "3." At this time, when either one of "OFF delay," "ON delay" or "One-shot" is set to a value other than "0," the area hysteresis will become "0."

- The device works with its output signal ON immediately after the teaching or the power ON when OUTSIDE is set to "1" or "3" and none of "OFF delay," "ON delay" and "One-shot" is used.

★: Patent is being applied.

Function name LCD display	Setting range (Initial value)	Explanation
Resolution*6 RESOLUT	0, 1 (1)	Sets the fineness of the pixels taken out of the image sensor. 0 : High resolution mode (240 × 200) 1 : High speed mode (240 × 100); Set to increase the response time, leaving the view range as is.
Synchronous input delay time SYNCDLY	0 – 255 (0)	Sets the delay time of a synchronous input signal. Delays only by the time obtained by multiplying a synchronous input signal by 64 microseconds of the set value. Used to make a fine adjustment of the image-taking timing.
Synchronous input*7 SYNCHRO	0 – 4 (4)	Sets a synchronous input signal. When set to "0" to "3" the bank switch 3 input becomes invalid. Also, the response time becomes constant at the time twice the standard transfer time. 0 : Takes image continually while a synchronous input signal is OFF. 1 : Takes image when a synchronous input signal is switched from ON to OFF. 2 : Takes image continually while a synchronous input signal is ON. 3 : Takes image when a synchronous input signal is switched from OFF to ON. 4 : Invalidates synchronous input signal (Image is always taken.)

*6: Brightness changes when RESOLUT is changed. In such a case, perform teaching again. Note that the output signal may turn ON/OFF momentarily when this set value is changed.

- *7:
- When SYNCHRO is set to "1" or "3" one image taken immediately after the switch is operated is not displayed. However, the judgment output signal is effective. Also, the right-most column in the screen is displayed at the very left. This is only a problem of the screen display, and image is displayed normally when an image is taken.
 - When SYNCHRO is set to "0" or "2" and the bank switch 3 input width (0 is OFF width, 2 is ON width) is less than the response time, an image is displayed on the screen (including present area) once per twice, but the output signal is renewed every time.
 - When SYNCHRO set value is changed, an image may remain on the image screen. The screen is displayed normally when the screen is renewed by taking an image.



Function name LCD display	Setting range (Initial value)	Explanation
Teaching function enable*8 TEACHEN	0 – 3 (0)	<p>0 : Permits the change and movement of the teaching window, and the change of the image-taking range.</p> <p>1 : Prohibits the change of the image-taking range.</p> <p>2 : Fixes the teaching window and the image-taking range.</p> <p>3 : Prohibits teaching.</p>
Teaching mode TEACHMD	0 – 3 (0)	<p>0 : Performs normal teaching. The darkest and brightest colors are detected in the teaching window, and a color within the range is treated as the detection color.</p> <p>1 : Performs the dirt and character detection teaching. Makes a dark color in the teaching window the detection color.</p> <p>2 : Similar to "0." However, teaching is performed with the brightness fixed.</p> <p>3 : Similar to "1." However, teaching is performed with the brightness fixed.</p>
Teaching margin TEACH%	0 – 30 (15)	Sets the color detection range at teaching. The range of the color detection extends when the set value is increased.
Temperature compensation level TEMPCMP	0 – 255 (30)	<p>The temperature compensation level of the image sensor. For instance, adjust by this value if the color taught at low temperature shifts at high temperature.</p> <p>No compensation is performed when set to "0." No compensation works when the color filter (COLRFIL) is set to "1" or "3" and the resolution (RESOLUT) is set to "0."</p>

*8: External teaching can be executed by setting BANK to "16 or less" even when TEACHEN is set to "3."

5 TROUBLESHOOTING

When A Trouble Has Occurred

The following table describes the measures to be taken when this device does not operate properly or cannot detect appropriately.

Item	Ref. page
Color cannot be correctly detected by teaching.	☞ See Page 31.
Image-taking range is narrow, and image is zoomed in.	☞ See Page 32.
Image-taking range cannot be changed by teaching.	
Position of the teaching window cannot be changed.	
Teaching cannot be executed. (No response is made even when  is pressed for 3 sec. or more.)	
Area value shifts after teaching is executed.	☞ See Page 33.
Color cannot be detected when the device is used for a while.	
Other colors are detected when the device is used for a while.	☞ See Page 34.
External teaching cannot be executed.	
External bank input does not work.	
Image of moving work is unstable blurred.	
Area varies depending on the moving speed of work.	☞ See Page 35.
Response time is long.	
Indication area value is small.	
Set value cannot be changed.	☞ See Page 36.
Output is not correctly done.	
Unchanged image remains in the screen.	☞ See Page 37.
Image screen is not renewed.	
Noise image is displayed at the left edge of the image screen.	
Brightness of the screen right after the bank is switched is strange.	
"x" is displayed on the screen regardless of the area that turns ON the output signal.	☞ See Page 38.
"  " is displayed on the screen regardless of the area that turns OFF the output signal.	
Screen display cannot be made brighter.	☞ See Page 39.
How can the image right after the output signal has changed be checked?	
Detection color is not clear. How is it confirmed?	☞ See Page 40.

Q Color cannot be correctly detected by teaching.

- A** TEACHMD (teaching mode) may be set to "1" or "3."
 • Normally, set it to "0."
- A** The teaching window may be too large, protruding beyond the color to be detected.
 • Display **↓SIZE** or **↔SIZE** in the Teaching Setting screen, and reduce the size of the teaching window by pressing .
 ☞ See "1-point Teaching" on Page14.
- A** The set value of TEACH% (teaching color margin) may be too great, enlarging the color selection range.
 • Normally, set it to "10" to "20. "
- A** Lighting may be OFF.
 • Set LIGHT (lighting control) to 1 or add an external lighting.
- A** Is there any white reference object at the right edge of the screen when COLRFIL (color filter) is set to "1"?
 • Place a white object (not shiny object) at the right edge of the screen.
- A** The set value of KIL BLK (darkness correction factor) may be extremely great.
 • When COLRFIL (color filter) is set to "0" or "2" and the value of KILBLK is too great, everything becomes white when black and gray are detected.

C Image-taking range is narrow, and image is zoomed in.

A Return the image-taking range to its original setting by teaching.

- Display **ZOOM** in the Teaching Setting screen, and reset the zoom-in display by pressing .

☞ See "1-point Teaching" on Page 14.

C Image-taking range cannot be changed by teaching.

A TEACHEN (teaching function enable) may be set to "1" or "2."

- Normally set it to "0."

A The teaching window may be too small.

- Display **SIZE** or **SIZE** in the Teaching Setting screen, and increase the size of the teaching window by pressing .

☞ See "1-point Teaching" on Page 14.

C Position of the teaching window cannot be changed.

A TEACHEN (teaching function enable) may be set to "2."

- Normally set it to "0."

C Teaching cannot be executed. (No response is made even when is pressed for 3 seconds or more.)

A TEACHEN (teaching function enable) may be set to "3."



- Normally set it to "0."

C Area value shifts after teaching is executed.

A The upper and lower limit teaching is executed if AREA HI (area lower limit) is set to a value other than "0."

- Normally set it to "0."

A 2-point teaching is executed when  is pressed while teaching is performed.

- Pressing  for 3 seconds or more will enter the set value. Teaching mode is switched to the 2-point teaching if hand is released from [SET] button within 3 seconds. Therefore, confirm whether or not "TCH LOW" is displayed in the screen in case when hand is released from  button within 3 seconds by mistake. "TCH LOW" displayed in the screen shows that the present teaching mode is the 2-point teaching mode. In such a case, press  again to restore the 1-point Teaching mode.

G **Color cannot be detected when the device is used for a while.**

A TEMPCMP (temperature compensation level) may be an improper value.

- Normally set it to "30." When the color shifts, detection becomes successful by adjusting this value. (However, this is effective only when RESOLUT is set to "1" and COLRFIL is set to "0" or "2.")

A The set value of COLOR% (color margin) may be small.

- Making this value greater will widen the color detection range.
- In order to widen the detection range on teaching, increase the set value of TEACH% (teaching color margin).

G **Other colors are detected when the device is used for a while.**

A TEMPCMP (temperature compensation level) may be an improper value.

- Normally set it to "30." When the color shifts, detection becomes successful by adjusting this value. (However, this is effective only when RESOLUT is set to "1" and COLRFIL is set to "0" or "2.")

A The set value of COLOR% (color margin) may be great.

- Making this value smaller will narrow the color detection range.
- In order to narrow the detection range on teaching, decrease the set value of TEACH% (teaching color margin).

G External teaching cannot be executed.

- A** BANK (bank selection) may be set to "17."
• Set it to "0 – 16" to enable external teaching.

G External bank input does not work.

- A** BANK (bank selection) may be set to "0 – 15."
• Set it to "16" or "17" to utilize the external bank input.
- A** SYNCHRO (synchronous input) may be set to "0 – 3."
• Bank switch 3 input becomes a synchronous input when SYNCHRO is set to "0-3." Normally set it to "4."
- A** OUTSIDE (outside area range) may be set to "2" or "3."
• Bank switch 1 input becomes an output signal within the area lower limit range when OUTSIDE is set to "2" or "3." Normally, set it to 0."

G Image of moving work is unstable blurred.

- A** The shutter time may be long since BRIGHT (brightness) is set to a great value.
• Perform teaching again after setting COLRFIL (color filter) to "2" or "3" to increase the sensitivity.
• Perform teaching again after setting TEACHMD (teaching mode) to "2 (normal)" or "3 (teaching for dirty condition) to reduce the set value of BRIGHT (brightness).

G Area varies depending on the moving speed of work.

- A** The shutters open or close in sequence from the right to the left in the screen. Therefore, area becomes greater if the work flows from the right to the left and it becomes smaller if work flows from the left to the right.
• Mount this device so that work flows in the vertical (up and down) direction in the screen. By doing so, the area hardly changes although the imaged work inclines.

Q Response time is long.

A SYNCHRO (synchronous input) may be set to "0 – 3."

- It is necessary to double the response time when SYNCHRO is set to "0 – 3." Set it to "4" when not using any external synchronous signal.

A IRESOLUT (resolution) may be set to "0."

- The horizontal resolution becomes doubled as well as the response time when RESOLUT is set to "0." Normally, set it to "1" if there is no problem.



Q Indication area value is small.

A MAXAREA (area maximum value) may be set to a value less than "9999."

- Normally, set it to "9999." The value set here becomes the area maximum value.



Q Set value cannot be changed.

A The set value may be locked.

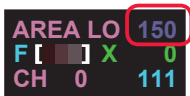
- The set value is locked (change prohibited) when it is indicated in blue. To release the locked condition, display the corresponding set item on the Set Value Reference screen, and press  and  simultaneously for 3 seconds or more.



- All parameters lock

Press  and  simultaneously in the normal screen. Then, the screen is switched to the Set Value Reference screen, and all parameters fall into the locked condition (edition prohibiting condition) in 3 seconds.

- Set TEACHEN (teaching function enable) to "3" to prohibit teaching.



Output is not correctly done.

- A** OUTSIDE (outside area range) may be set to "1" or "3."
 - Output turns ON at the range beyond the area limits when OUTSIDE is set to "1" or "3." Normally, set it to "0."
- A** ONDLY (ON delay) may be set to a great value.
 - If the ON delay time is long, it takes time to turn ON the output signal, and longer OFF condition may be regarded as OFF by mistake. Normally, set it to "0."
- A** ONESHOT (One-shot) may be set to "1."
 - When OFFDLY (OFF delay) is set to a small value and ONESHOT is set to "1," the output signal is output only for a very short time.
 - Normally, set ONESHOT to "0" or set OFFDLY (OFF delay) to a greater value as necessary if one-shot output signal is going to be used by setting ONESHOT to "1."

Unchanged image remains in the screen.

- A** There may be defected pixels with the image sensor.
 - There is no problem for the actual use.
- A** There may be defected pixels with LCD screen.
 - There is no problem for the actual use.
- A** There may be noise elements with the image sensor.
 - Fixed noise pattern of the image sensor tends to appear as the temperature rises. In such a case, lower the ambient temperature.
 - Set COLRFIL (color filter) to "0" or "1" to reduce noise elements.

Q Image screen is not renewed.

A The image right after the switch operation is not displayed when SYNCHRO (synchronous input) is set to "1" or "3." The judgment output signal is normal even though an image is not displayed.

- Set SYNCHRO to "0," "2," or "4" if there is no problem.

Q Noise image is displayed at the left edge of the image screen.

A When SYNCHRO (synchronous input) is set to "1" or "3," the column to be displayed at the very right on the screen is displayed at the left end; the judgment input signal is normal.

- Set SYNCHRO to "0," "2," or "4" if there is no problem.

Q Brightness of the screen right after the bank is switched is inadequate.

A An image displayed right after the bank is switched to the one for the different image-taking zone, and the brightness of the screen differs from that of the original screen.

- Set SYNCHRO (synchronous input) to "0," "2," or "4" if there is no problem.
- Take a dummy image and use it for judgment.

Q "*" is displayed on the screen regardless of the area that turns ON the output signal.

A Actual output may not be ON yet since the set value of ONDLY (ON delay) is great.

- Wait until the ON delay time.

A One-shot output signal may be complete since ONESHOT (one-shot) is set to "1."

- Change the OFF conditions to the ON conditions again, and confirm that the output signal turns ON.
- Increase the set value of OFFDLY (OFF delay) to lengthen the ON time.

A OUTSIDE (outside area range) may be set to "1" or "3."

- Confirm that the output signal turns ON when the OFF conditions are established.

A Display may be delayed since the ON time is too short.

- The display updating cycle of LCD is approximately 33 ms. The ON status shorter than the updating cycle may not be displayed on the screen.

G "0" is displayed on the screen regardless of the area that turns OFF the output signal.

A Actual output may not be OFF yet since the set value of OFFDLY (OFF delay) is great.

- Wait until the OFF delay time.

A OUTSIDE (outside area range) may be set to "1" or "3."

- Confirm that the output signal turns OFF when the ON conditions are established.
When the set value of HYSTRSY (area hysteresis) is great, the output signal turns OFF only when the area value is rather small.
- Confirm that the output signal turns OFF by creating a condition in which the present area becomes "0."
- Reduce the set value of HYSTRSY.



G Screen display cannot be made brighter.

A The shutter time does not become longer over the horizontal width of the screen if the image-taking range is narrowed by teaching.

- Set RESOLUT (resolution) to "0" to double the horizontal resolution.
- Set COLRFIL (color filter) to "2" or "3."
- In order to widen the horizontal width, mount this device turned by 90 degree so that the width in the vertical (up and down) direction is narrowed.

Q How can the image right after the output signal has changed be checked?

A Utilize the image holding function of this device.

- ① Press  for 3 seconds or more in the normal screen.
- ② The image will be held when the output signal changes.
- ③ By pressing , the image will be held again when the output signal changes for the next time.

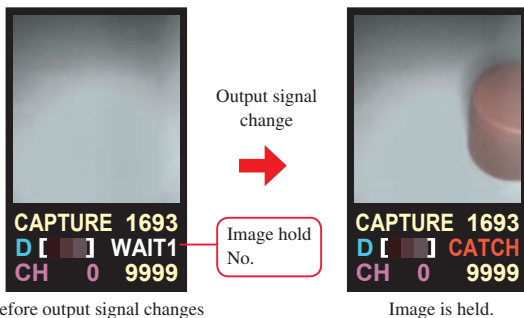

- Note that the device operates normally although the indicated bank number does not change while the image holding function works.
- The normal screen is restored by pressing .

Detection color is not clear. How is it confirmed?

A The display condition of the screen can be switched, focused on the detection color or displaying only the detection color.

F: Normal screen

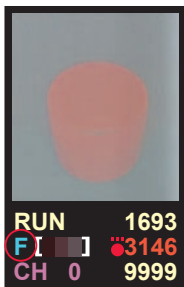

Displays the screen after the color filter is processed.

D: Image screen

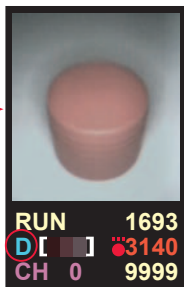

Displays the image taken by the built-in camera as is.

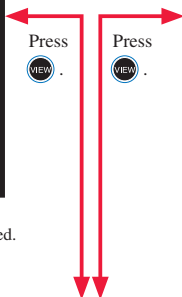

2: Screen to display the detection color only

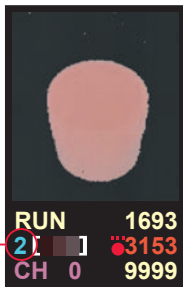

Indicates the display conditions of the present screen.

- Normally, colors other than the detection color are displayed in black.
- When the detection color is dark, colors other than the detection color are displayed in white.



Use "2: Screen to display the detection color only" when the area value after teaching is different from the expected value.

Technique When Teaching cannot be Done Correctly

The following describes the measures to be taken when teaching cannot be done correctly due to a problem in the installation conditions or of the work to be detected.

C Brightness changes since lighting changes according to the orientation.

A Bring the brightness of the darkened color closer to the original brightness.

- Make the set value of KILBLK (darkness correction factor) greater.



When the edge of the screen has darkened

Make the set value of KILBLK greater.



Dark portion becomes brighter, making the whole screen brighter evenly.

Perform teaching after changing the set value.

The set value of KIL BLK is also switched when the bank is switched.

When the set value of KIL BLK is made smaller, the display receives greater influence from turbulence light and the temperature change.

Normally, set it to a value within "10-31."

G The device malfunctions due to the lighting from the setting sun and the factory's indoor lighting.

A Make the set value of COLOR% (color margin) greater when adjusting after teaching.

- ① Confirm that no malfunction occurs by making the set value greater when a work exists.
- ② Confirm that no malfunction occurs when there is no work (or defective work exists).

A Make the set value of TEACH% (teaching margin) greater when adjusting before teaching.

- The color margin at teaching becomes greater. When the set value of COLOR% adjusted after teaching is set to the set value of TEACH%, COLOR% need not be adjusted at every teaching. Also, the present COLOR% value does not change even when TEACH% is revised.

A Install a shield plate to prevent the turbulence light if malfunction still occurs even after ACOLOR% (color margin) and TEACH% (teaching margin) are changed.

G Flaw and smear cannot be correctly detected.

A Flaw and smear cannot be detected correctly if they are detected in a wider range since irregularity occurs in brightness because of the surface roughness.

- Change to the following setting when the background is white.

COLRFIL (color filter) = 1

TEACHMD (teaching mode) = 1

KIL BLK (darkness correction factor) = 27

- Color correction malfunctions when COLRFIL (color filter) is set to "1" when the background is shiny. In such a case, change to the following setting.

COLRFIL (color filter) = 0

KIL BLK (darkness correction factor) = 10 or so

However, note that the device becomes likely to receive the influence of the turbulence light.

- Perform teaching after setting the image-taking range to the one where both the background and flaw and smear can be detected.



Image-taking range

Work flow direction



- ① Press **TEACH** for 3 seconds or more in the normal screen, and switch to the Teaching Setting screen.
- ② Display **SIZE** by pressing **TEACH** and press **UP** to change the teaching window to a rectangular shape.



- ③ Display **ZOOM** by pressing **TEACH** and press **UP** to zoom in only to the teaching window section.

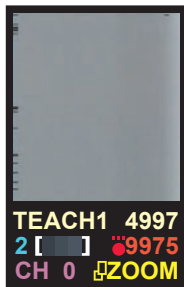

- ④ Press **SET** on a non-defective work to complete the teaching for the 1st point.

- ⑤ Press **SET** for 3 seconds or more on a defective work with flaw and smear to complete the teaching for the 2nd point.
- ☞ See "TEACHING WORK" on Page 13 for the details of teaching.



C The print distinction cannot be done correctly.

A Change to the following setting.

- AREA HI (area upper limit) = 1 (Upper and lower limit teaching; output signal does not turn ON when there is no work.)
- COLRFIL (color filter) = 1 (Brightness is adjusted by the luminance at the right edge of the screen.)
Set COLRFIL (color filter) to "0" and KIL BLK (darkness correction factor) to "10" when a white work does not stably enter to the right edge of the screen.
(This is to weaken the darkness correction level to make the difference between the background and the print clear.)
- TEACHMD (teaching mode) = 1 (dirt teaching)
- RESOLUT (resolution) = 0 (High resolution: thin characters can be distinguished.)

A Perform teaching, taking caution on the following points.

- Make only the printing area to the image-taking range.
- Use a work with prints on it for the 1st point (area upper limit). Select a work with the largest print area.
- Select a work without any prints for the 2nd point (area lower limit).

6 APPENDIX

Specifications

Model	CVS1-N10 CVS1-P10	CVS1-N20 CVS1-P20	CVS1-N40 CVS1-P40
View angle	10°	20°	40°
Object distance	210 – 270mm	90 – 150mm	50 – 100mm
Image-taking range*1	40×50mm – 55×65mm	40×50mm – 65×75mm	50×65mm – 100×115mm
Light source	White LED: 12 pcs		
Power voltage	12 – 24 V DC.±10%		
Current	Max. 220 mA / 12 V DC., 120 mA / 24 V DC.		
Resolution	8×16×3 (RGB) – 200×240×3 (RGB)		
Temperature drift	±2% of RGB each factor (0-40°C)*2		
Lighting durability	Approx. 50000 hours*3		
Lighting luminance tolerance	-70% – +100%*4		
Response speed	0.6 – 22 ms		
Output*5	NPN/PNP O/C, Max. 100 mA, Residual voltage: 10V or less		
Input	Bank switch input: 4 points (1 point is switched to the upper and lower limit terminal.)		
Ambient working temperature	0 – 40°C		
Ambient humidity range	35 – 85%/RH		
Material	ABS / acrylic fiber / polycarbonate		
Protection degree	IP67		
Weight	Approx. 180g		

*1 Tolerance: ±10%

*2 When the set value of KIL BLK is "10" or more

*3 When luminance has dropped to 50% under the normal temperature and humidity circumstance

*4 Representative value when KIL BLK is set to "27"

*5 CVS1-N □□ : NPN I/O, CVS1-P □□ : PNP I/O; □□ shows the view angle (10°, 20°, 40°).

Dimensions Drawing

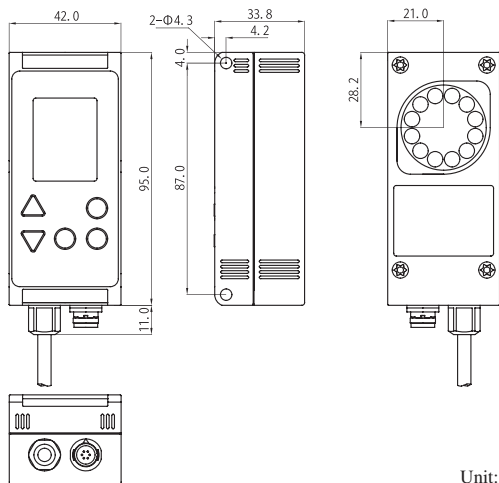

Operation Check By Using A Sample

Three kinds of samples are available. Teach this illustration and use it for the confirmation of set values, etc.

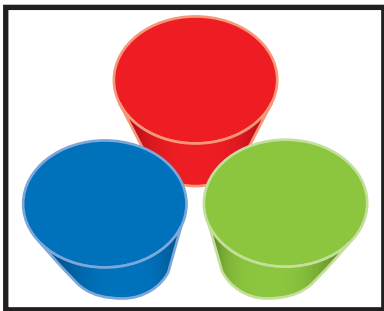

Index

- 1-point teaching 14
- 2-point teaching 18
- All parameters lock 35
- Area display max. value 27
- Area hysteresis 26
- Area lower limit 11, 25
- Area upper limit 11, 25
- Bank number 11
- Bank selection 25
- Cable connector 6
- Color filter 26
- Color margin 25
- Darkness correction factor 26
- Dead pixels 8
- Detection color 11
- Detection color area 11
- DOWN button 12
- Extension cable 9
- External bank input 34
- External lighting 9
- External teaching 9, 34
- Flaw and smear detection 42
- Image holding function 39
- Image screen 11
- Input constant 26
- LCD screen 6, 10
- LCD Up/Down reverse 27
- Lighting 9, 41
- Locked 35
- Mode display 11
- Mounting 7
- Mounting hole 6
- Moving speed of work 34
- Normal screen 10, 11
- OFF delay time 27
- One-shot output 27
- ON delay time 27
- Operating buttons 6, 12
- Options 9
- Output condition 11
- Outside area range 27
- Power / signal cable connector 6, 9
- Print distinction 44
- Remote monitor 9
- Resolution 28
- Response time 11, 35
- Screen brightness 25
- Screen display status 11, 40
- SET button 12
- Set items 25
- Set value change method 23
- Set Value Change screen 10, 11
- Set value lock 35
- Set Value Reference screen 10, 11
- Synchronous input 9, 28
- Synchronous input delay time 28
- Teaching 14, 41
- Teaching function enable 29
- Teaching margin 29
- Teaching mode 29
- Teaching window 14, 32
- TEACH button 12
- Temperature compensation level 29
- Upper / lower limit teaching 20
- UP button 12
- VIEW button 12

Warranty

Period of Warranty

The period of warranty of this device shall be one year after its delivery to the customer.

Range of Warranty

The manufacturer will exchange this device (by sending a substitute), free of charge, on the responsibility of the manufacturer if the failure arises due to the manufacturer's liability during this period of warranty.

However, the failure occurred by the following causes shall be excluded from the manufacturer's warranty.

1. Failure caused by any abuse, misuse, and misapplication
2. Failure due to a cause other than the delivered manufacturer's product
3. Failure caused by an approved modification or repair
4. Failure due to acts of God

The warranty stated herein shall cover only the delivered manufacturer's sole product. The damages that have caused by the failure of the delivered manufacturer's product shall not covered by this warranty.

First edition in August, 2003 of issue
Date issued: August, 2003 First edition

© The contents in this manual are copyrighted and all rights are reserved by the manufacturer. The descriptions and information included in this manual shall not be copied nor reproduced to any other form.

Notice

The models, specifications, etc. included in this manual may be altered without prior notice.

OPTEX CO., LTD.

Headquarters: 46-1 Takehanadounomae-machi, Yamashina-ku,
Postal code: 607-8085 JAPAN

OPTEX FA HOME PAGE: <http://www.optex-fa.com>

0640060