

Linear-Transducer LA41 - A

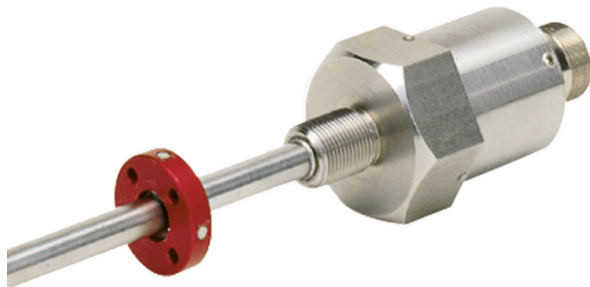

Ref.: K-LA41-A-1

18.11.2013

0102010030

Advantages

- Adjustment via set-inputs
- Customer-specific solutions
- Further interfaces available
- Housing length: 66 mm
- Measures linear movements
- Perfect fit for cylinders
- Pressure proof tube housing
- Wear-free detection

General Data

Supply	
- Supply voltage	24 VDC \pm 10 %
Current consumption no load	\leq 350 mA
Measuring principle	magnetostrictive
Measuring length, standard	150...3000 mm, in steps
Resolution	0.1 mm
Linearity deviation	$<$ 0.05 %
Reproducibility	0.01 mm
Hysteresis	0.1 mm
Temperature coefficient	$<$ 40 ppm/ $^{\circ}$ C
Straight line velocity	no restrictions
Mounting position	no restrictions
Material - Measuring body	Cr/Ni - alloy
Rod end mounting	Option
Magnet	T4-M33
	other on request
Analog - Interface	
- Voltage/Current	Factory setting
- Resolution	12 Bit D/A converter
- Voltage output	-10...+10 VDC
- Load resistance (U)	\geq 0.68 kOhm

Subject to change.

TR-Electronic GmbH
 Eglisshalde 6
 78647 Trossingen
 Tel. +49 (0) 7425 228-0
 info@tr-electronic.de
www.tr-electronic.de

Linear-Transducer LA41 - A

Ref.: K-LA41-A-1

18.11.2013

0102010030

General Data continuation

- Current output	0...20 mA
- Load resistance (l)	≤ 500 Ohm
Cycle time, internal	see dimensional drawing
External inputs	
- Set-Input 1	Analog initial point
- Set-Input 2	Analog end point
- Logic level	"0" < +2V, "1" = Supply

Environmental conditions

Vibration	
- Specific value	≤ 100 m/s ²
- Sine	50...2000 Hz
Shock	
- Specific value	≤ 1000 m/s ²
- Half sine	11 ms
Immunity to disturbance	DIN EN 61000-6-2
Transient emissions	DIN EN 61000-6-3
Working temperature	
- Standard	0...+70 °C
- Optional	-20...+70 °C;
Storage temperature, dry	-30...+85 °C
Relative humidity	98 %, non condensing
Protection class	
- Standard	IP65
Stray magnetic field	< 3 mT
Measuring reference	Measuring plane
Pressure resistance	
- Optional	600 bar, static

Subject to change.

Linear-Transducer LA41 - A

Ref.: K-LA41-A-1
 18.11.2013
 0102010030

Dimensional drawing

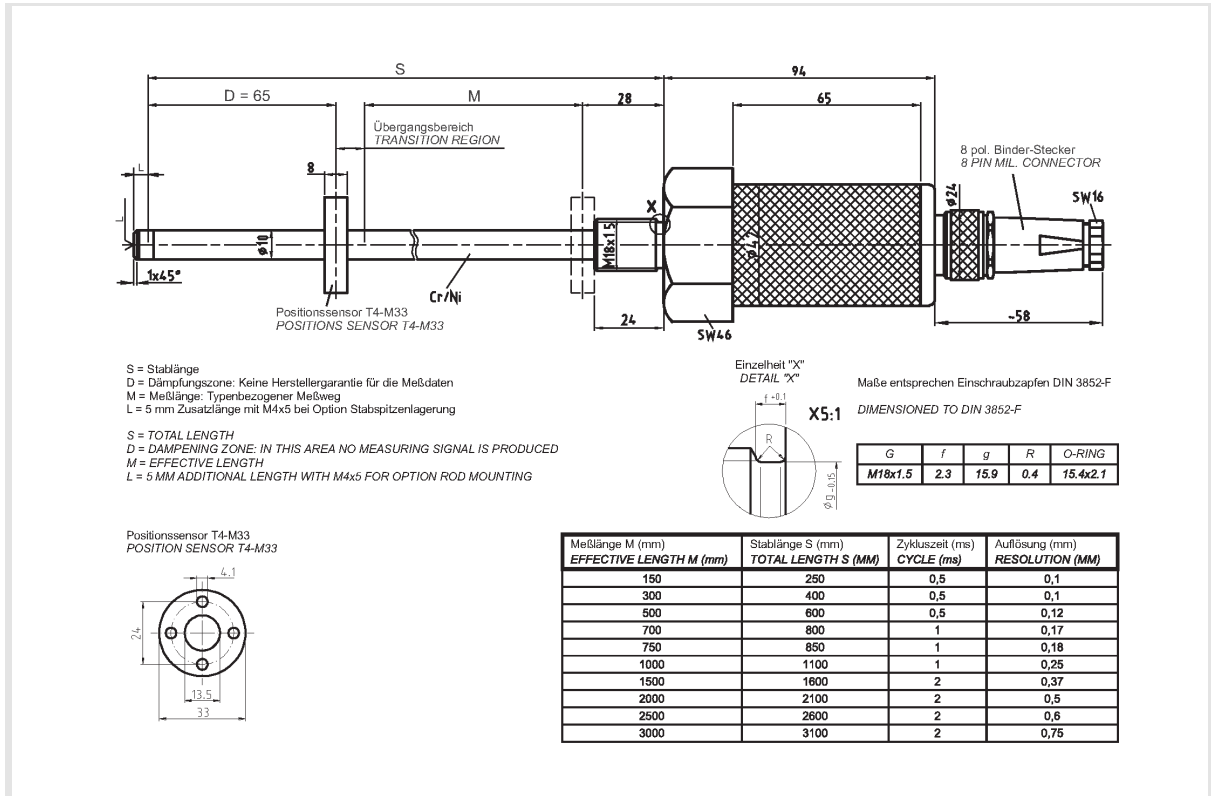

Subject to change.

TR-Electronic GmbH
 Eglshalde 6
 78647 Trossingen
 Tel. +49 (0) 7425 228-0
 info@tr-electronic.de
www.tr-electronic.de