

# 3D LIDAR YVT-35LX Specification

**CE**  
**RoHS**

△×								
△×								
Symbol	Amended reason				Pages	Date	Amended by	No
Approved by	Checked by	Drawn by	Designed by		3D LIDAR YVT-35LX Specification			
<i>M.Hono</i>	K.Kimoto	H.Takegawa	H.Takegawa	Drawing No	C-42-04283			1/11

## 1. Introduction

### Operation principle

- This sensor uses laser beam ( $\lambda=905\text{nm}$ ) to scan a semispherical field. User can obtain the distance and its corresponding angle data. The distance of an object is measured by using the Time of Flight (TOF) principle. User can convert the measurement data into 3D coordinate by using transform calculation.
- This product is class 1 laser product.

## 2. Structure (Scanning image of laser beam)

### (1) Structure diagram

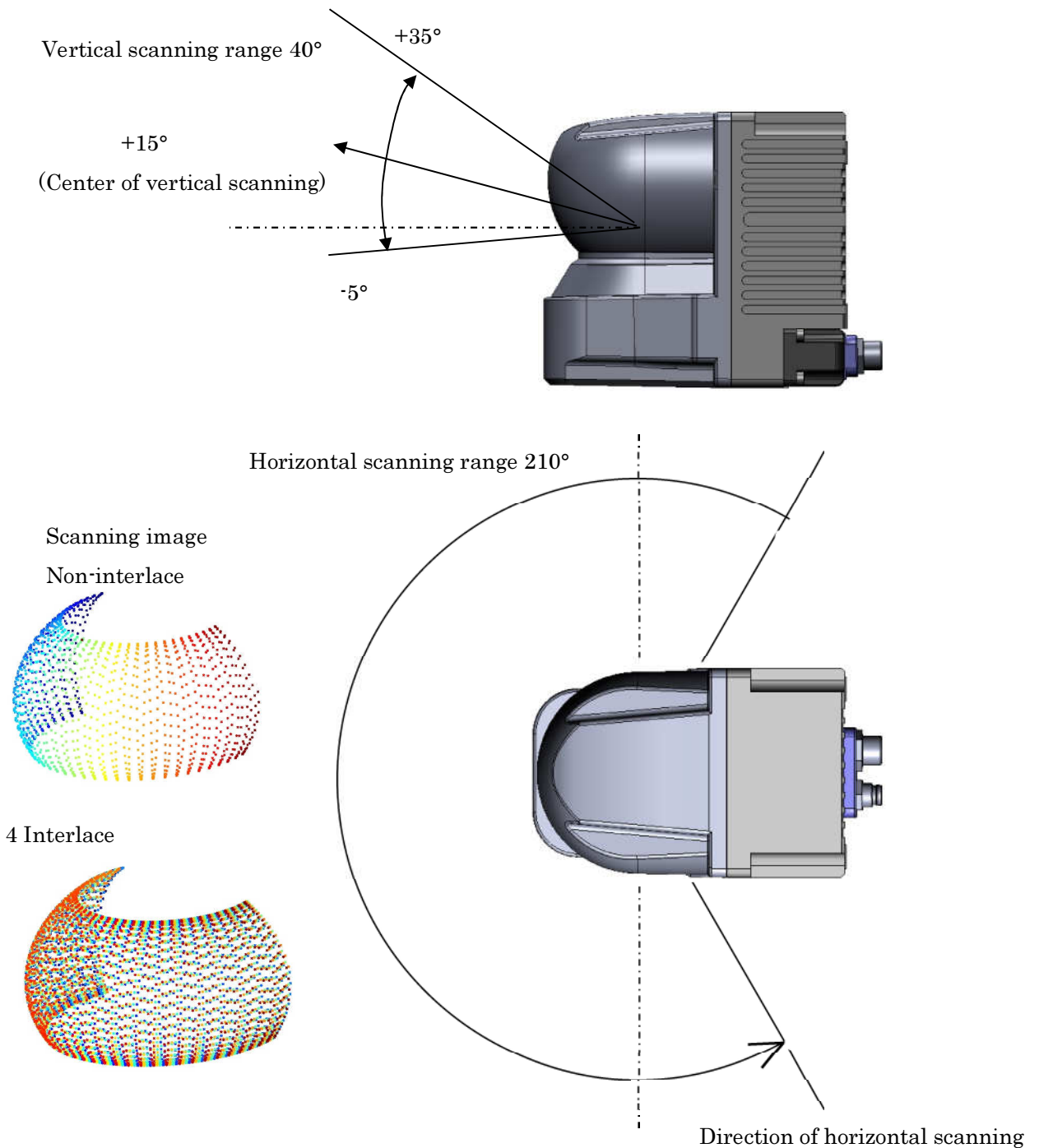

Title

3D LIDAR YVT-35LX Specification

Drawing No

C - 42 - 04283

2 / 11

(2) Explanation of laser beam

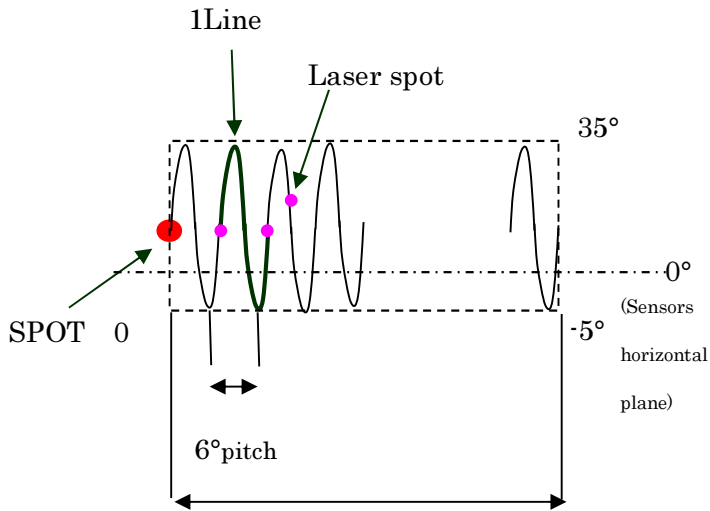

1Frame	Max 200Field
1Field	36Line
1Line	74spot (Total90spot - OFF 16spot)
Laser off spot17,19,20,21,23,24,25,27, 63,65,66,67,69,70,71,73	

Caution: SPOT NO.0 is line starting point 0 °

(3) Mutual relation between field, line and spot (During non-interlace)

Coordinate transform diagram

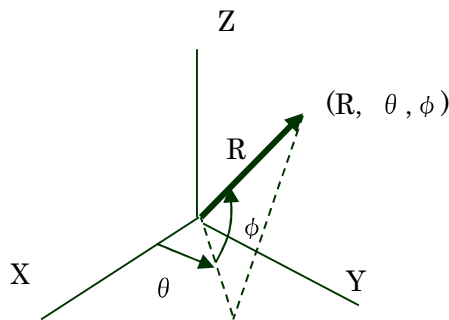

$\theta$  : Rotating direction of the motor while performing horizontal scan

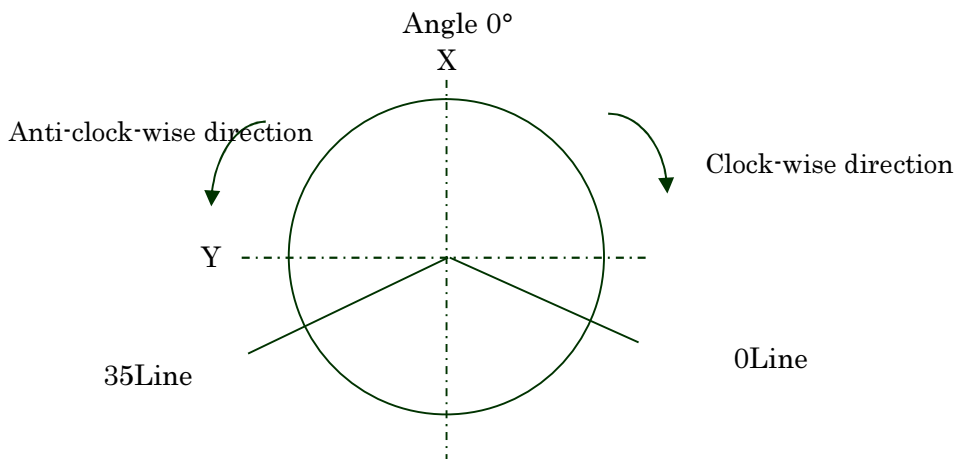

Title	3D LIDAR YVT-35LX Specification	Drawing No	C - 42 - 04283	3 / 11
-------	---------------------------------	------------	----------------	--------

### 3. Specification

Product name	3D LIDAR
Model	YVT-35LX
Light source	Laser diode Wave length=905nm Laser Safety Class 1(IEC60825-1:2007 and IEC60825-1:2014)
Supply voltage	DC12V / 24V (Operating Voltage Range 10~30V) (When using DC12V : Startup 1.5A / Normal 0.8A)
Horizontal scan angle	210° or more pitch 6° Accuracy $\pm 0.125^\circ$
Vertical scan angle	40° (-5° to 35°) Accuracy $\pm 2^\circ$
Data spots (Resolution)	2590 spots or more (No interlace, 20fps) 518000 spots or more (Interlace HD mode, 0.1fps)
Interlace	Horizontal: Max 20 times HD Mode: Horizontal 20 times $\times$ vertical 10 times
Detection range at center of vertical scan (upward 15°)	Horizontal scan $-45^\circ < \theta < 45^\circ$ 0.3-35m (white paper) 0.3-11m (black paper reflectance 10%) $-75^\circ < \theta \leq -45^\circ$ , $45^\circ \leq \theta < 75^\circ$ 0.3-20m(white paper) 0.3- 6m (black paper reflectance 10%) $\theta \leq -75^\circ$ , $75^\circ \leq \theta$ 0.3-10m(white paper) 0.3-3m (black paper reflectance 10%) * Detection range at vertical scan upward 35° / downward -5° is 70% at center of vertical scan (upward 15°)
Detection accuracy (at temperature 25°C)	Center White paper below 15m: $\pm 50\text{mm}$ White paper 15m~ : $\pm 100\text{mm}$
Repeated accuracy (at temperature 25°C)	Center White paper below 15m: $\sigma < 20\text{mm}$ White paper 15m~ : $\sigma < 35\text{mm}$
No. of detection echo	UP to 4 echoes
Horizontal scan speed	20Hz
Vertical scan speed	1200Hz
Input / Output	PPS Input : photo-coupler input (Active high at 2mA or more) Synchronous Output : photo coupler open collector output (30VDC 50mA MAX)
Interface	Ethernet (TCP/IP) 100BASE-TX (Auto-negotiation)
Protective structure	IP67 (Power supply is off) Not waterproof
Weight	Approx. 650g
Size	70mm $\times$ 106mm $\times$ 95mm (W $\times$ D $\times$ H)
Ambient temperature, humidity	-10 to 50°C below 85% (Without dew/frost)
Vibration	10 to 57.5Hz double amplitude 1.5mmp-p 57.5Hz to 150Hz 98m / s <sup>2</sup> (10 G) for 2hrs in each X,Y and Z direction Sweep rate: 1 octave/min (3.9sec / sweep) (Both in operating and non-operating state)
Noise level	In front direction 59db (at distance 250mm) Frequency 1200Hz
Surrounding intensity	100,000lx (Avoid direct sunlight)

Title

3D LIDAR YVT-35LX Specification

Drawing No

C - 42 - 04283

4 / 11

Gyro	Acceleration and angular velocity (InvenSense MPU-6500) #1
Communication protocol	VSSP 2.1
EMC	(EMI)EN61326-1:2013 EN55011:2009+A1:2010  (EMS)EN61326-1:2013 EN61000-4-2:2009 EN61000-4-3:2006+A1:2008+A2:2010 EN61000-4-4:2012 EN61000-4-6:2009 EN61000-4-8:2010

\*1 For details refer to Gyro's catalogue.

Caution: Sensor's warm up duration is about 60 sec after power ON. During the warm up state measurement data cannot be obtained. Also, it requires about 2 to 3 min for stable vertical scan.

Caution: Refer to the inspection sheet for detail on accuracy data of the device. During product shipment, test is performed only at front direction. Detection distance and accuracy may differ depending on the direction of measurement. Also, above mentioned accuracy during temperature 25° C.

Caution: Near range data may contain noise in the first echo of upper direction spots.

Caution: Objects with very low reflectivity may not be detected at the near range even when it is detected at the different range.

Title	3D LIDAR YVT-35LX Specification	Drawing No	C - 42 - 04283	5 / 11
-------	---------------------------------	------------	----------------	--------

\*Image of detection distance range

Horizontal scanning

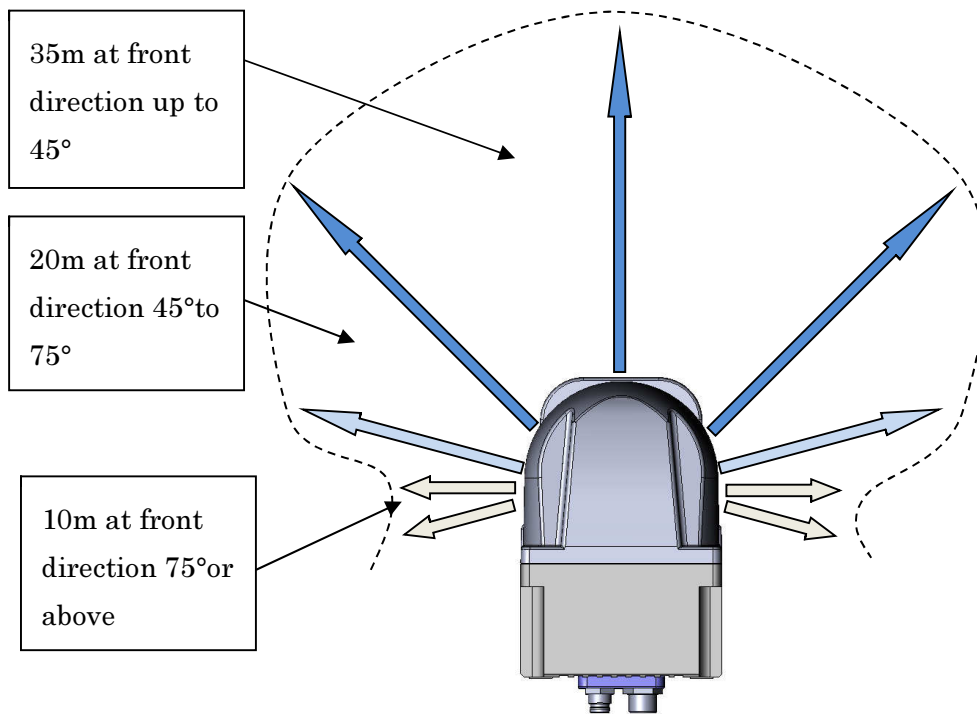

Vertical scanning

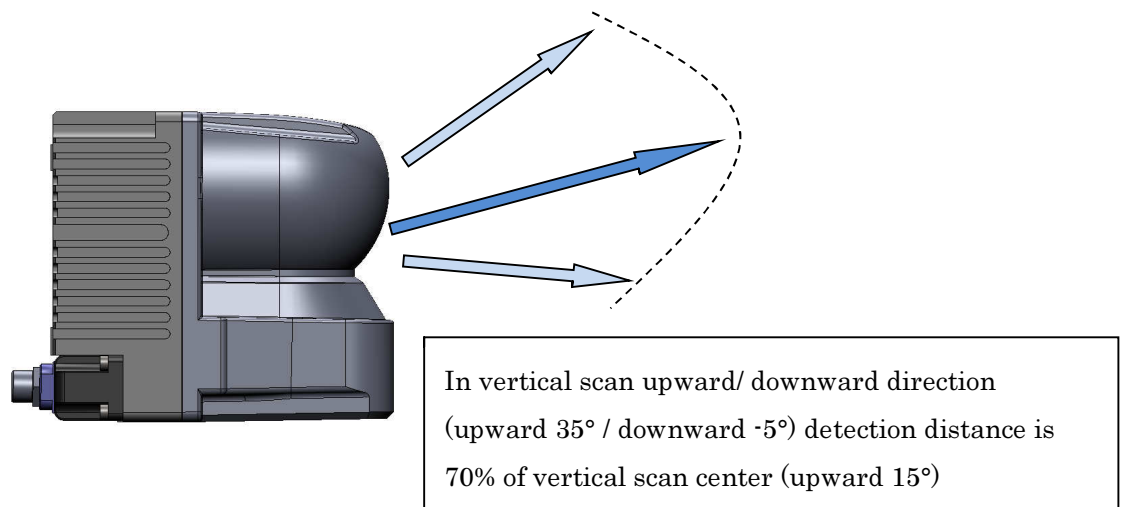

Title	3D LIDAR YVT-35LX Specification	Drawing No	C - 42 - 04283	6 / 11
-------	---------------------------------	------------	----------------	--------

#### 4. Gyro data

The example of data obtained from InvenSense MPU-6500 is as below

##### FS setting

Angular\_vel : Each velocity 500deg/s full scale 16bit

Accel\_ : Acceleration ±4G full scale 16bit

Caution: XYZ coordinate of sensor and InvenSense MPU-6500 will be different.

Mutual relation of coordinates

Sensor	Angular_vel/Accel_
X	Z
Y	X
Z	Y

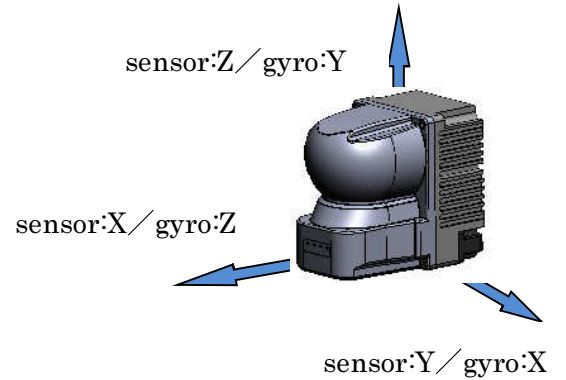

Caution: The function of magnet \_X/Y/Z does not operate normally, therefore it cannot be used.

For the details on other data, refer to the catalog of InvenSense MPU-6500.

angular_vel_X	-67		
angular_vel_Y	216		
angular_vel_Z	-261		
accel_X	-128		
accel_Y	8368		
accel_Z	-2492		
magnet_X			
magnet_Y			
magnet_Z			
temperature	11216		

## 5. Connection and indicator lamp

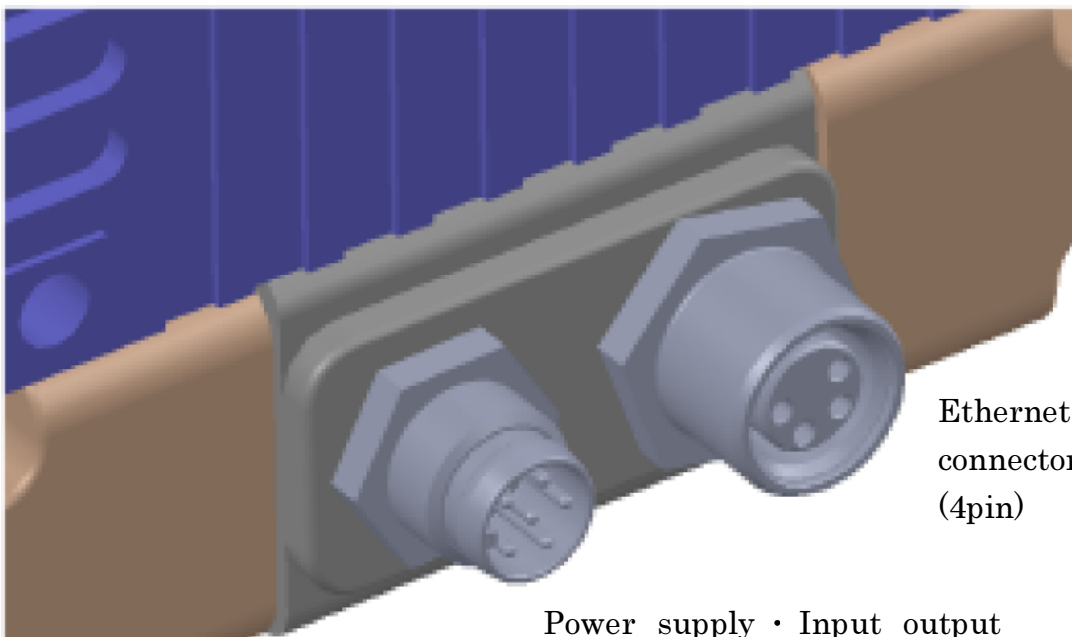

Ethernet  
connector  
(4pin)

Power supply · Input output  
signal connector (6pin)

### 5-1.Connector pin

#### 5-1-1Power supply input/output connector

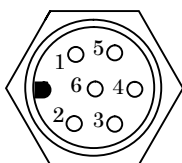

binder product M8 waterproof connector  
Model No.:09 3463 00 06

PIN No	Function
1	+VIN (DC12 / 24V)
2	PPS COM
3	-VIN (0V)
4	-COM
5	SYNC OUT
6	PPS IN

#### 5-1-2 Ethernet connector

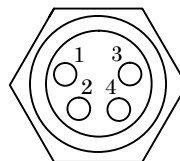

binder product M8 waterproof connector  
Model No.:09 3420 00 04

PIN No.	Function
1	TX+
2	RD+
3	RD-
4	TX-



### 5-1-3 Input/output circuit diagram

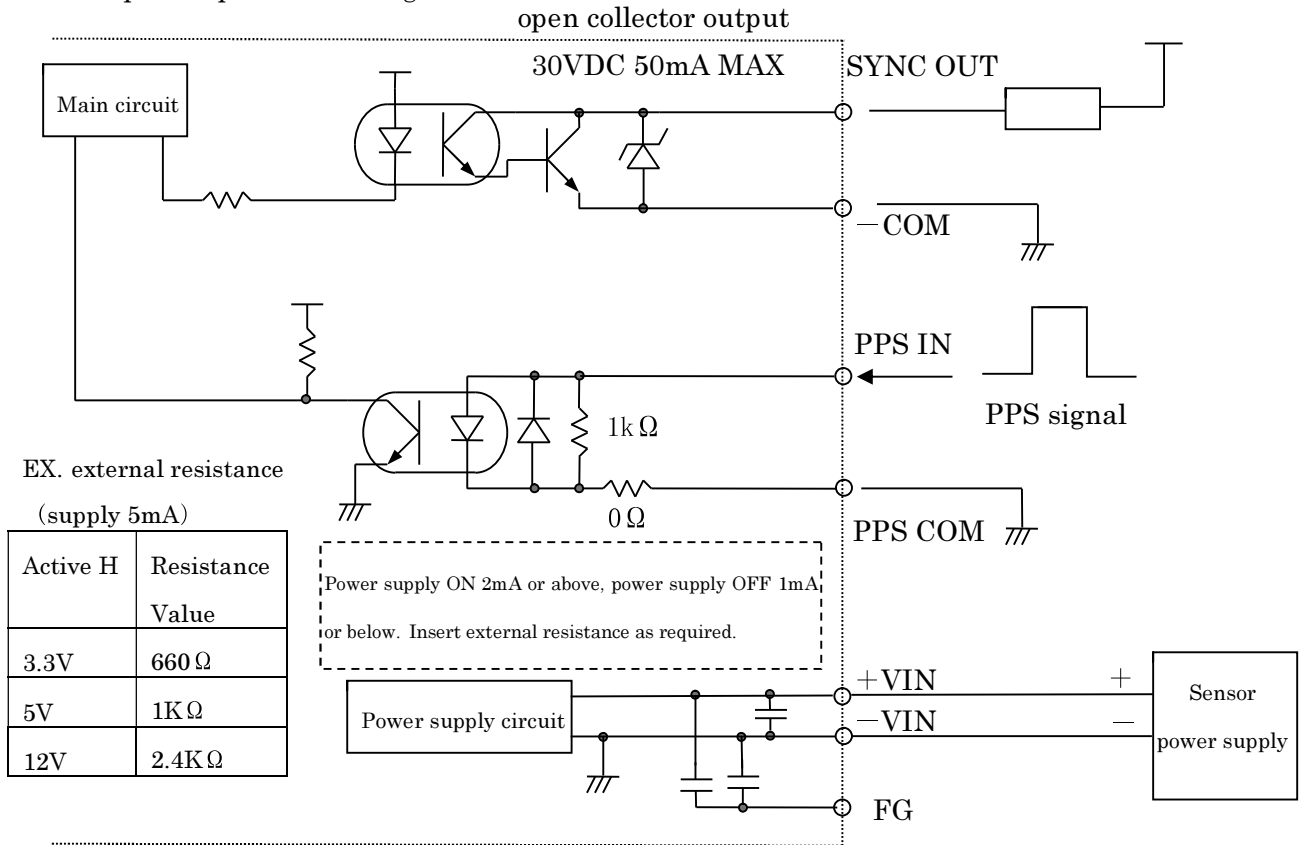

### 5-1-4 Synchronous output

Sensor outputs a 1ms pulse in every scan which is synchronous with the scanning. The timing of the synchronous output signal is shown in the figure below.

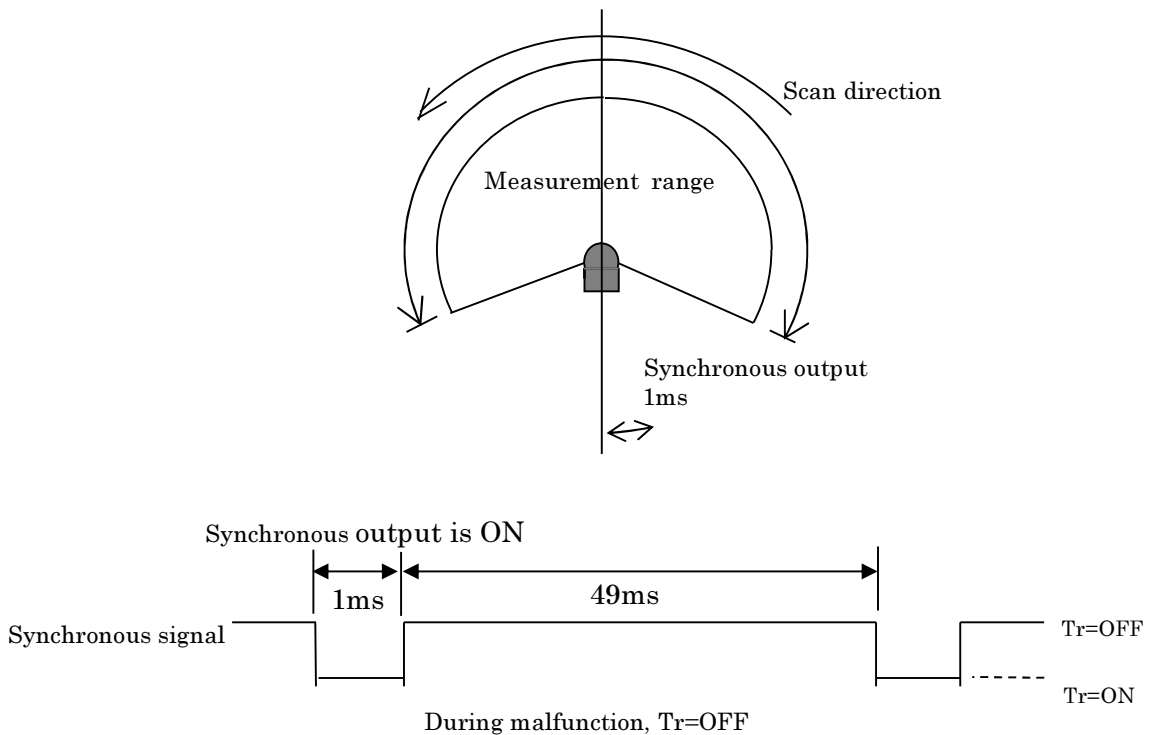

## 5-2 Connection cable specifications (Sold separately)

### 5-2-1 Power supply cable

Model No.: YVT-C003 (3m) / C005 (5m)

PIN No.	Function	Wire color
1	+VIN (DC12 / 24V)	Brown
2	PPS COM	White
3	-VIN (0V)	Blue
4	-COM	Black
5	SYNC OUT	Gray
6	PPS IN	Pink

### 5-2-2 Ethernet cable

Model No.: YVT-ENET003 (3m) / ENET005 (5m)

M8 Waterproof connector		
PIN No.	Function	Wire color
1	TX+	Yellow
2	RD+	White
3	RD-	Blue
4	TX-	Orange

RJ45		
PIN No.	Function	Wire color
1	TX+	Yellow
2	TX-	Orange
3	RD+	White
4	NC	—
5	NC	—
6	RD-	Blue
7	NC	—
8	NC	—

For more details on the communication protocol, refer to the communication specification.

## 5.3 Indicator lamp



Power supply	Green
Malfunction	Red
Communication	Orange

## 6. Ethernet setting

### 6.1 Initial value

Initial value of IP : 192.168.0.10

Port number : 10940

Title	3D LIDAR YVT-35LX Specification	Drawing No	C - 42 - 04283	10 / 11
-------	---------------------------------	------------	----------------	---------

## 7. Cautions

Heat is generated as the sensor runs at a very high speed.

The heat generated is concentrated at the back side of the sensor. Please mount heatsinks or any appropriate component to release the generated heat.

An aluminum plate (200 x 200 x 2) is recommended as the heatsinks.

## 8. Disclaimer

- This sensor is not certified for the functional safety.
- This sensor cannot be used for human body detection as per the machinery directives.
- Sensor emits laser for measurement. Sensor's operation may become unstable under the influence of strong interference light or when emitted lights are not reflected back from the object.
- Sensor's operation may become unstable due to rain, snow and fog or due to dust pollution on the optical window.
- Rules and regulations related to safety should be strictly followed when operating the sensor.
- When there is a risk that this sensor is intended for use in mass-destruction weapons, weapons and equipment aimed at killing human beings, and relevant technologies, or when uses for such purposes are clear, sales may be prohibited in accordance with the Foreign Exchange and Foreign Trade Act, and the Export Trade Control Order (Japanese law). Moreover, regarding export of products, the formalities according to laws/Export Trade Control Order are implemented in order to maintain international peace and safety.
- Caution – Use of controls or adjustments or performance of procedures other than those Specified here in may result in hazardous radiation exposure.
- Before using the sensor, make sure to read this specification thoroughly.

Title	3D LIDAR YVT-35LX Specification	Drawing No	C - 42 - 04283	11 / 11
-------	---------------------------------	------------	----------------	---------