



Micro Detectors

Italian Sensors Technology



Application:
water level detection
in whirlpool baths

CQ50, CQ55
Capacitive Sensors



Proximity Sensors

Application note

CAT3E001262601

Application note - cubic capacitives models - English - Ed.01/2012



MARKET SECTORS

DESCRIPTION OF THE MARKET SECTOR AND ITS TYPICAL ACTIVITY

APPLIED SOLUTION

TECHNICAL FEATURES & SPECIFICATIONS

Pools

Vending machines distributing hot beverages like milk, coffee or tea, need to detect the level of powders that have to be mixed with hot water.

M.D. Micro Detectors' Capacitive Sensors can detect the level granting the correct distribution of products.

		CQ50	CQ55
dimensions		7 x 30 x 50 mm	15 x 35 x 55 mm
standard shielded		—	—
standard unshielded		—	—
long distance shielded		5/6/7/10 mm	4...25 mm
long distance unshielded		—	—
standard housing		●	●
short housing		—	—
miniaturized housing		—	—
supply voltage	Vdc	●	●
	Vac	—	—
output type	NPN - NO	●	—
	NPN - NC	●	—
	PNP - NO	●	—
	PNP - NC	—	—
	PNP - NO + NC	—	●
	NPN - NO + NC	—	●
	DECOU* [®]	—	—
	SCR	—	—
	0...10 V	—	—
4...20 mA	—	—	
temperature range		-0°C...+60°C	-25°C...+80°C
protection degree		IP67	IP67
housing material		Noryl	PC
active head material		Noryl	PC
output	cable	●	●
	M8 plug	—	—
	M12 plug	—	●
other certifications		CE	UL LISTED CE

CQ50

- DC supply voltage
- High noise immunity
- Adjustable sensitivity

CQ55

- Capacitive water level sensor

DIMENSIONS

CQ50/**-A (cable exit)

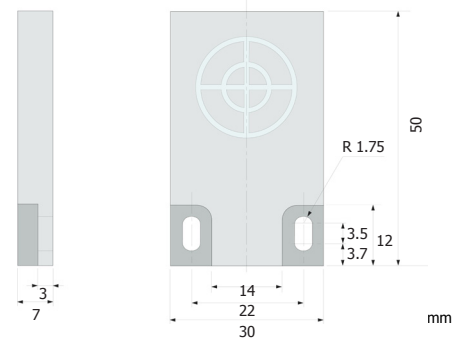

CQ55/**-3A (uscita a cavo)

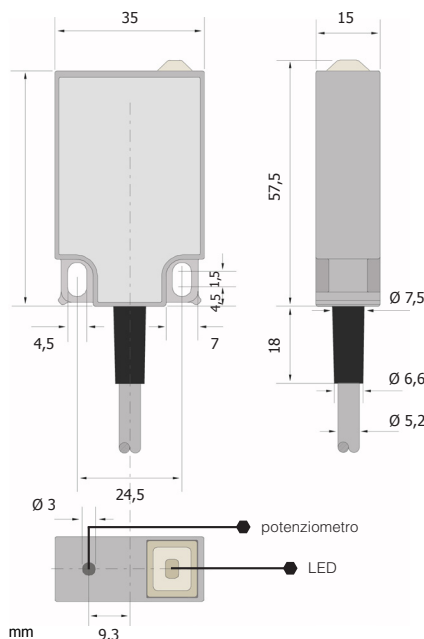

CQ55/**-3E (uscita a connettore)

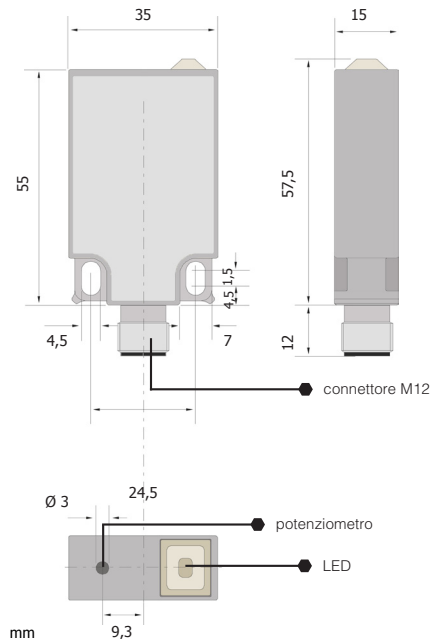

Copyright:

M.D. Micro Detectors S.p.A.
con Unico Socio

Strada S. Caterina 235
41122 Modena - Italy

tel. + 39 059 420411
fax + 39 059 253973
info@microdetectors.com
www.microdetectors.com

