



# INDUCTIVE PROXIMITY SENSORS

PORTFOLIO EXCERPT

# WELCOME TO DI-SORIC



- **100% owner-managed**
- **Headquarters**  
Urbach, Germany
- **Technology and production center**  
Lüdenscheid, Germany
- **Representatives and branch offices**  
in more than 40 countries
- **Certifications**  
IQNet, DQS - ISO 9001:2015, UL, RoHS

For over 40 years, di-soric GmbH & Co. KG has been developing, producing, and selling sensors featuring a wide variety of technologies. These sensors are used in industrial automation – primarily in assembly and handling technology, in the automotive, electronics and pharmaceutical industries and in packaging technology. Other important cornerstones of our product range are innovative vision sensors and code readers, high-quality LED lighting for machines and image processing, and products from the segment of safety technology.

Our own ambition is to benefit you. When we develop products and solutions to handle your tasks, we always strive to make them both as simple and as practical as possible.

We draw upon our high level of technical know-how and a clear view of the developments of tomorrow to support our customers – today and in the future – with precise, non-disruptive and efficient production processes.



## OUR PROMISE TO YOU:

### **Solutions.**

**To us, finding solutions means:**

- Targeted consultation and technical expertise for efficient product solutions
- A very broad, high-performance product range

### **Clever.**

**To us, being clever means:**

- Developing products with clear benefits
- Products that are easy to use thanks to clever functions
- Joint dialog for the most efficient and most suitable solution

### **Practical.**

**To us, being practical means:**

- Solution expertise with the best possible functionality at affordable prices
- Cooperative and straightforward working relationships for mutual success
- Focus on the key issues for greater efficiency

# INDUCTIVE PROXIMITY SENSORS

## Contact-free and safe detection of metallic parts.









Inductive proximity sensors play an important role in industrial automation and are used in the millions in many different industries and applications.



di-soric offers the right solutions for many industry-specific and individual automation requirements - from standard to the most demanding high-end applications.

Our inductive proximity sensors are available in Ø 3 mm to M30 models as well as cubic designs.

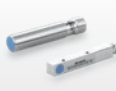
Fully metallic versions, pressure-resistant sensors up to 500 bar, as well as up to 3x or 4x switching distances supplement our product range, in addition to sensors with an analog output. We are continually making developments to our portfolio to offer our customers real added value in a digitized industrial environment.

<b>EXCERPT FROM OUR SERIES</b>		Switching distance	Description	Page
	<b>INS Standard</b>	<b>Sn x1 Sn x2</b>	The optimal solution for industrial applications with standard switching distances and typical installation and application conditions	4
	<b>INSM Standard Mini</b>	<b>Sn x1 Sn x2</b>	An efficient solution for industrial applications with limited installation space	5
	<b>INE Extended</b>	<b>Sn x2 Sn x3</b>	Inductive sensors with extended switching distances, various housing lengths and diverse connection variants for demanding installation and application conditions	6
	<b>INC Advanced</b>	<b>Sn x4</b>	Sensors with the longest range – for all industrial areas in which a secure solution is needed for detecting distant objects or detecting objects with very high reduction factors	7
	<b>INW Fully metallic robust</b>	<b>Sn x2 Sn x3</b>	Extremely robust, fully metallic models for solutions with increased risk of mechanical contact with the object to be detected or with small metallic parts in a tooling machine	8
	<b>INP High-pressure resistant</b>	<b>Sn x1</b>	The high-pressure resistant, fully metallic models are a good solution for detecting objects under high pressure, e.g. in hydraulic systems	9
	<b>INA Analog</b>	<b>Sn x3</b>	Models with an analog output are the solution for applications in which distances to metal objects are measured	10
	<b>Accessories</b>		Customized accessories for sensors	11

# INS STANDARD

## Switching distance Sn x1 and Sn x2 in standard designs – flush, non-flush, cable and plug variants.

The proximity sensors in the INS series are distinguished by a sufficient functional reserve and offer you the optimal “cost-benefit ratio” for standard industrial applications. INS sensors have proven themselves in various industries, e.g. in assembly and handling technology, the machine tool industry, in packaging machines and many others. These sensors have single and double switching distances and can be connected with plugs or PVC cables.



### Advantages of the INS standard series:

- The optimal solutions for industrial applications with standard switching distances and application conditions in typical installation situations
- Sizes and models: Standard thread sizes M8-M30, and Q8 rectangular - this way you will always find the right sensors for you standard applications
- The sensors with the high protection class IP67 are dust-proof and protected against strong water jets. The resulting durability under industrial conditions reduces time and resources spent for maintenance and repair.
- The sensor can be integrated easily and quickly into the control system with the connection variants plug or PVC cable. The flexible PVC cable, in particular, which is easy to adapt to the required length, has proven itself in the integration and replacement of the sensors.

CE IP67

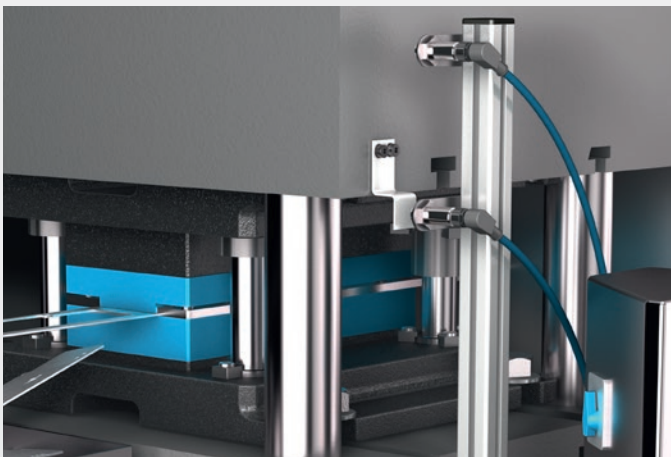

### Detecting the position of a press

INS M30

The precise position of a press platform needs to be detected during operating cycles. For this application, INS standard sensors in horizontal and vertical orientation are used in order to safely and precisely detect the end positions of the press platform.

### AVAILABLE MODELS AT A GLANCE:

Sizes	Switching distance	Housing length	Material	Functions	Connection	Protection class
M8 - M30 Q8, Q30, Q40	Sn x1 Sn x2	Normal	Stainless steel Brass	NO/NC	PVC cable Connector	IP67

# INSM

## STANDARD MINIATURE

**Ø 3 to 6.5 mm thread / cylinder, 5 x 5 mm cubic  
in normal model length – switching distance Sn x1 and Sn x2**

The INSM Standard Miniature series is an efficient solution for industrial applications with a small installation diameter or limited installation space. They are available with thread and cylinder sizes from 3 mm to 6.5 mm and square dimensions of 5 x 5 mm in normal housing lengths and are distinguished by a sufficient functional reserve. These sensors can be connected by way of a plug or PVC cable.



### Advantages of the INS Standard Miniature series:

- The optimal solutions for industrial applications with limited installation space
- Small diameters from D3 to D6.5 and Q5 rectangular - this way you will always find the right sensors for compact installations
- The sensors with the high protection class IP67 are dust-proof and protected against strong water jets.
- The sensor can be integrated easily and quickly into the control system with the connection variants plug or PVC cable. The flexible PVC cable, in particular, which is easy to adapt to the required length, has proven itself in the integration and replacement of the sensors.

CE IP67

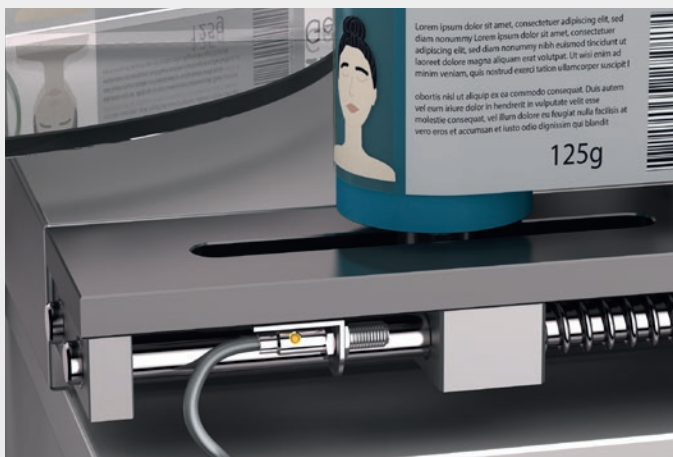

### Detect end position of a pulley

INSM M5

For high-quality sticker labels it is very important that the label holder strip is properly tensioned. An inductive sensor monitors the position of the pull roll in the packaging machine. The signal from this sensor is used to control the feed of the holder strip. This guarantees the proper tension of the sticker strip and thus the exact position of the label during adhesion.

### AVAILABLE MODELS AT A GLANCE:

Sizes	Switching distance	Housing length	Material	Functions	Connection	Protection class
D3 - D6.5 Q5	Sn x1 Sn x2	Normal	Stainless steel Brass	NO/NC	PVC cable Connector	IP67

# INE EXTENDED

## Switching distance Sn x2 and Sn x3 in normal and short models – flush, non-flush, cable, plug, and pigtail variants.

The INE Extended series is used in many industries for demanding applications where there are additional requirements for the design or the connection options. For this reason, the INE Extended series includes sensors with a double and triple switching distance, in normal and short models, and various connection variants such as PVC or PUR cable, integrated or pigtail plug connections.



CE IP67

### Advantages of the INE Extended series:

- Double and triple switching distance – safe solutions for demanding industrial applications
- Normal and short models - always an optimal solution even under tight installation conditions
- All sizes and models from square to small diameter to standard M8-M30 are available - always the right sensor for nearly any application
- The sensors in the INE Extended series have the high protection class IP67, they are dust-proof and protected against strong water jets. The resulting durability under industrial conditions reduces time and resources spent for maintenance and repair.
- The models with PUR cable also have an increased resistance to cutting oils.

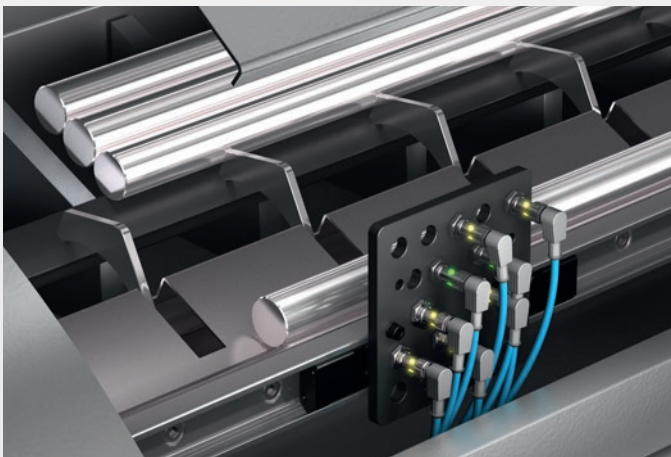

### Position detection for feeding carriages for various rod lengths

INE M12 short model

INE sensors are installed on a metallic plate and detect whether the tool revolver block has reached the correct index position after a belt movement. They not only detect the tightening bar, but also the locking mechanism. Due to the limited installation space, this application requires sensors in short model lengths.

### AVAILABLE MODELS AT A GLANCE:

Sizes	Switching distance	Housing length	Material	Functions	Connection	Protection class
D3 - D6.5 M8 - M30 Q5 - Q40	Sn x2 Sn x3	Normal Short	Stainless steel Brass	NO/NC	PVC cable PUR cable Connector Pigtail	IP67

# INC ADVANCED

## Switching distance and Sn x4 in normal models – flush, non-flush, cable, plug, and pigtail variants.

The sensors in our INC Advanced series guarantee precise, process-reliable object detection at a maximum of 4x distance.

With these sensors, switching distances of 8 mm (with M12 flush design) up to 40 mm (with M30, flush design) can be implemented for ambitious applications.



### Advantages of the INC Advanced series:

- 4X switching distance – for all areas of industry, in which a safe solution for detection of distant objects is required or safe detection of objects with very high reduction factors is to be guaranteed.
- The technical features of the sensors meet the high protection class IP67. The models with PUR cable also have an increased resistance to cutting oils.
- The various connection options enable easy connection of the sensors to the control system.

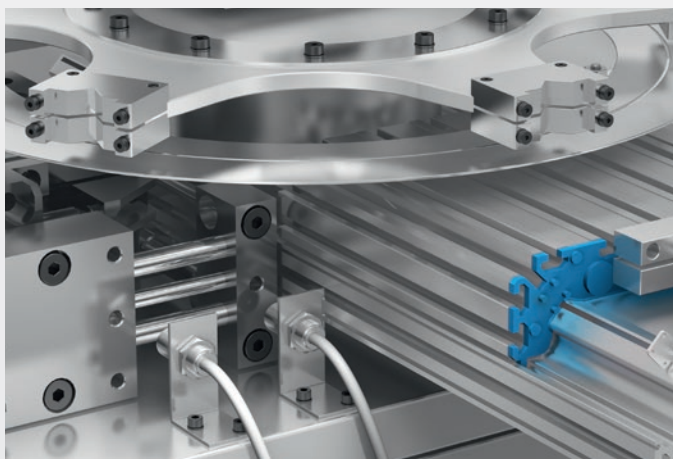

### Detection of end position

#### INC M12

The INC sensor detects the end position of the actuator within the assembly machine. The installation of the sensor requires a greater distance from the actuator, and it must simultaneously be ensured that the position of the actuator is precisely detected. Thanks to a scanning range that is four times longer, it is possible for the INC sensor to meet both requirements and thus perform its task.

### AVAILABLE MODELS AT A GLANCE:

Sizes	Switching distance	Housing length	Material	Functions	Connection	Protection class
D6.5 M8 - M30	Sn x4	Normal	Stainless steel Brass	NO/NC	PVC cable Connector Pigtail	IP67

# INW

## FULL METAL EXTENDED

### Switching distance Sn x2 and Sn x3 in normal models – flush, non-flush, cable and plug variants.

These sensors are robust fully metallic sensors for challenging applications. They are a secure choice for solutions that pose increased risk of mechanical contact with the detected objects and metallic parts. INW sensors have single and double switching distances and can be connected with PUR cables or plugs.



CE c  us IP68/IP69K

#### Advantages of the INW Extended series:

- The extremely robust fully metallic models are designed for applications in which there is an increased risk of mechanical contact with the object to be detected or there may be contact in the tool machine with metal chips.
- Models with a double and triple switching distance allow, depending on the area of application, safe operation of the sensors in tooling machines.
- Thanks to its stainless steel housing, they satisfy the requirements of the highest protection class IP69K. The models with PUR cable also have an increased resistance to cooling and cutting oils.
- Factor 1 models with equivalent switching distances for iron and aluminum

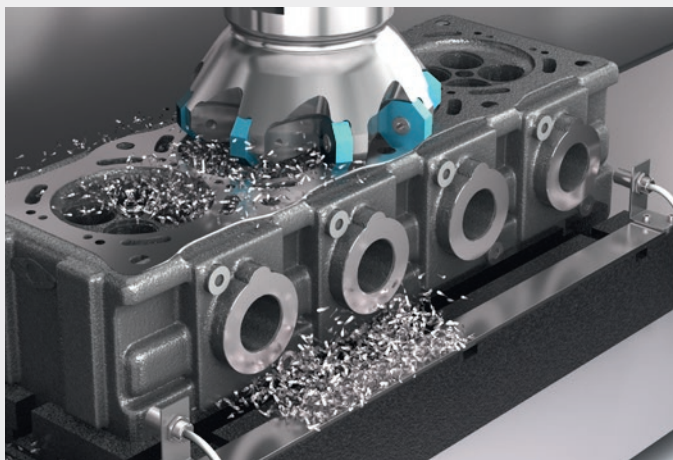

#### Position detection of processing parts

INW M18

The INW sensor detects the precise position of the components to be processed in the processing space of lathes and milling machines.

Whether or not the sensor is subject to constant contact with cooling and cutting oils in this situation, the INW sensor is able to safely detect the end position of the workpiece under the working tool.

#### AVAILABLE MODELS AT A GLANCE:

Sizes	Switching distance	Housing length	Material	Functions	Connection	Protection class
D3 - D6.5 M8 - M30	Sn x2 Sn x3	Normal	Stainless steel	NO/NC	PUR cable Connector	IP68 / IP69K



# INP

## HIGH-PRESSURE RESISTANT

### Switching distance and Sn x1 in normal models – flush, non-flush, cable and plug variants.

Our high-pressure resistant INP sensors can handle the pressure. They withstand a process pressure up to 500 bar and are available with a stainless steel housing in sizes M12, M14 and M18. They are optimal and safe for position monitoring in hydraulic systems or monitoring of valve positions under high pressure.



#### Advantages of the INP High-Pressure Resistant series:

- The high-pressure resistant, fully metallic models are a good solution for detecting objects under high pressure, e.g. in hydraulic systems.
- The INP series satisfies the requirements of the highest protection class IP69k. The models with PUR cable also have an increased resistance to cutting oils.
- Models with special PTFE cable are suited for chemically aggressive environments.

CE IP68/IP69K

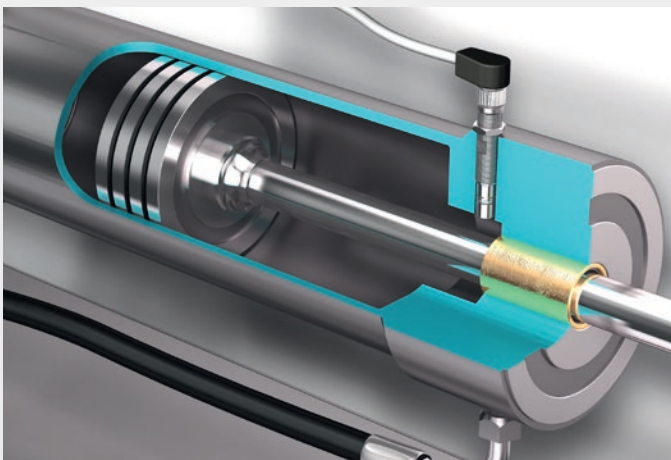

#### Position detection under high pressure

INP M12

In hydraulic systems, the speed of an actuator is adjusted by regulating the throughput rate. Here the throughput rate determines the position of the cylinder that is actuated within the system.

Inductive INP sensors can detect the end position of the drive within the hydraulic cylinder under high pressure.

#### AVAILABLE MODELS AT A GLANCE:

Sizes	Switching distance	Housing length	Material	Functions	Connection	Protection class
M12, M14, M18	Sn x1	Normal	Stainless steel	NO/NC	PUR cable PFTE cable Connector	IP68 / IP69K

# INA ANALOG

## Switching distance and Sn x3 in normal models – flush, non-flush, cable and plug variants.

The INA Analog series includes highly precise inductive proximity sensors which have an analog current and voltage output available.

They are suited for measuring changes in distances of metallic parts in production or testing processes in which small changes in distance can reflect the quality of the process.

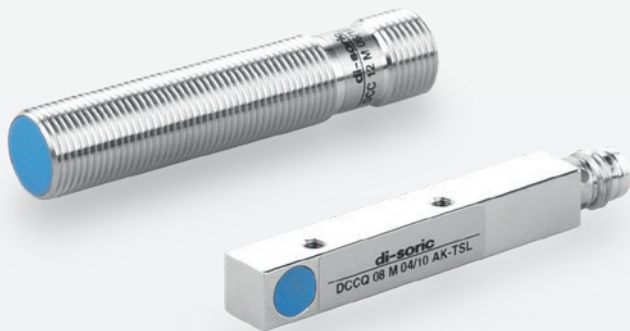

### Advantages of the INA Analog series:

- Special models with an analog output are the solution for applications in which distances to metal objects are measured.
- Applications with large distances can be implemented in a process-reliable manner due to the triple switching distance.
- The sensors in the INA series correspond to the high protection class IP67. The models with PUR cable also have an increased resistance to cutting oils.

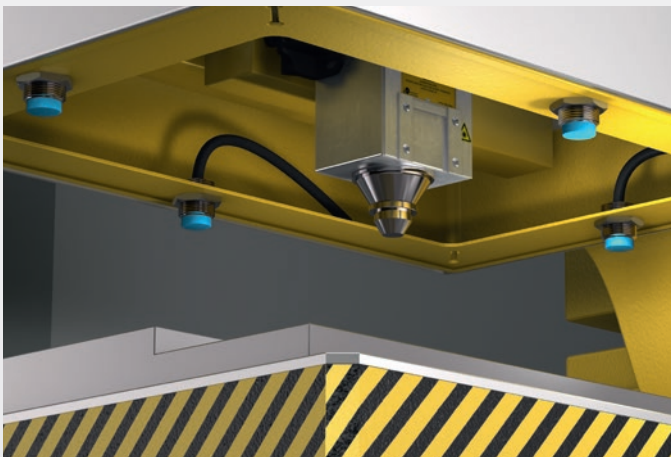

### Measuring the distance of a marker to the workpiece

#### INA M30

INA sensors measure the distance to the workpiece and on the basis of this regulate the position of the marker in the tooling machine.

Here the thickness of the workpiece is detected by the sensor and, for the correct positioning of the marker, is passed on to the external control system via the output signal.

### AVAILABLE MODELS AT A GLANCE:

Sizes	Switching distance	Housing length	Material	Functions	Connection	Protection class
M8 - M30 Q8	Sn x3	Normal	Brass	0 - 10 V 0 - 5 V 1 - 5 mA 4 - 20 mA	PVC cable PUR cable Connector	IP67

# ACCESSORIES FOR SENSORS.

## Customized accessories for proximity sensors.

It is not only the quality of the sensors that plays a major role in the process-reliable detection of parts and objects. The accessories are also very important. They can ensure flexible, stable mounting, secure signal transmission and much more.

The complete set of accessories can be found at [www.di-soric.com](http://www.di-soric.com)



For example: SH sensor holders for sensors with a diameter from 3 mm to 30 mm.

## Connection technology

In the area of connection technology, a wide variety of electrical contacts for custom industrial-suited assembly are available.

## Logic distributors - Function adapters

di-soric offers logic distributors and function adapters for nearly all requirements. Logic distributors can logically connect several sensors together and output the desired behavior accordingly, for example an AND/OR function. Function adapters can change sensor-specific functions to the desired function (e.g. pulse stretching).



**SOLUTIONS. CLEVER. PRACTICAL.**

### **di-soric Headquarters**

**Germany:** di-soric GmbH & Co. KG | Steinbeisstrasse 6 | 73660 Urbach  
Phone +49 71 81 98 79-0 | Fax +49 71 81 98 79-179 | [info@di-soric.com](mailto:info@di-soric.com)

### **di-soric Subsidiaries**

**France:** di-soric SAS | Phone +33 4 76 61 65 90 | [info.fr@di-soric.com](mailto:info.fr@di-soric.com)

**Netherlands:** di-soric B.V. | Phone +31 413 33 13 91 | [info.nl@di-soric.com](mailto:info.nl@di-soric.com)

**Austria:** di-soric Austria GmbH & Co. KG | Phone +43 7228 72 366 | [info.at@di-soric.com](mailto:info.at@di-soric.com)

**Switzerland:** di-soric B.V. | Phone +41 44 817 29 22 | [info.nl@di-soric.com](mailto:info.nl@di-soric.com)

**Singapore:** di-soric Pte. Ltd. | Phone +65 6634 38436 | [info.sg@di-soric.com](mailto:info.sg@di-soric.com)

Further information: [www.di-soric.com/international](http://www.di-soric.com/international)

**[www.di-soric.com](http://www.di-soric.com)**