

Vision Sensor



Cost Effective Vision Sensors and LED lighting for machine vision

VISION SENSOR LINE UP

Multi Camera Vision Sensor MVS Series

MVS-PM Color pattern matching camera unit



Direction of electronic parts

It can detect color and shape of target object.

Application examples :

- Inspection of electronic parts
- Inspection of position of parts for automobile
- Checking existence of some material by its color

MVS-EM Measurement camera unit



Positioning of printed circuit board

It can measure distance between edges on the objects.

Application examples :

- Measuring diameter of parts for automobile
- Counting edges on the surface of parts
- Measuring pitch of lead frame for electronic parts

MVS-OCR Color OCR camera unit



Shelf life of confection

It can inspect Date, Time and Text.

Application examples :

- Inspection of shelf life on the label
- Inspection of lot number on the label
- Inspection of type mark on the parts for automobile

MVS-DN-E Controller

Controller has Touchscreen for easy operation.



The controller supports up to 3 cameras

You can connect 3 different cameras to controller



All in one Vision Sensor CVS Series

Lens, Image sensor, LED lighting, LCD display and vision processor are in one body.

All in one structur



CVS1easy-R, CVS1-R

Color area Detection



Checking existence of printing on the box

CVS2-R

Shape/Color area Detection



Checking multiple colors on the box

CVS3-R

Edge detection



Checking overlapping of the label

CVS4-R

OCR



Checking shelf life on the packaging film

MVS SERIES APPLICATION

MVS Series

CVS Series

MVS Series APPLICATION

MVS-PM/EM

MVS-OCR

OPTIONS

1. Detecting presence of metal washer

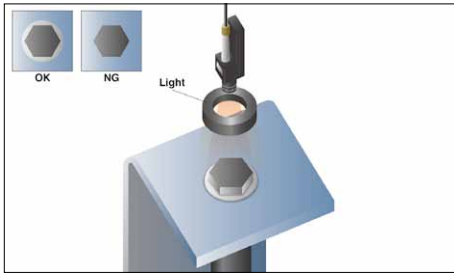

MVS-PM
-Detect its area by color

MVS-EM
-Measure the diameter of the washer

2. Checking engine spark plugs

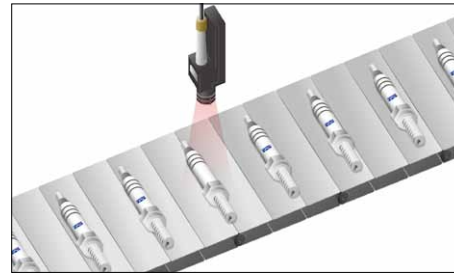

MVS-PM
-Contour matching

MVS-EM
-Measure its character

MVS-OCR
-Check the part number

3. Checking amount of paint or glue applied

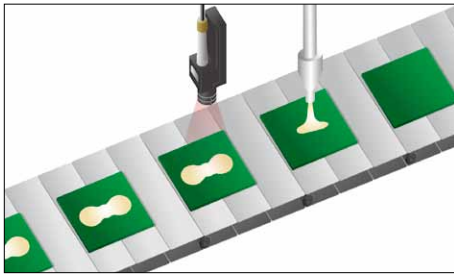

MVS-PM
-Check its area by color

MVS-EM
-Measure its size in X/Y

4. Checking engine position

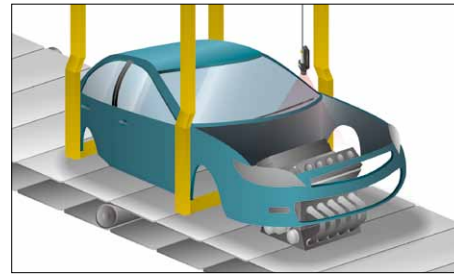

MVS-PM
-Check position by pattern matching

MVS-EM
-Measure the distance of body - engine

5. Check bead of sealing rubber for continuity

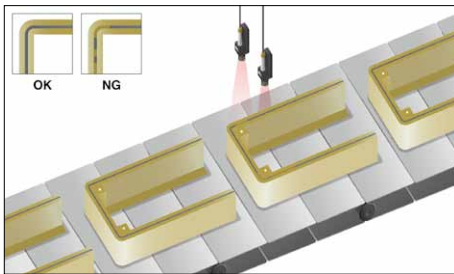

MVS-PM
-Check color area of the rubber

6. Checking display of vehicle speed panel

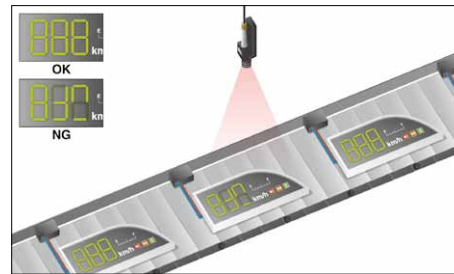

MVS-PM
-Check color area in each part
-It can check up to 16 parts utilizing 16 inspection windows

7. Checking shape of O ring



MVS-PM
-Check shape by contour

MVS-EM
-Measure the diameter

8. Checking gap between doors

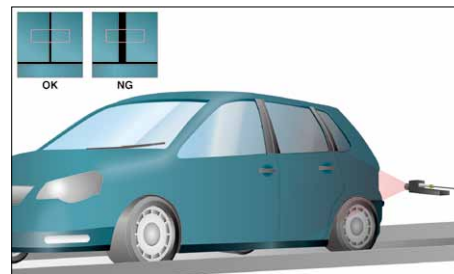

MVS-PM
-Check area of the gap

MVS-EM
-Measure the gap

9. Verifying fuse position and type in fuse panel

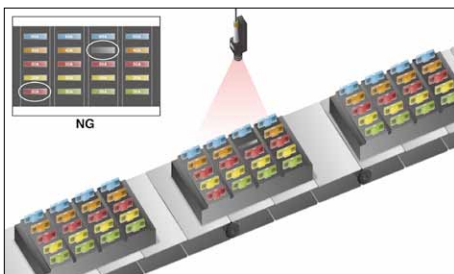

MVS-PM
-Check color of fuse and position
-Lighting to be mounted from side to reduce surface reflection

10. Checking shape of piston valve

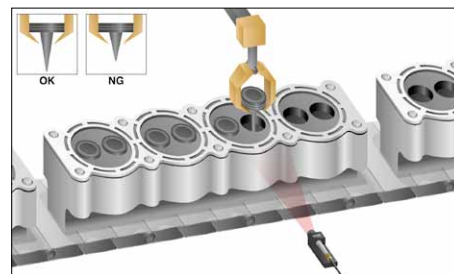

MVS-PM
-Check the shape by pattern matching

MVS-EM
-Measure the dimensions

11. Check flame to ensure the presence of material

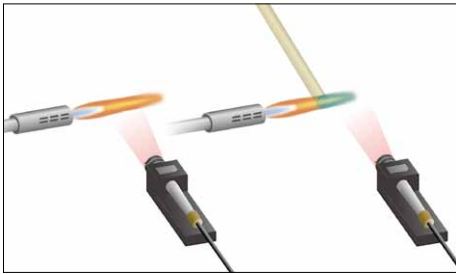

MVS-PM
-Check color
area of flame

12. Check LED color and parts position

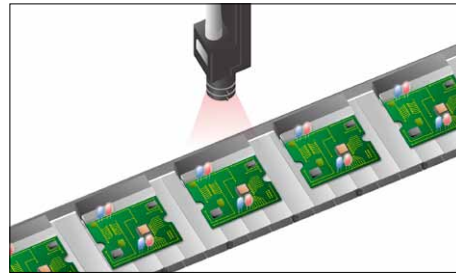

MVS-PM
-Check parts
position and
area by color

13. Check direction of parts in emboss taping

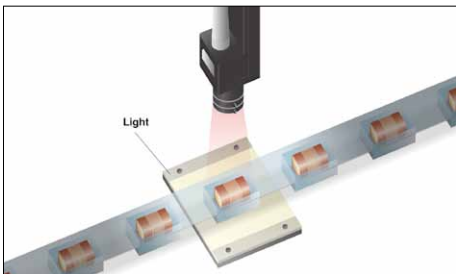

MVS-PM
-Check the
direction by
color pattern
matching

14. Measuring pitch of lead frame

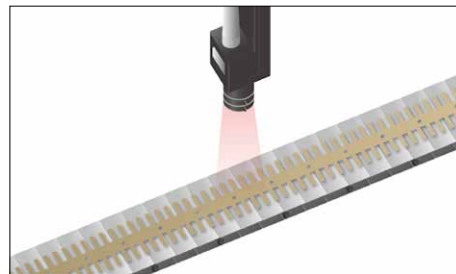

MVS-EM
-Measure the
pitch in Max.,
Min. and
Mean

15. Checking the color of paint on parts

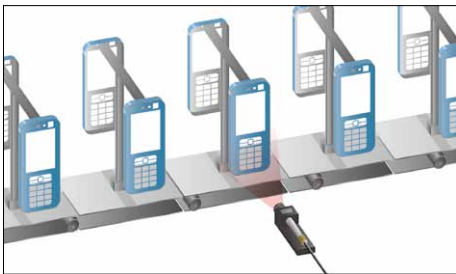

MVS-PM
-Check for
correct color
accuracy and
application

16. Check presence of parts in tooling machine

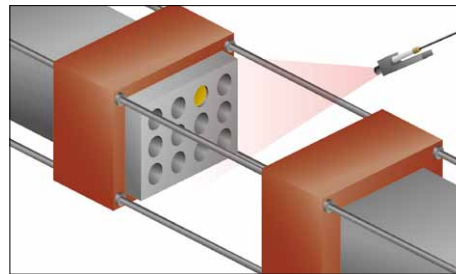

MVS-PM
-Check the
presence of
parts by color
pattern
matching

17. Checking existence of paste on PWB

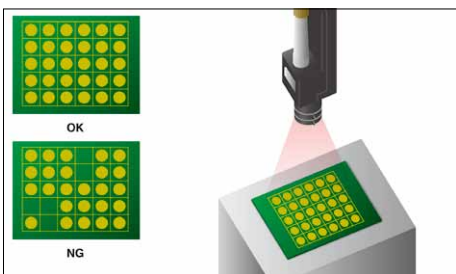

MVS-PM
-Check
existence of
the paste by
pattern
matching

18. Checking surface condition of chip parts

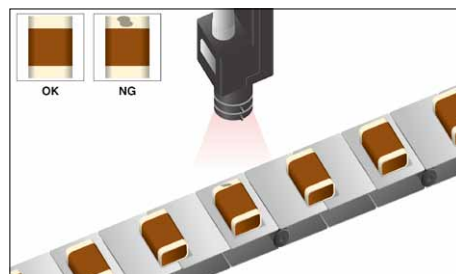

MVS-PM
-Check stain
area on the
surface of the
chip parts

19. Detecting misalignment of material in tooling machine

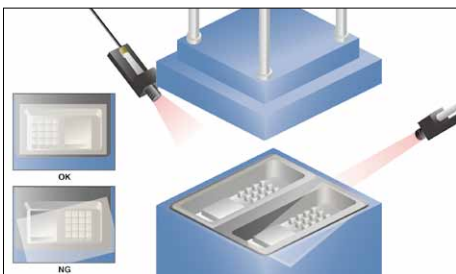

MVS-PM
-Check
material
contour
MVS-EM
-Measure
object
position from
edge

20. Checking shape of emboss taping

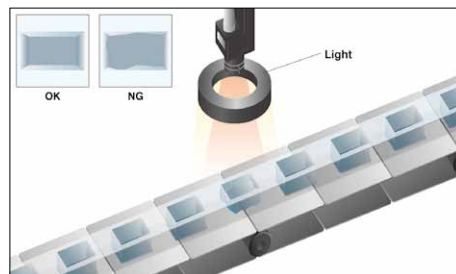

MVS-PM
-Check its
shape by
contour or full
color

21. Checking lead pitch of parts

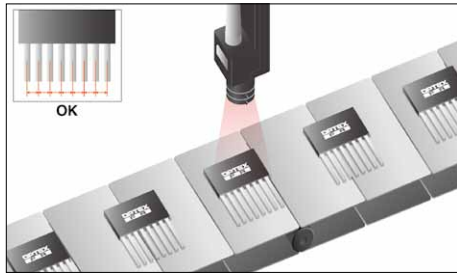

MVS-EM
-Measure pitch of multiple leads in max., min. and mean.

22. Check printing on transistors

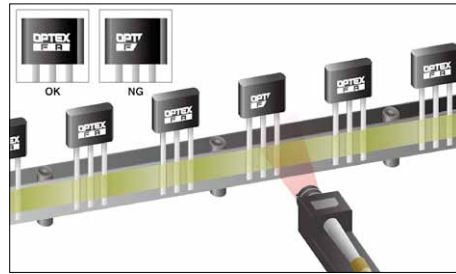

MVS-OCR
-Check the characters printed on transistors

23. Check the marking on chip parts

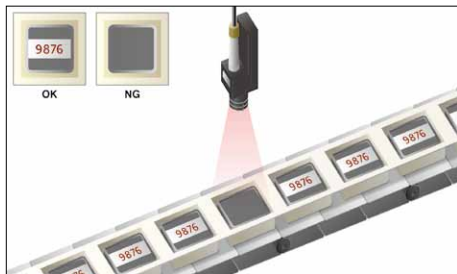

MVS-PM
-Check existence of mark
MVS-OCR
-Check the characters printed on the chip

24. Checking position of orientation flat

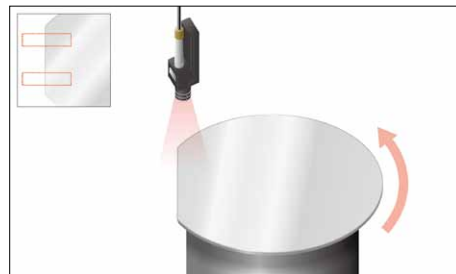

MVS-PM
-Check the area
MVS-EM
-Check the distance between edges

25. Checking existence of solder balls

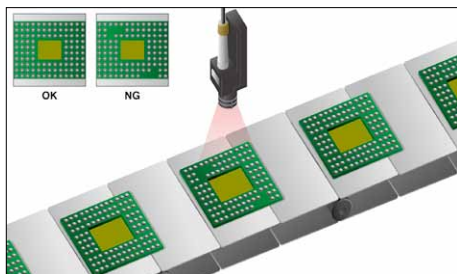

MVS-PM
-Check color area of the solder balls by utilizing multiple inspection windows (max. 16)

26. Checking position of wafer on handling machine



MVS-PM
-Check its position in the inspection window
MVS-EM
-Check the distance between edges

27. Checking wafer position in FOUF



MVS-PM
-Check wafer position by color area utilizing multiple inspection windows (max.16)
MVS-EM
-Check distance between wafers

28. Checking position of reference mark on PWB glass

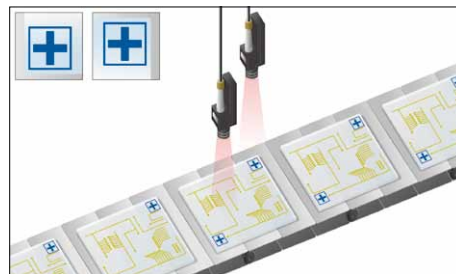

MVS-PM
-Check its position by pattern matching
MVS-EM
-Measure distance between edges

29. Checking condition of vacuum collet tip

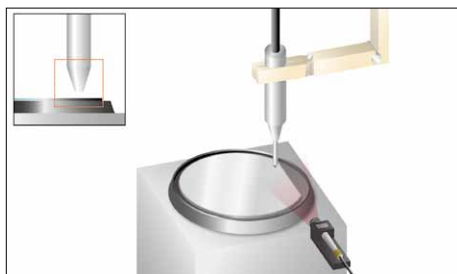

MVS-PM
-Check the shape by pattern matching

30. Checking segments of LCD display

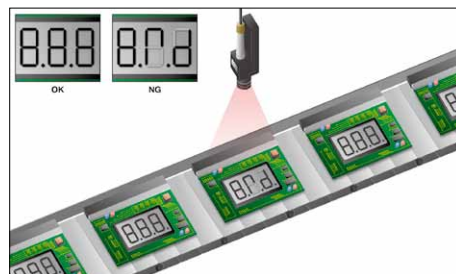

MVS-PM
-Check its condition by contour matching

31. Checking shape of rubber ring

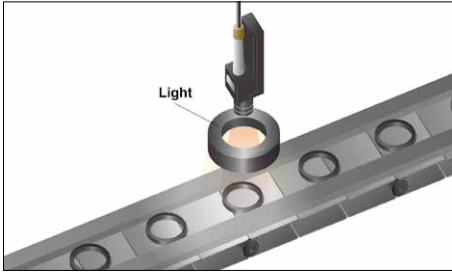

MVS-PM
-Check its shape by pattern matching

MVS-EM
-Measure distance between two outermost and innermost edges

32. Check for the presence of parts and correct order on PWB

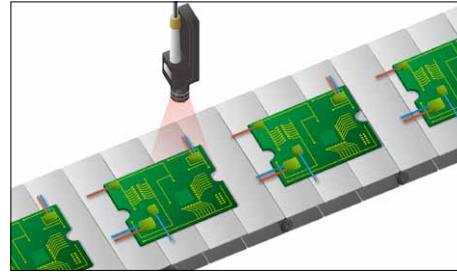

MVS-PM
-Check color area utilizing multiple inspection windows (max. 16)

33. Checking lid alignment

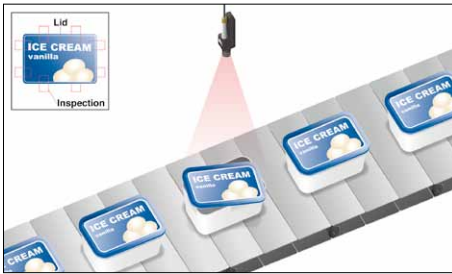

MVS-PM
-Multiple points on the lid are checked to determine alignment

34. Checking shape and printing on milk package

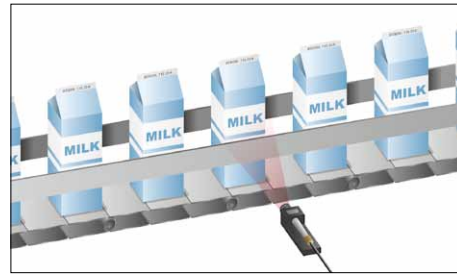

MVS-PM
-Check the shape by its contour or other pattern matching

MVS-OCR
-Check for printing on the package

35. Checking shape of plastic bottles

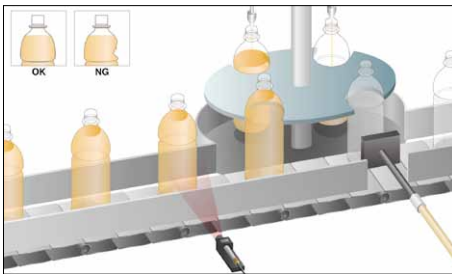

MVS-PM
-Check the shape by contour

36. Checking for label on plastic bottle

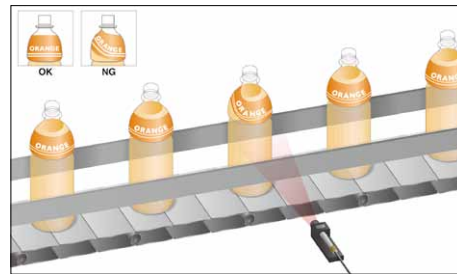

MVS-PM
-Check its position and type by color pattern matching

MVS-OCR
-Check characters printed on label

37. Checking number and type of bottles

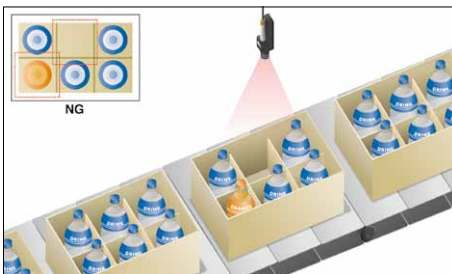

MVS-PM
-Check for presence of each bottle by color pattern matching

38. Checking position and type of pills in dispenser

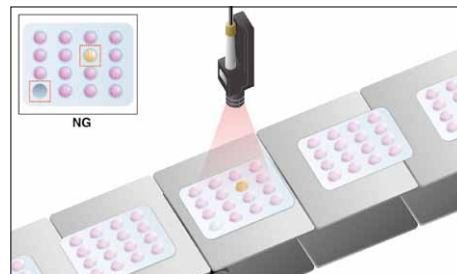

MVS-PM
-Check position and type by color pattern matching

39. Checking level of liquid in bottle

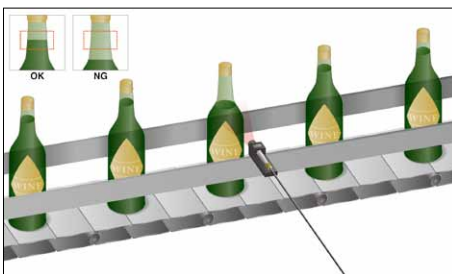

MVS-PM
-Check color area of the liquid in the bottle

MVS-EM
-Measure position of liquid surface in the bottle

40. Checking level of liquid in tube

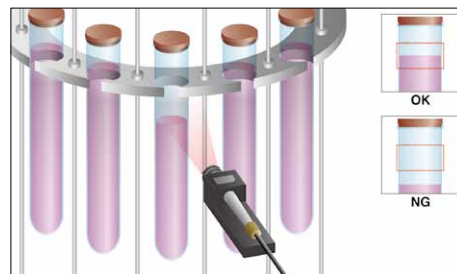

MVS-PM
-Check color area of the liquid in the tube

MVS-EM
-Measure position of liquid surface in the tube

41. Checking characters printed on pouch



MVS-OCR
-Check characters on the pouch

42. Detecting condiments in instant food package

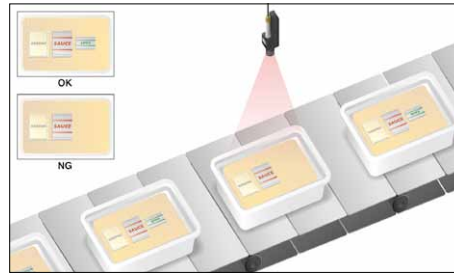

MVS-PM
-Check color area of each condiment

43. Checking characters printed on yogurt lid

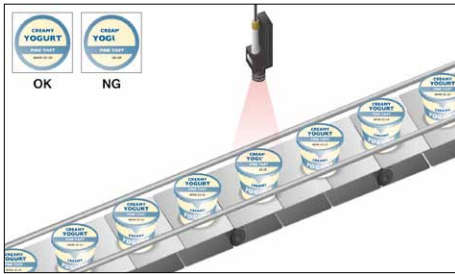

MVS-PM
-Check characters on the lid by color pattern matching
MVS-OCR
-Check characters on the lid

44. Checking existence of blob or stain on a bottle cap

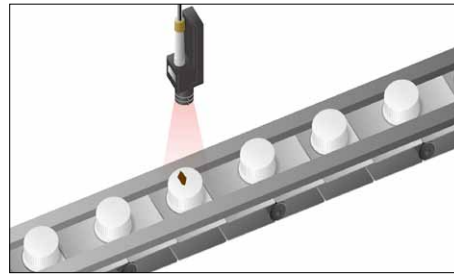

MVS-PM
-Check surface condition by stain area and color area

45. Checking presence of label attached for ad campaign

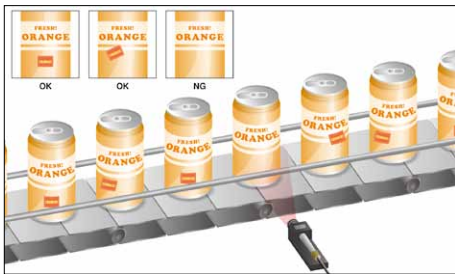

MVS-PM
-Check its position by color pattern matching

46. Checking for characters printed on package

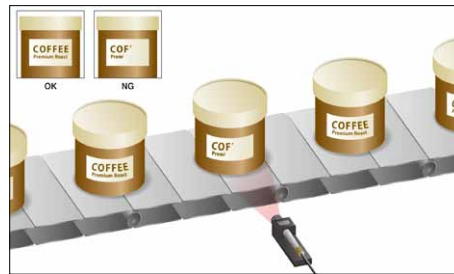

MVS-PM
-Check character by color pattern matching
MVS-OCR
-Check character on the package

47. Detecting defects on bottle

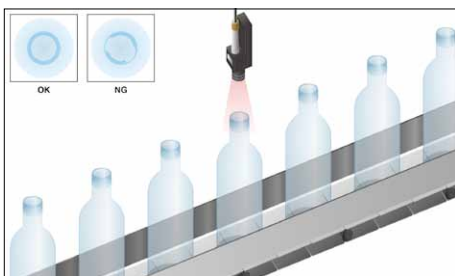

MVS-PM
-Detect defects by checking the contour

48. Checking position of heat sealing on pillow packaging

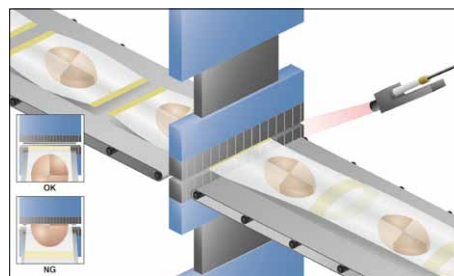

MVS-PM
-Check the position of heat sealing area by color pattern matching

49. Detecting lid position on the bottle



MVS-PM
-Check its position by color pattern matching

50. Checking for correct order in Calendar sorting



MVS-PM
-Check pattern by unique characteristics of each sheet
MVS-OCR
- Check printed characters

51. Checking presence and position of packing tape

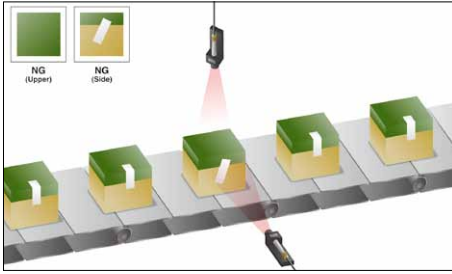

MVS-PM
-Check the position by color pattern matching

52. Sorting objects by shape

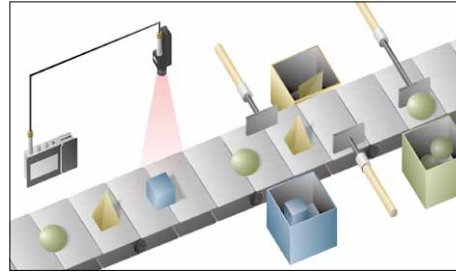

MVS-PM
-Check and sort objects by shape

53. Checking position of printing material

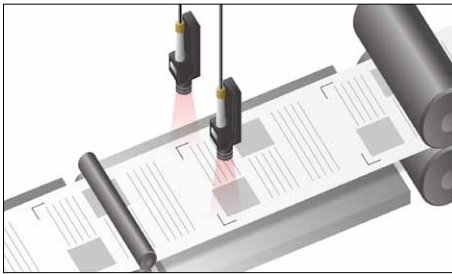

MVS-PM
-Check deviation of the mark from original position

MVS-EM
-Measure position of the mark

54. Measure width of sheet material

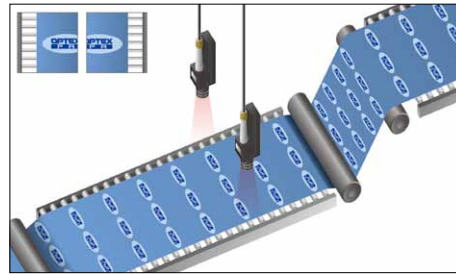

MVS-PM
-Check deviation of the edge from original position

MVS-EM
-Measure position of the edge

55. Measuring dimension of object

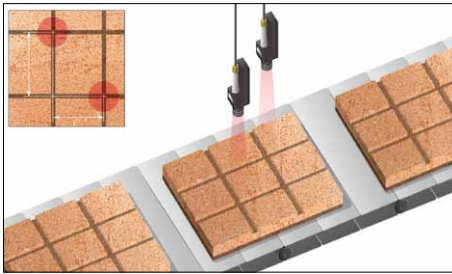

MVS-PM
-Measure distance between two edges

56. Measuring thickness of object

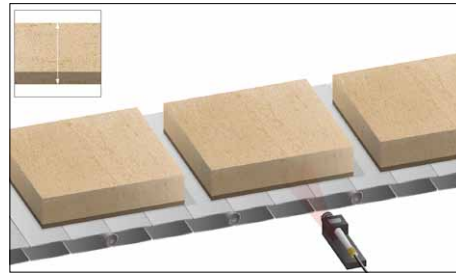

MVS-EM
-Measure distance between two edges

57. Checking size of rubber bank



MVS-PM
-Check area of the rubber

MVS-EM
-Measure distance between two edges of rubber

58. Checking shape and surface condition of plastic parts

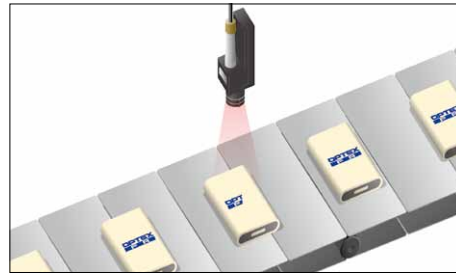

MVS-PM
-Check the shape by contour and check the surface condition by stain area and color area

MVS SERIES LINE UP

PM MVS-PM

Color pattern matching camera unit

Using advanced technology, it is possible to inspect objects fast and reliably. Objects can be inspected for Color, Color and Shape, Blob/Stain, Contour, Differentiation of picture, etc.



Direction of electronic parts

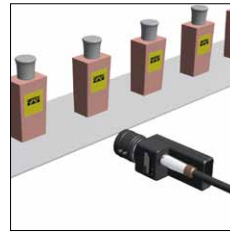

Quality of labeling

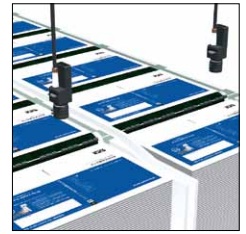

Page order of print

EM MVS-EM

Measurement camera unit

Reliable measurement of length and/or edge count. Measure the distance between edges, measure the pitch of pins, count edges, etc.



Positioning of printed circuit board

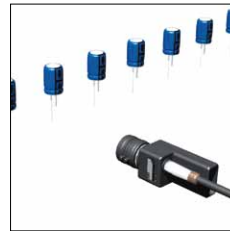

Shape of condenser



Shape of parts for automobile

OCR MVS-OCR

Color OCR camera unit

Inspection of Date, Time and Text. Verification of Expiration date, Time stamp, Lot number or Text.



Shelf life of confection

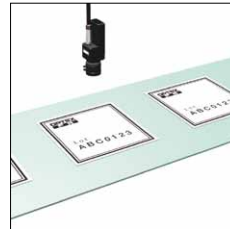

Lot number of labels

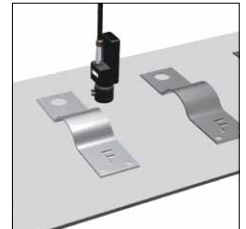

Type mark of parts for automobile

MVS-DN-E

Controller

Connect up to three cameras.
Touchscreen operation.
USB and RS232 interface.
10 key data entry.
Onboard Lighting control.



Backlit buttons show which are active to assist in Setup and Adjustment. Help functions can be accessed at any time by pressing the "?" button

Advanced Technology

High speed vision processing and cost savings

PM EM OCR Original LSI with CPU integrated
ECO-Engine: OPTimum CPU Ver.5

The MVS features an Optex original design LSI with CPU integrated, we were able to integrate the vision process engine into the camera unit. This solution provides high speed image processing and accurate inspection for a variety of applications. Each camera processes the image internally and transmits the result to the controller.



PM EM OCR No change in response speed when operating multiple cameras
Three Cameras inspect independently

We utilized a new technology in the MVS that features low heat generation and low power dissipation. This concept was originally developed for the CVS series as an all-in-one design, the same technique was carried over to the MVS. There is no change in the response time when multiple cameras are used. The all-in-one design allows the camera to operate independent from the controller.



PM EM OCR Integrated system technology
High Performance, Easy Installation and Low Cost

The controller has a built-in touchscreen interface, full color display and ten-key input panel. A power supply for control of the external lighting is also integrated into the controller. Simply connect the cameras and lights to the controller. There is no need for a console, external monitor or a separate power supply for lighting.



PM EM OCR Support is available from LED lighting to training

Lighting is the single most important factor to capturing a good quality image for inspection. Optex FA offers a complete selection of lighting options. We can provide customer support for the selection of lighting, lenses, and training.



PM EM Up to 16 inspections can be done at the same time with one Camera 16 Inspection windows are available for each Camera

Each Camera can have a maximum of 16 inspection windows in one Bank of memory. Each inspection window can be set to inspect a different feature based on 6 inspection functions. The inspection judgment output for each inspection window can be output through the 50 pin I/O connector.

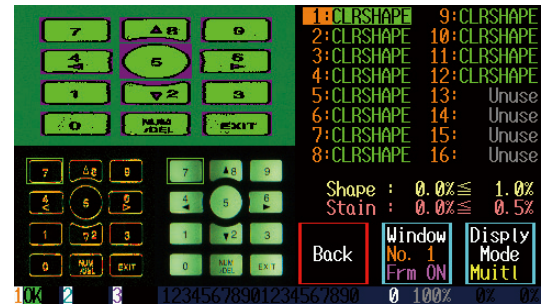

OCR Up to 4 inspection windows

The parameters for each inspection window can be individually set.

Up to 2 Forms of each Date and Time are available for one window and up to 4 Forms of strings are available(max. total of 4 Forms).

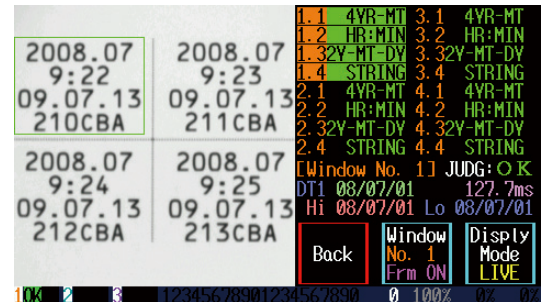

PM EM OCR Quick change over 32 Banks are available for one Camera

You can remotely select the bank to use by using a controller, PLC or the RS-232C I/F. The setup parameters for each bank are stored in memory and can be recalled when the product is run again.



PM EM OCR Lighting control without the need of a separate power supply Controller has LED lighting control built in

Support for a total of three LED lights(12VDC, 24W total)is available.

The output connector for the power source is a quick connect/disconnect type.

The intensity level for each light can be adjusted separately.



For stable inspection and better process yield 5 functions are available

Continuous capture

When the camera checks the image it will automatically check up to 5(EM) or 6 images(PM/OCR), looking for a good reading. This insures stable operation if the trigger is not stable or the position of the object changes slightly. If the result is found to be OK the inspection will stop prior to reaching the maximum number of inspections.

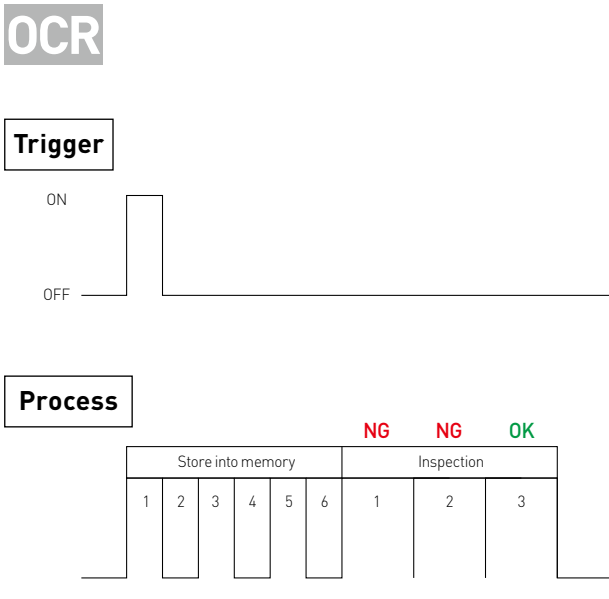
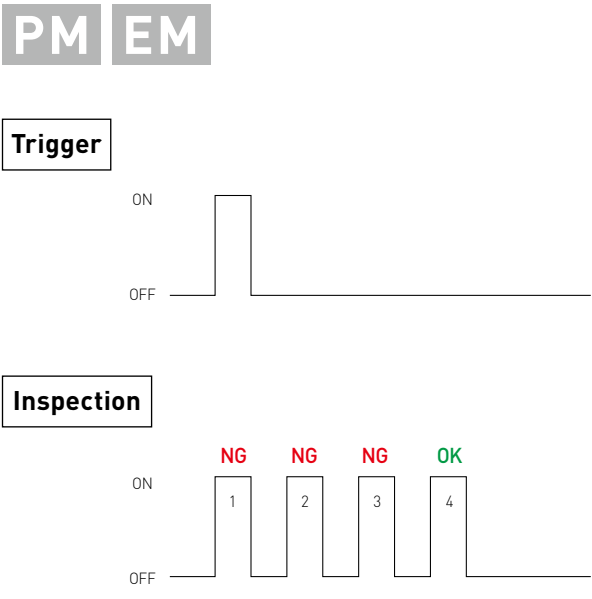

PM EM OCR Variable shutter speed

When the camera is checking image using the Continuous Capture feature the shutter speed will automatically be adjusted up to +36% ~ -24%. This compensates for changes in the lighting.

PM EM OCR Search function

The images is searched not only in the X and Y direction but it also can be rotated up to +/- 180 degrees (PM/OCR) or +/- 45 degrees(EM). This is useful when the position or orientation of the object changes.

PM Scaling up/down

When the camera is checking the image using the Continuous Capture feature the image will automatically be scaled Up/Down by up to +/-6%. This compensates for changes in the distance between the camera and object.

PM OCR Dark Compensation

For reliable inspection of color, the hue of each pixel is calculated. This function insures that captured images are stable even with variations in lighting or when the distance to the target changes.

When the light is from the top

The MVS calculates the hue of each pixel so it can get a homogenous color for each pixel. Regular vision sensors simply adjust the brightness so the upper part is brighter than the lower part.



When a bright ambient light is present

The MVS can get a homogenous color for each pixel even if the object has an area which is brighter due to external ambient light.

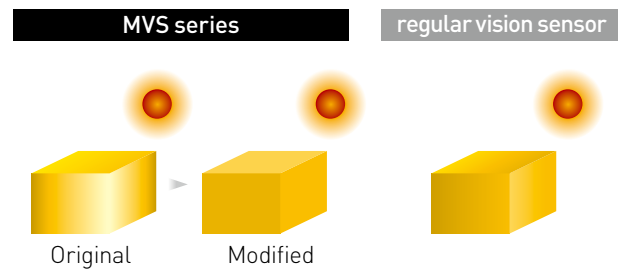

When the distance varies

The Dark Compensation function is effective when the object distance varies and its brightness changes.



When the object is glossy

The Dark Compensation function helps to reduce bright spots on glossy surfaces.

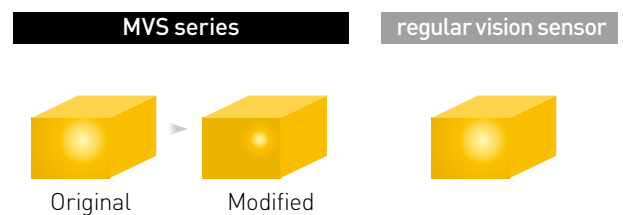

Simply follow the explanation on the display
Fast and easy "SETUP Menu"

Concept : No operating manual required



button leads you to the SETUP menu where each step is clearly described.

Following is example of MVS-PM SETUP Menu



1. Touch[Setup]button



2. Select "Bank" and "Trigger mode"

3. Adjust shutter speed



4. Adjust brightness and direction of the image

5. Storing captured image



6. Select Color mode or Black and White mode



7. Determine search area and its function



8. Setup inspection windows

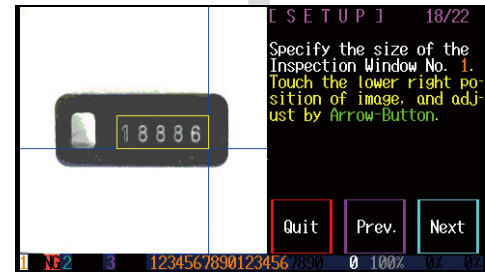

9. Setup inspection function

Select function from
 Stain/Color Area/Full Color/Differential/Contour/Color Shape

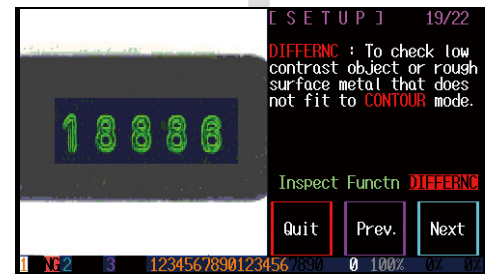

10. Touch[Finish]to exit setup menu



Inspection for Color, Flaw, Blob, Shape, etc. 6 inspection modes are available

Stain

The camera compares the differential ratio of the stored master image with the differential result of the target image to determine the Stain value.

When this value exceeds the upper limit or is less than the lower limit, it is defined as NG.

This is used to detect the presence of stain (flaws) on the surface of metal objects or defects in plastic materials.

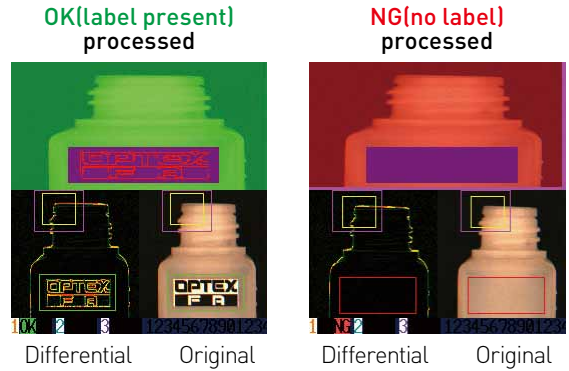

Contour

The camera compares the contour of the stored differential master image with the contour of the target object. It counts the number of pixels that do not match the Target contour to determine the Contour value (Lack of pixels). It counts the number of pixels outside of the Target contour area (background) which have the selected color to determine the Stain value. If either value exceeds the threshold, it is defined as NG. This function is used when the contrast of the target object is high and inspecting the contour produces a more accurate result.

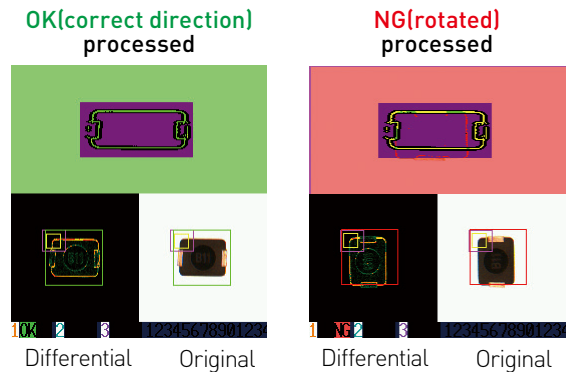

Differential

The camera compares the stored differential master image with the target object. If the difference exceeds the threshold it is defined as NG.

This function is used to inspect metal parts with uneven lighting. It is not good for detecting color or its depth.

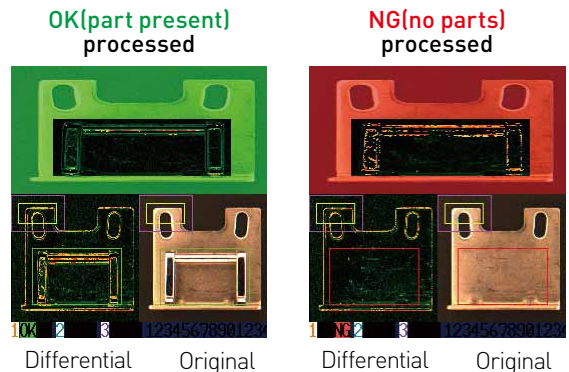

Color Shape

The camera inspects the shape of the area that contains the selected color.

It counts the number of pixels that have a different color in this area to determine the Contour value (Lack of pixels). It counts the number of pixels outside of the area (background) which have the selected color to determine the Stain value.

If either value exceeds the threshold, it is defined as NG. This is used when the target color is close to the background and is difficult to inspect by its contour or differential image. This is not good for checking black and white objects.

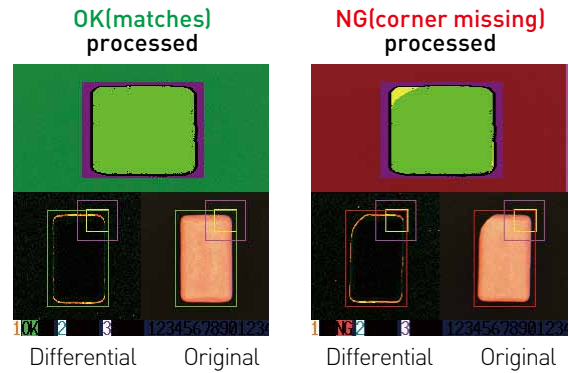

Color Area

The camera calculates the ratio of the number of pixels that have the selected color to all the pixels in the inspection window. When it exceeds the upper limit or is less than the lower limit, it is defined as NG.

This is used to detect color differences, especially when the color is not stable and that there is no need to detect object shape.

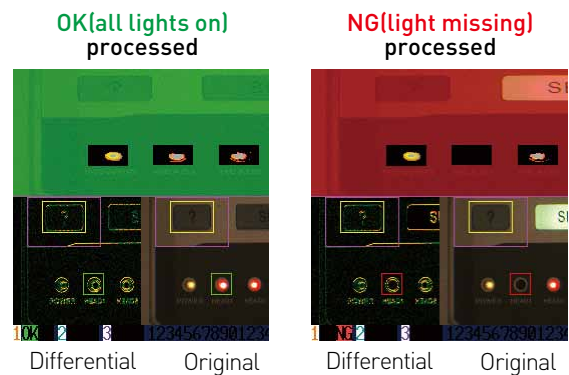

Full Color

The camera will compare the difference between the full color image of the target and the stored image.

If the sum of the difference exceeds the threshold value it is defined as NG.

This is used to inspect color and depth of pictures and prints under stable lighting.

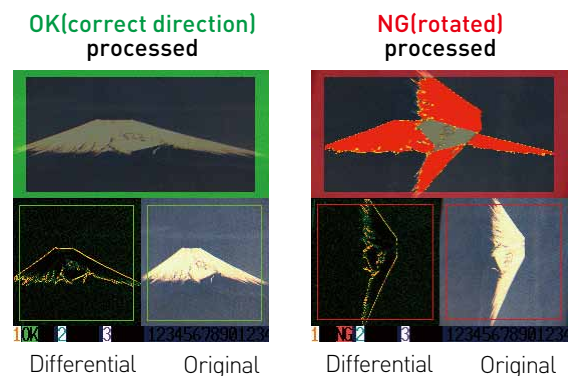

Measurement of Inner / Outer Dimension, Edge position, Counting edges, etc.

6 inspection modes are available

Outer Dimension

The camera measures the distance between the two outermost edges.

Choose between the longest, shortest or the mean value in the selected inspection window.

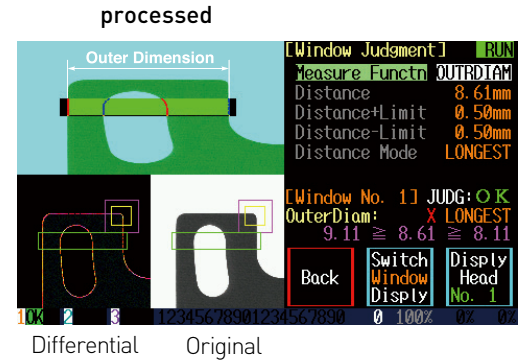

Inner Dimension

The camera measures the distance between the two innermost edges.

Choose between the longest, shortest or the mean value in the selected inspection window.

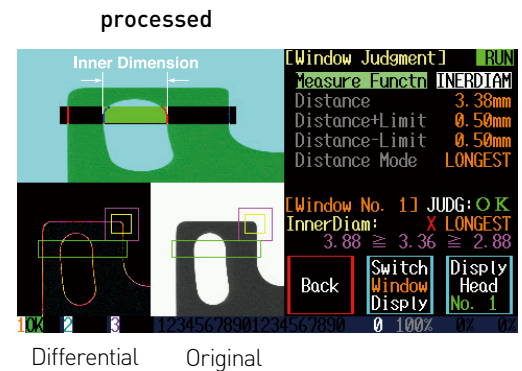

Position

Measures the distance between two edges in two different inspection windows. This function is useful for detecting the displacement of edges. Choose between the longest, shortest or the mean value in the selected inspection window.

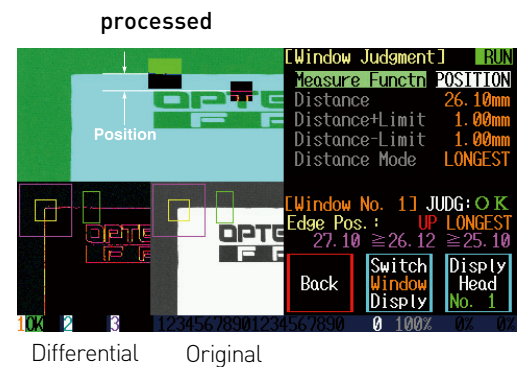

Number of Edges

The camera counts the number of edges in the inspection window. Choose the edges to count based on the transition of light to dark, dark to light or all of the edges.

In the processed image, a red line means a light to dark transition and a blue line means dark to light.

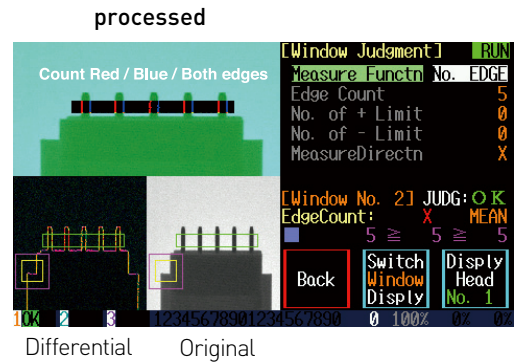

Multiple Edges

The camera measures the distance between edges in the inspection window. Choose the edges of a light part (blue line to red line) or a dark part (red line to blue line).

It judges by longest limit, shortest limit or the mean value.

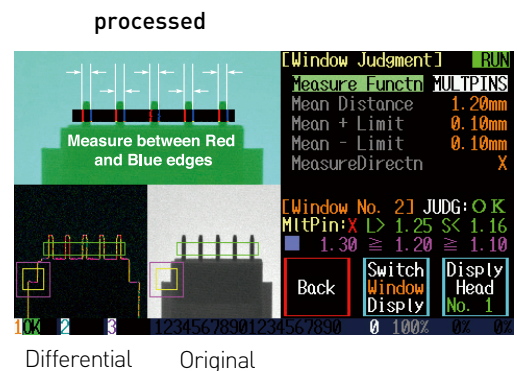

Center Pitch

The camera measures the pitch between the centers of the edges in the selected inspection window.

It judges by longest limit, shortest limit or the mean value.

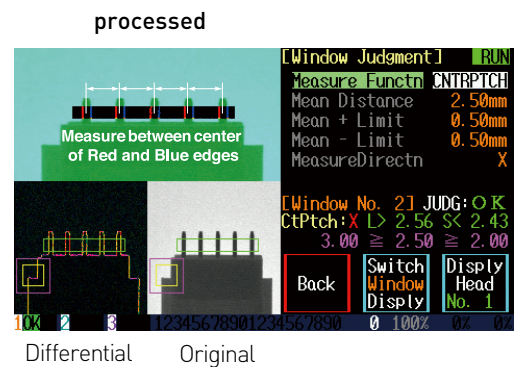

MVS-OCR FEATURE

Optical Character Recognition Recognizes Alphabetic, Numeric and Special Characters

Standard dictionary characters intergrated

0 ~ 9 A ~ Z . / :

User defined characters can be loaded

! # \$ % & () * + - ; < = > ? @ [] ^ _ ` a ~ z ~

All the characters are correct : OK
One character is not correct : NG

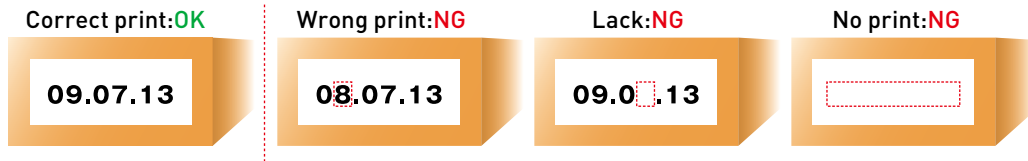

Error level can be set

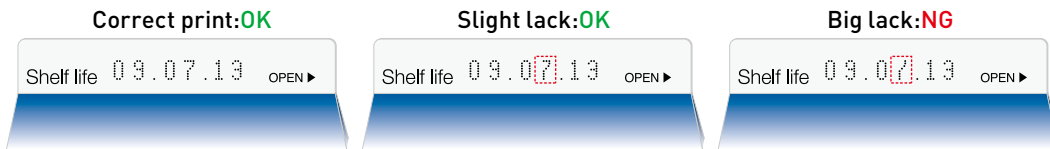

Recognizes various printer fonts

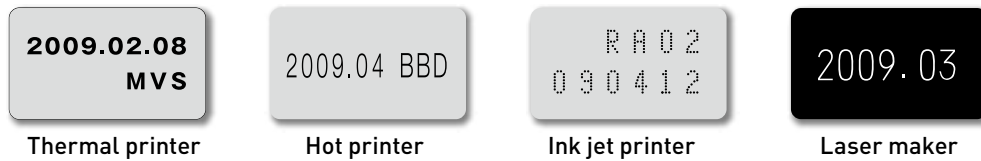

Change the image direction

The image direction for each bank can be set. This makes it possible to read reverse printed characters such as printing on the opposite side of a transparent sheet.

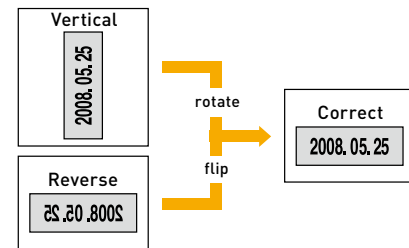

Recognize connected characters

Characters that are connected can be separated by adjusting the character width.

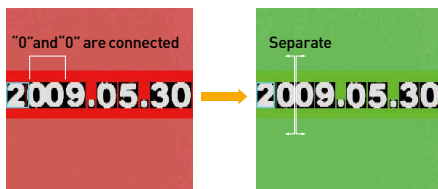

Built-in Calendar

The date and time are automatically updated.
The tolerance of the date and time transition timing can be set.

Tolerance per character

The tolerance for each character can be set (ex. the numbers "6" and "8" are very close in shape and need to be checked closely).



OCR regardless of color

The MVS-OCR is able to detect characters regardless of the color of the background.

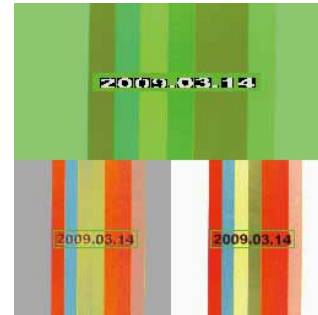

Search function

The MVS-OCR is able to search in both the X and Y directions, it also can do a rotational search of +/- 0-180 degrees. Fullcolor pattern matching and matching of extracted character modes are available.

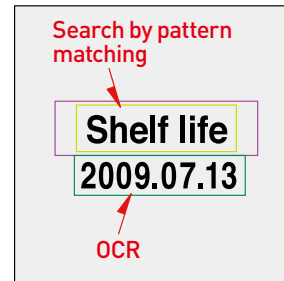

User defined characters

The MVS-OCR can recognize lower case letters and special symbols defined by the user dictionary. For example it can be used to distinguish between "H" and "M" when the font that is used makes these letters hard to distinguish.

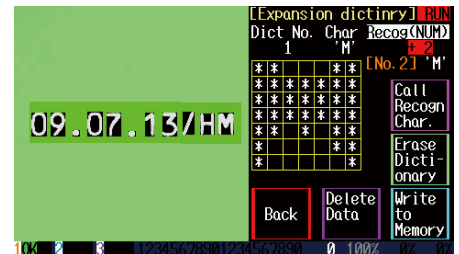

Code recognition

It can recognize Code of Month/Date/Hour/Minute. Example: "CAO H" → "March 15th, 7 O'clock"

Conversion list example

You can modify on the controller.

Month	Date	Hour	Minute
1 A	1 AA 11 AK 21 AU	0 A 12 M	0 A C E G I K
2 B	2 AB 12 AL 22 AV	1 B 13 N	1 A C E G I K
3 C	3 AC 13 AM 23 AW	2 C 14 O	2 A C E G I K
4 D	4 AD 14 AN 24 AX	3 D 15 P	3 A C E G I K
5 E	5 AE 15 AO 25 AY	4 E 16 Q	4 A C E G I K
6 F	6 AF 16 AP 26 AZ	5 F 17 R	5 B D F H J L
7 G	7 AG 17 AQ 27 BA	6 G 18 S	6 B D F H J L
8 H	8 AH 18 AR 28 BB	7 H 19 T	7 B D F H J L
9 I	9 AI 19 AS 29 BC	8 I 20 U	8 B D F H J L
10 J	10 AJ 20 AT 30 BD	9 J 21 V	9 B D F H J L
11 K	31 BE	10 K 22 W	+00 +10 +20 +30 +40 +50
12 L		11 L 23 X	

Useful support functions aid in operation 5 support functions

Trouble Shoot

Troubl Shoot-ing button leads you to the Trouble Shooting menu. From this menu, you are able to view what corrections need to be done.

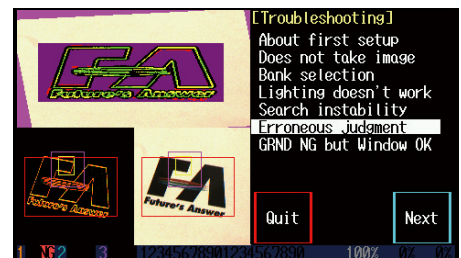

Help function

? button on the ten-key panel shows what the parameter means and what adjustments can be done.



Auto Threshold setting

Sample a good object to reset the threshold value. The level of accuracy can be selected from the sampled data.

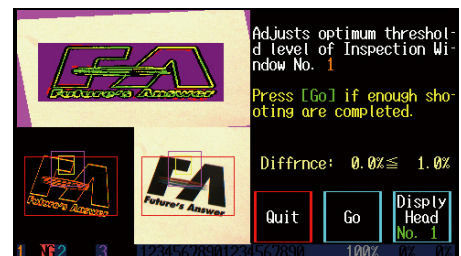

Offline analyzer

Offlne Analy-zer button leads you into offline analyzer menu. You can load the NG image and investigate why the image was NG, you can also try changing parameters with the NG image to correct the problem.

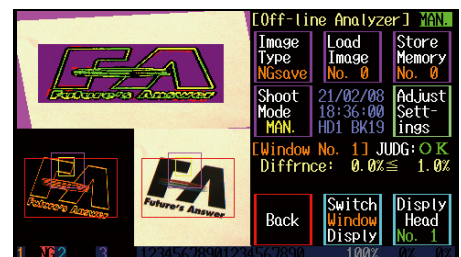

Storing NG images

The controller stores up to 63 NG images in memory (after the 63rd image the controller will re-start at beginning overwriting the oldest images). You can also download the images into a PC and use these for troubleshooting or e-mail to Optex-FA tech support.

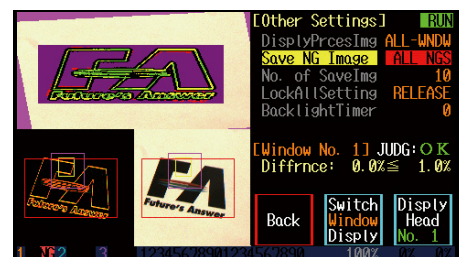

Camera unit



Model No. : MVS-PM/MVS-EM/MVS-OCR
 Image sensor : CCD(color)
 Capture mode : Color/Monochrome

*lens is not included
 Please order separately

Controller



Model No. : MVS-DN-E
 Camera No : Max 3
 I/F : Touch panel display,
 Ten-key
 Ethernet

*PNP output type is MVS-DP-E

CCTV Lens (C mount)



Model No. : FASV-03514
 Focal Length : 3.5mm
 F No. : F1.4
 Filter size : -



Model No. : FASV-F1614
 Focal Length : 16mm
 F No. : F1.4
 Filter size : M27 P0.5



Model No. : FASV-F0814
 Focal Length : 8mm
 F No. : F1.3
 Filter size : M27 P0.5



Model No. : FASV-F2516
 Focal Length : 25mm
 F No. : F1.4
 Filter size : M27 P0.5



Model No. : FASV-F1214
 Focal Length : 12mm
 F No. : F1.4
 Filter size : M27 P0.5



Model No. : FASV-F5020
 Focal Length : 50mm
 F No. : F1.8
 Filter size : M30.5 P0.5

Camera cable

MVS-C25 : 2M Cable
MVS-C5S : 5M Cable
MVS-C5E : 5M Extension Cable
MVS-C5SR : 5M Robotic Cable
MVS-C5ER : 5M Extension Robotic Cable
MVS-C5W : 5M Cable with wiring for light
 (need MVS-LC05)

External light



Model No. : OPR-S55-28W
 Method : Direct ring
 Spec : White LED/
 DC12V, 5.1W
 Cable : 500mm

Polarizing filter



Model No. : FASV-PL270-RS
 size : M27 P0.5



Model No. : FASV-PL305-RS
 size : M30.5 P0.5

IR cut filters



Model No. : FASV-IR270
 size : M27 P0.5



Model No. : FASV-IR305
 size : M30.5 P0.5

Filters for light

PL-OPR-S55-28 : Polarizing filter for
 OPR-S55-28
DF80-OPR-S55-28 : Diffuse filter (80%) for
 OPR-S55-28

Light holder

OPAU-150A : Mounting bracket accessory
 for use with OPR-S55-28W

Cable for light

MVS-LC05 : Controller to lighting connection
 cable, 500mm length



OP-CB1-2 : 2m Extension cable for light
OP-CB1-3 : 3m Extension cable for light
OP-CB1-5 : 5m Extension cable for light

Extension ring set

Model No. : FASV-EXR-LT2
 5 piece set



0.5mm



1mm



5mm



10mm



20mm

I/O Connector cable



MVS-C310 : 3m IEEE1284 half pitch 50p

Touch panel protective sheet

MVS-TP

Mounting bracket for light

BKT-MVS-OPR : Mounting bracket for OPR-S55-28W



DIMENSIONS

Camera unit

Model No. : MVS-PM / MVS-EM / MVS-OCR

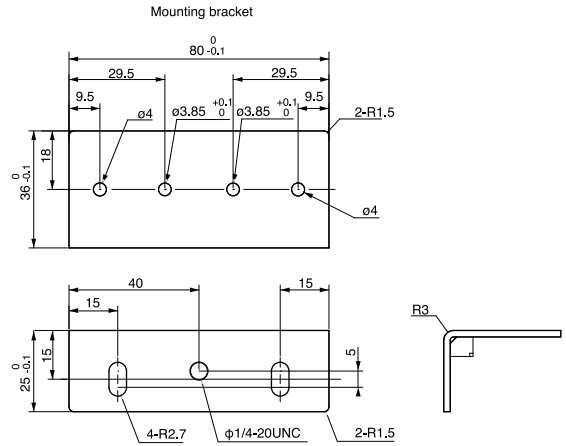
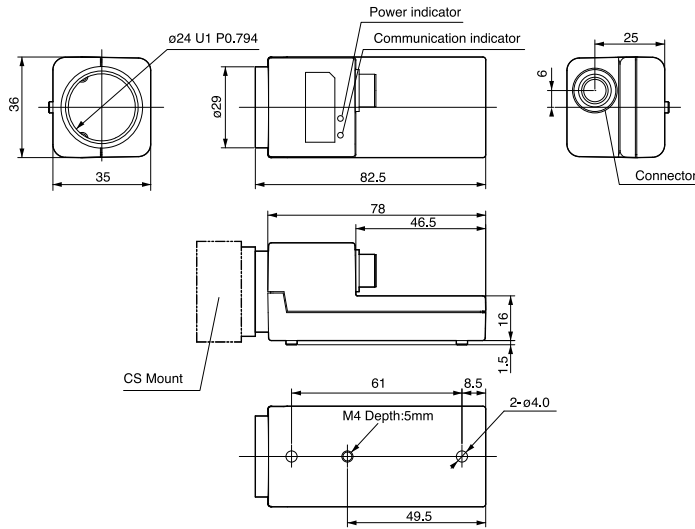

Controller

Model No. : MVS-DN-E

Panel mount adaptor installation

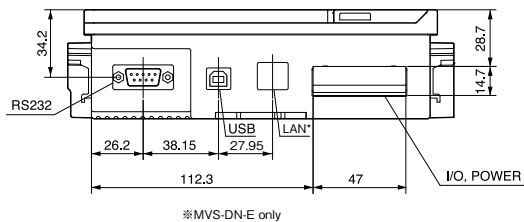
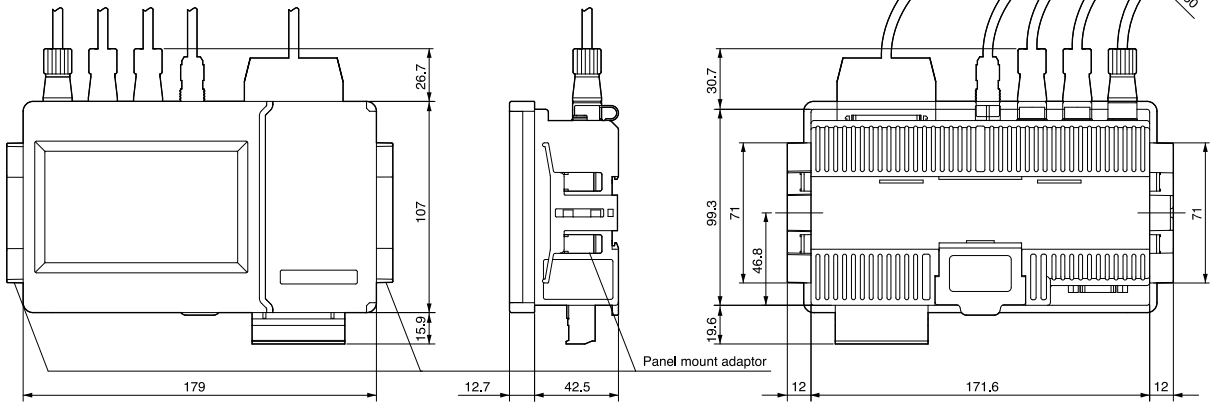
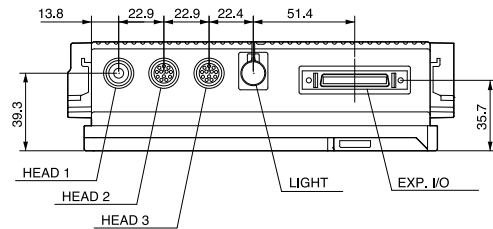

※MVS-DN-E only

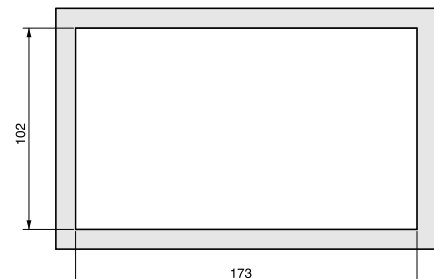

Recommended opening for mounting

Lens

Model No. : FASV-03514
Focal Length : 3.5mm

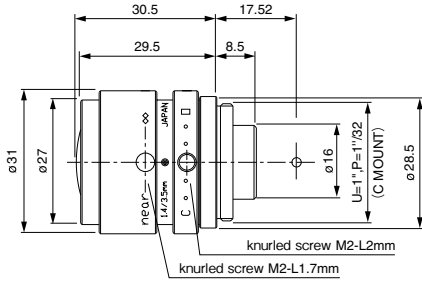

Model No. : FASV-F0814
Focal Length : 8mm

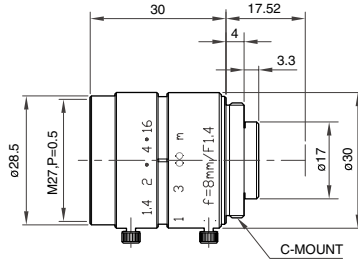

Model No. : FASV-F1214
Focal Length : 12mm

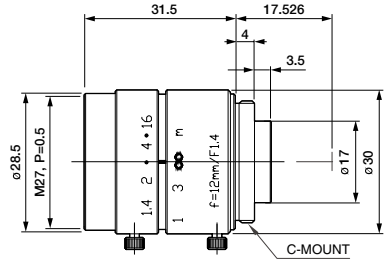

Model No. : FASV-F1614
Focal Length : 16mm

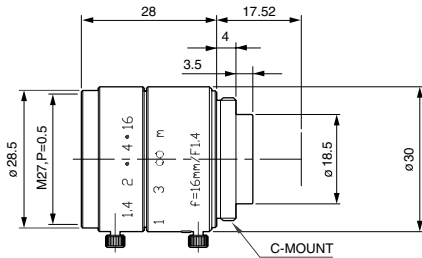

Model No. : FASV-F2516
Focal Length : 25mm

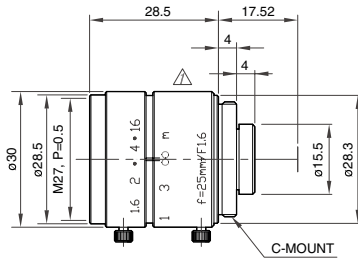

Model No. : FASV-F5020
Focal Length : 50mm

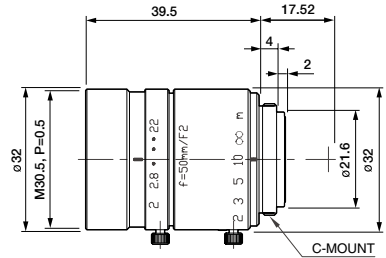

Extension ring set

Model No. : FASV-EXR-LT2

0.5mm - 1.0mm

5mm - 20mm

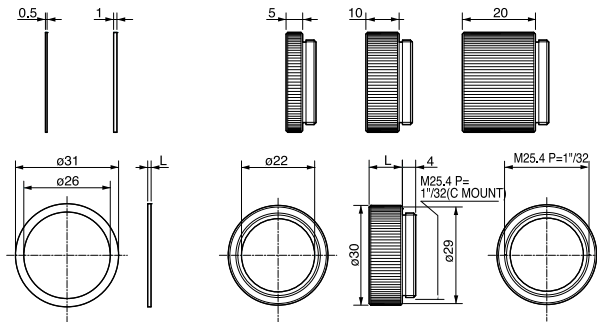

Polarizing filter

Model No. : FASV-PL270-RS
(A) size : M27 P0.5

Model No. : FASV-PL305-RS
(A) size : M30.5 P0.5

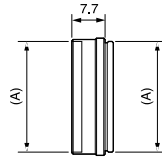

IR cut filters

Model No. : FASV-IR270
(A) size : M27 P0.5

Model No. : FASV-IR305
(A) size : M30.5 P0.5

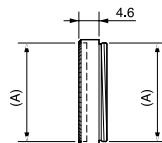

External light

Model No. : OPR-S55-28W

Model No. : DF80-OPR-S55-28
Diffusing plate

Model No. : PL-OPR-S55-28
Cover plate
t=1.8

Polarizing filter
t=0.2

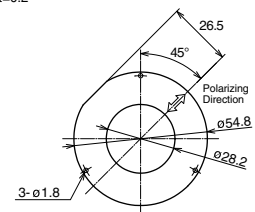
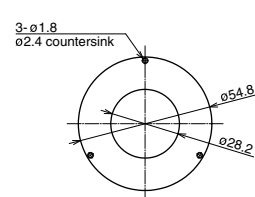
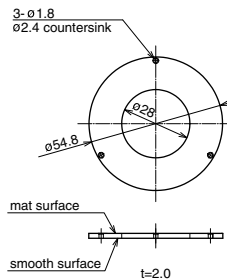
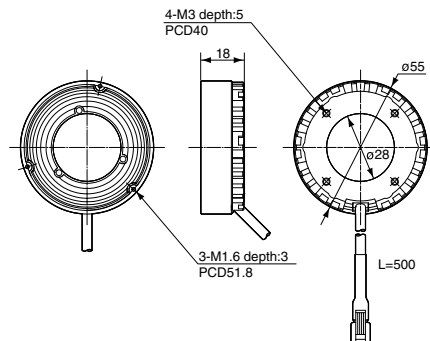

SPECIFICATIONS

MVS Series

CVS Series

MVS Series APPLICATION

MVS-PM/EM

MVS-OCR

OPTIONS

Model	MVS-PM MVS-EM Common Specifications
Supply Voltage	DC 6V ±10% (From Controller)
Power consumption	Max. 100mA / 24V DC (in Controller)
Image sensor	430000 Pixel 1/3" CCD Color Image Sensor
Resolution	512 X 512 (512 X 256 by interlace processing)
Pixel size	H: 6.5 X V: 6.3µm (512 X 512 => 3.33 X 3.23 mm)
Lens type	CS mount (C mount adapter is included)
Communication I/F	LVDS (100Mbps) dedicated to Controller (Max. 10m)
Indicator	LED (Power, Status)
Operating Temp., Humid.	0-50°C, 35-85%/RH (Non Condensing)
Storage Temp., Humid	-20-70°C, 25-95%/RH (Non Condensing)
Vibration, Shock	Vibration : 10~ 55Hz /1.5mm, Shock : 15G
Conformity	CE (EN55011 Class-A, EN61000-4-2-6), RoHS
Material	Aluminum
Protection Category	IP50
Weight	Approx. 90g
Accessories	C mount adapter, mounting bracket

Model	MVS-PM Specifications
Image processing function	<ul style="list-style-type: none"> - Rotation Search up to +/- 180 degree - 16 Inspection Window - Judgment of Contour and Background, Color Normalized Correlation, Differential Normalized Correlation, Color Shape, Color Area, Stain - Variable shutter speed with continuous capture (up to 6 times) - Automatic Color/Black&White changeover - External Teaching (Auto-Shutter/Threshold/Color Extracting)

Model	MVS-EM Specifications
Measurement function	<ul style="list-style-type: none"> - Rotation Search up to +/- 45 degree - 16 Inspection Window - Measuring Outer/Inner size, Counting number of Edges, Measuring position of Edge, Measuring Edge to Edge, Measuring pitch of Edges - Variable shutter speed with continuous capture (up to 5 times) - Black&White capturing - External Teaching (Auto-Shutter/Threshold/Auto function selection)

Model	MVS-OCR Specifications
Supply Voltage	DC 6V ±10% (From Controller)
Power consumption	Max. 100mA / 24V DC (in Controller)
Image sensor	430000 Pixel 1/3" CCD Color Image Sensor
Resolution	512 X 512 (512 X 256 by interlace processing)
Pixel size	H: 6.5 X V: 6.3µm (512 X 512 => 3.33 X 3.23 mm)
Lens type	CS mount (C mount adapter is included)
Communication I/F	LVDS (100Mbps) dedicated to Controller (Max. 10m)
Indicator	LED (Power, Status)
Response time	Approx. 45ms
Operating Temp., Humid.	0-50°C, 35-85%/RH (Non Condensing)
Storage Temp., Humid	-20-70°C, 25-95%/RH (Non Condensing)
Vibration, Shock	Vibration : 10~ 55Hz /1.5mm, Shock : 15G
Conformity	CE (EN55011 Class-A, EN61000-4-2-6), RoHS
Material	Aluminum
Protection Category	IP50
Weight	Approx. 90g
Accessories	C mount adapter, mounting bracket
Image processing function	<ul style="list-style-type: none"> - Rotation Search up to +/- 180 degree - 4 Inspection Window - Up to 6 lines and up to 60 characters per one inspection window. - Up to 2 DATE and 2 TIME and 4 strings (total 4) - Maximum of 250 user defined characters - Available Date/Time code recognition: Month: 1 character, Date: 2 char., Hour: 1 char., Minutes: 1 char. - Variable shutter speed with continuous capturing (up to 6 times) - Automatic Color/Black&White changeover - External Teaching (Auto-Shutter/Threshold/Color Extracting)

SPECIFICATIONS

Model	MVS-DN/DP/DN-E/DP-E
Supply Voltage	DC 24V ±10% (DC 12V is possible without external Light)
Power consumption	Controller : Max. 80mA / 24V DC, With external light : max 1.5A (150% of Light power consumption)+ Power consumption of all camera heads
Number of camera	Max. 3 heads
Output	NPN/PNP open collector Residual voltage is less 1.0V, OK, NG : 1 each for every camera head (Total: 6) max. 100mA, Auxiliary output : Total 20, max. 50mA
Input	Synchronous: 3, Auxiliary: 10
I/O connector	Power/OK/NG/Synchronous : Terminal block 12P, Expansive I/O : IEEE1284 half pitch connector 50P
External Light out	12V PWM control (87kHz, 256steps) Out: 3, Total 24W
Communication I/F	USB1.1 (max 12Mbps) : USB standard connector, RS232 (max 500kbps) : D-Sub 9P, RJ45 (8P8C) : Ethernet (10BaseT/100BaseTX) MVS-DN-E / DP-E only
Display, Control device	4.3" wide TFT LCD, Touchscreen, Panel SW, Indicator : Power, Camera No.LED
Timer accuracy	-45sec. ~ +1min. 15sec. Per Month (Typical)
Timer backup battery	primary cell : 5 year with power off (Typical), secondary super capacitor : 7.8 year (Typical with 3 days backup)
Operating Temp., Humid.	0~50°C, 35~85%/RH (Non Condensing)
Storage Temp., Humid	-20~70°C, 25~95%/RH (Non Condensing)
Vibration, Shock	Vibration : 10~ 55Hz /1.5mm, Shock : 10G
Approvals	CE (EN55011 Class-A, EN61000-4-2~6), RoHS
Material	polycarbonate
Protection	IP20
Weight	Approx. 570g
Attachment	Panel mount bracket

WORKING DISTANCE vs. FIELD OF VIEW

Camera Working Distance L (mm)

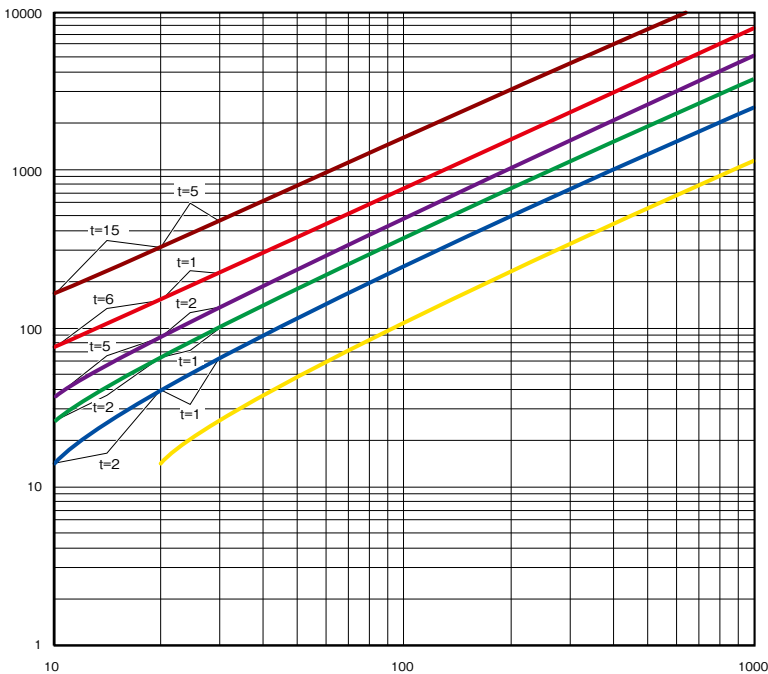

"t" indicates thickness of Extension ring to use (mm)

Lens	Model
—	FASV-03514
—	FASV-F0814
—	FASV-F1214
—	FASV-F1614
—	FASV-F2516
—	FASV-F5020

How to utilize the graph

1. Determine Working distance (L) and Field of view (A).
2. Choose the appropriate lens and extension ring according to the graph.

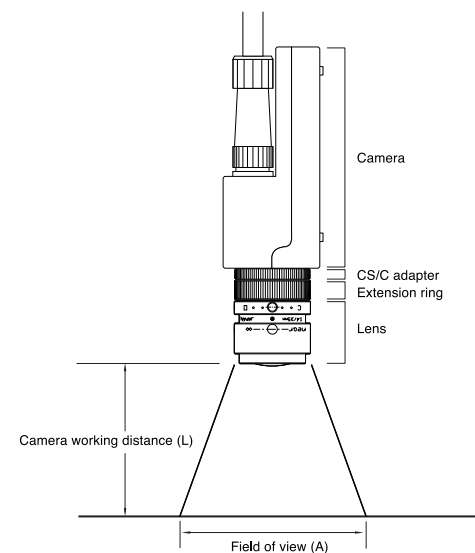

CVS SERIES APPLICATION

1. Checking existence of printing on the box

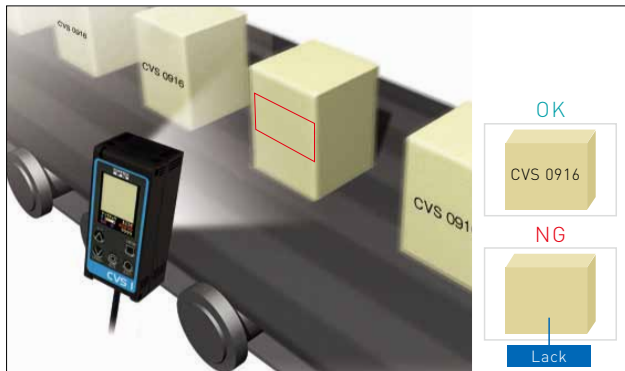

CVS1-R

Set the extracted color from the printing and check its area in the field of view

2. Checking the lid of instant foods



CVS2-R

Check the color and shape by its pattern matching function

3. Checking existence of cutting tape on the film



CVS1easy-R

Set the extracted color from the cutting tape and check its area in the field of view

4. Checking multiple colors on the box



CVS2-R

Check existence of multiple color on the box registering multiple colors as reference

5. Checking existence of seasoning bag



CVS1-R

Set the extracted color from the seasoning bag and check its area in the field of view

6. Checking shelf life on the packaging film



CVS4-R

Check the date of shelf life on packaging film. It has calendar function so checking overnight is available

7. Checking existence of label on package



CVS1-R

Set the major color on the label and check its area in the field of view

8. Checking existence of label on bottle



CVS1-R + CVS-LU1

Check the color of fluorescent illuminated by UV light utilizing CVS-LU1

9. Checking shelf life on the milk package



CVS4-R

Check the date of shelf life on milk package. It has calendar function so checking overnight is available

10. Checking expiration date on the package



CVS4-R

Check the expiration date on the package. It can just check number of character as well

11. Checking existence of description of pills



CVS1-R

Set the color area of description of pills in the field of view

12. Checking overlapping of the label



CVS3-R

Check the overlapping label by its edge detection function

13. Checking marking on electric components



CVS1-R

Set the color of the marking and check its area in the field of view. Narrow angle view version can zoom up small area.

14. Checking ON/OFF of LED on PWB



CVS2-R

Check the color and position of LED by its color pattern matching function

15. Checking order of the color of wires



CVS2-R

Check the color and position of wires by its color pattern matching function

16. Checking existence of bad marking on parts



CVS2-R

Check color of the parts and color of bad marking on the parts to detect existence of bad parts

17. Checking existence of wafer

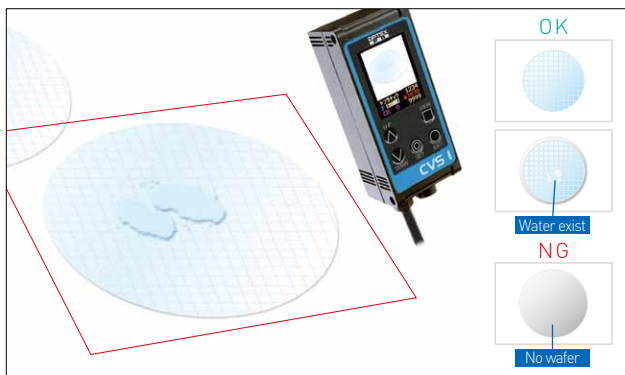

CVS1-R

Set the color of the wafer as its reference and detect existence of the wafer even there are some water on it

18. Checking direction of the parts



CVS3-R

Check the edge of the marking on the IC package and detect direction of it

19. Checking position of welded part



CVS2-R

Set the color of the pipe and welded part and detect welded part stably by its pattern matching function

20. Checking shape of assembled parts



CVS3-R

Check the shape of the assembled parts by edge detecting function utilizing back lighting

21. Checking direction of the parts on conveyor



CVS2-R

Check the color and position of the surface pattern by its color pattern matching function

22. Checking size of the nut



CVS3-R

Check size of the nut by edge detecting function

23. Checking characters on metal parts



CVS4-R

Check the characters engraved on the metal parts by its OCR function

24. Checking existence of lot number on the spark plugs



CVS1-R

Check the color area of the printed characters on the spark plugs

CVS1easy-R SERIES



Simple & Easy setup Color area sensor

- All in one color vision sensor
- Color resolution : 15,000 colors
- Stable color detection by calculating hue of each pixel



Wide range line-up

- CVS1easy-N20-R Standard type
- CVS1easy-N10-R Long range type
- CVS1easy-N40-R Macro view type
- CVS1easy-N21-R Narrow view type

All in one

The sensor has a built-in Camera, LED Lighting, Display monitor and Controller. This structure enables water resistance IP67.

Quick change over

8 Banks are available. You can remotely select the bank to use by PLC or other equipments.

Three-Step-Teaching

Teaching is easily done by three steps even in 30 seconds just like a color sensor.

Step1 Get into teaching mode



Step2 Set field of view



Chose the number to zoom in and zoom out

Step3 Set color



Chose the color from the list shown. You can also use teaching window on the view

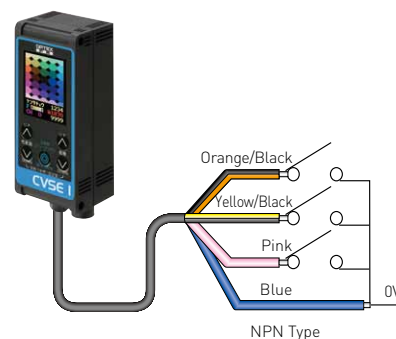
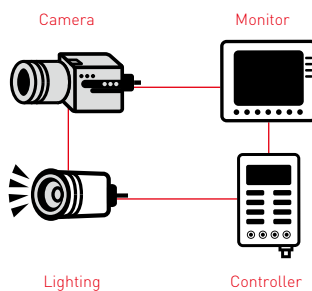

Easy Threshold adjustment

Changing sensitivity of color extraction and threshold of inspection is easily done by simple buttons.



Color Resolution

Up to 15,000 colors are available to detect.

Stable inspection

It calculates color hue of each pixel so stable inspection is available.

Wide coverage line-up

You can chose from 4 inspection range/field of view according to inspection target condition.

High performance

Setup Adjustable while line is running

CVS1easy-R provides output with the setup parameters given even while you are adjusting setup. You don't have to stop the line.



CVS1easy-R has two processing unit individually so it can change parameters while vision processing is running without delay.

Secret of High speed

Transferring captured data and vision processing are parallelly done utilizing internal memory. It helps to shorten response time.

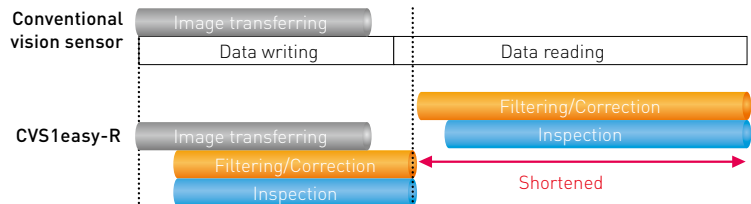

Stable inspection

It calculates color hue of each pixel that prevents miss-inspection affected by external light and brightness changes of lighting. Stable inspection is available and you can setup CVS1easy-R just like you do for photoelectric sensor.

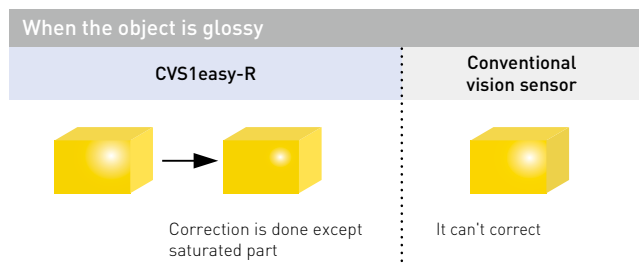
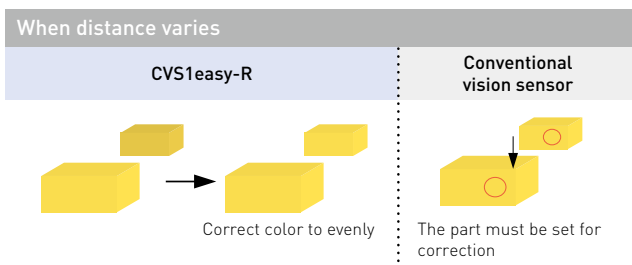
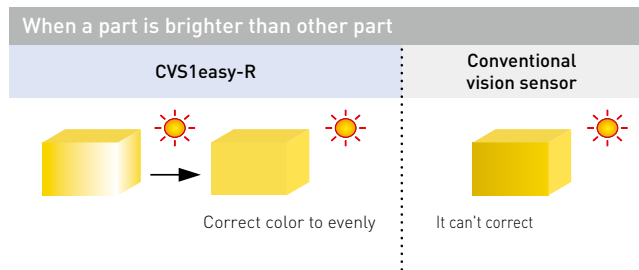
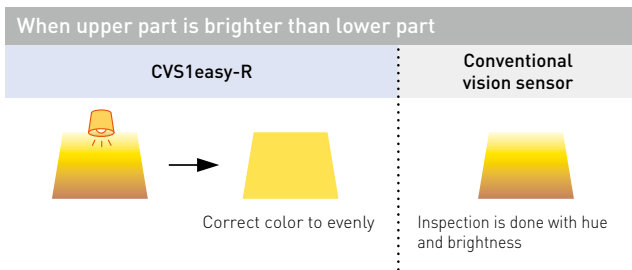

Display

There are two mode: Normal / Setup

Normal mode

- 1 Captured image**
Image captured by the camera
- 2 Bank No.**
Current Bank No.
- 3 Display mode**
F: Dark Compensated image
2: Shows black except chosen color area
- 4 Registered color**
Min. and Max. color
- 5 Range of color**
Shows range of color. You can adjust by Color Range buttons.
Default : 13
- 6 Output**
● : ON × : OFF
- 7 Color match area**
Shows area that color is in the threshold. Green: In threshold, Red: Out of threshold
- 8 Threshold**
Shows threshold

Switches

UP+1

Increase Color Range

UP+1

Increase Threshold

DOWN-1

Decrease Color Range

DOWN-1

Decrease Threshold

SET / VIEW

Teach-in by pressing 3 sec. or more. Chose and set the parameter in Setup mode

* Change the mode to Setup by pressing both "DOWN-1" buttons 3 sec. or more.

Specifications

Model	CVS1easy-N10-R CVS1easy-P10-R	CVS1easy-N20-R CVS1easy-P20-R	CVS1easy-N21-R CVS1easy-P21-R	CVS1easy-N40-R CVS1easy-P40-R
Detection angle	10°	20°		40°
Working distance	210 to 270mm	90 to 150mm	31 to 39mm	50 to 100mm
Field of view	40 x 50mm to 55 x 65mm	40 x 50mm to 65 x 75mm	17 x 20mm (±10%)	50 x 65mm to 100 x 115mm
Light source	White LED 12 pcs built-in			
Image sensor	330,000 Pixel CMOS color image sensor			
Supply Voltage	12 to 24V DC±10%			
Power consumption	Max. 120mA/24V DC			
Resolution	5 x 12 to 200 x 240			
LED light duration	Approx.50,000 hours (In normal temperature and humidity. Brightness level down by 1/2 of the initial level)			
Response time	11ms (Factory setting),5.0ms(min.),22ms(Max.)			
Output signal	NPN or PNP open collector output x 1 max.100mA Residual voltage 1.0V or less			
Input	3 x Bank selection,1 x Synchronous(Totally4)			
Operating temperature	0 to 40°C (No condensation)			
Operating humidity	35 to 85%RH			
Storage temperature/humidity	-20 to 70°C,35 to 95%RH (No condensation)			
Vibration/shock resistance	10 to 55Hz Amplitude 1.5mm/50G (500m/s ²)			
Material	Case:ABS/Display and Lens:Acryl or Polycarbonate			
Protection structure	IP67			
Weight	Approx.180g (including cable)			

Parameters

Function	Setting range (Default)	Description
LCD Disp.		
Brightness BRIGHT	0 to 255 (100)	Specifies the brightness of the screen (shutter time). The optimal value is set at teaching. The shutter time is calculated with "the setting value x 54.5 μs."
Initializing setting value INITIAL	NO, YES (NO)	Initializes all the set values by setting "YES."
Off delay OFF DLY	0 to 5000 (0)	Sets the Off delay time of output. When set to one shot (ONESHOT = ON), the value means period of oneshot output. (Unit: ms)
On delay ON DLY	0 to 5000 (0)	Sets the On delay time of output. (Unit: ms)
One shot ONESHOT	OFF, ON (OFF)	Switches to the oneshot output. The time is specified by the value of OFF DLY .
Output reverse OUTSIDE	LOW, HIGH (LOW)	Switches the relationship between the area and the output. LOW : The output turns on when the area is equal to area threshold or more than that. HIGH : The output turns on when the area is less than area threshold.
Resolution RESOLUT	LOW, HIGH (LOW)	Specifies the resolution of the image to be captured. LOW : Reduces the horizontal resolution and response time to half. Effective for fast moving object that doesn't need higher resolution. HIGH : Doesn't reduce the resolution.
Synchronous input SYNCHRO	OFF, ON (OFF)	OFF : Capture continuously. ON : Capture at the rising point of synchronous input (purple).

LCD Disp displayed in yellow: the setting item is common to all banks.
LCD Disp displayed in purple: the setting item switches to the specific value of each bank.



When switching banks changing resolution and zoom rate, the image sensor may take approx. 2 seconds to be stable. Set same resolution and zoom rate when change banks continuously.

Connection diagram

(NPN)

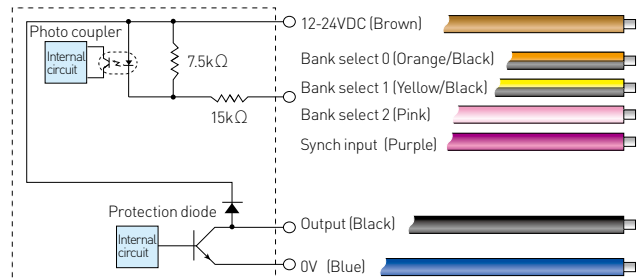

(PNP)

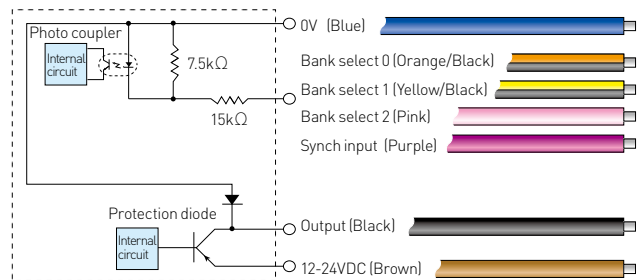

Bank table

Cable Color	Signal	Bank No.							
		0	1	2	3	4	5	6	7
Orange/Black	Bank selection 0 input	OFF	ON	OFF	ON	OFF	ON	OFF	ON
Yellow/Black	Bank selection 1 input	OFF	OFF	ON	ON	OFF	OFF	ON	ON
Pink	Bank selection 2 input	OFF	OFF	OFF	OFF	ON	ON	ON	ON

OFF	NPN: OPEN or connect with the brown line. PNP: OPEN or connect with the blue line.
ON	NPN: connect with the blue line. PNP: connect with the brown line.

Field of View

CVS1easy-N10-R Long range type

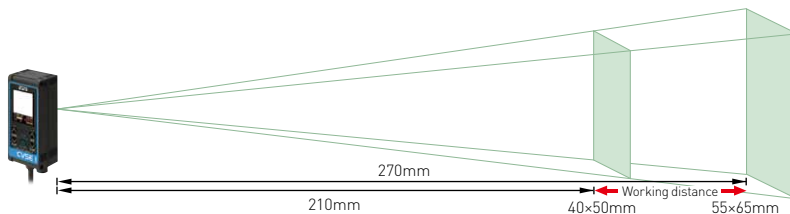

CVS1easy-N40-R Macro view type

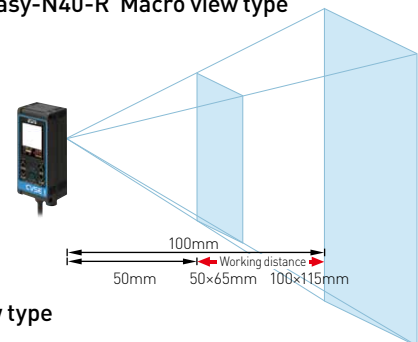

CVS1easy-N20-R Standard type

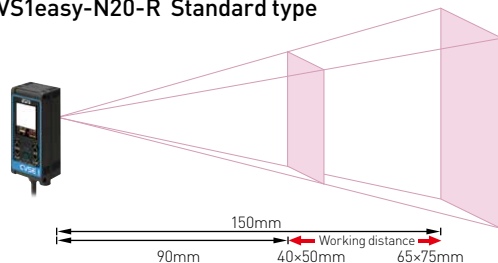

CVS1easy-N21-R Narrow view type

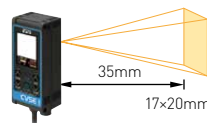



Easy setup Color sensor

- All in one color vision sensor
- High speed : 0.6 - 22ms
- Stable color detection by calculating hue of each pixel



Wide range line-up

- CVS1-N20-R Standard type
- CVS1-N10-R Long range type
- CVS1-N40-R Macro view type
- CVS1-N21-R Narrow view type

One threshold mode

Determine OK when the area that the color matches exceeds the threshold.

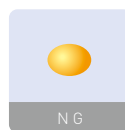
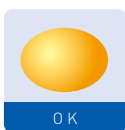

Two threshold mode

Determine OK when the area that the color matches is in two thresholds.

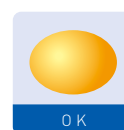
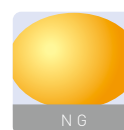

Easy Teaching

Teaching is easily done by moving the teaching cursor on the part that you want to teach the color and just set it.

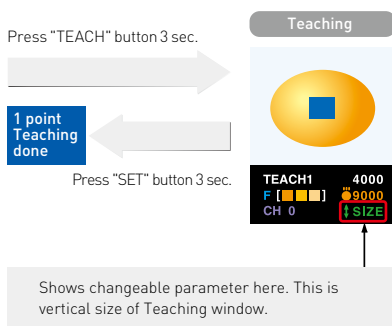

Setup per application

Set "INITIAL" proper number as following table shows. Parameters will be set automatically for the application.

	print	print on glossy surface	fine color difference	glossy surface	black and white		fine dark color difference	print on rough surface
Application	Shelf life 2005.8.25	2005.8.25						Shelf life 2005.8.25
INITIAL	1	2	3	4	5	6	7	8

High Speed : 0.6 - 22ms

Newly developed vision processor enables high speed inspection.

Up to 16 Bank

16 Banks are available in small all in one package.

Zoom function

You can zoom in a part of the object. You can inspect 16 parts of the object changing Bank efficiently.

Stable inspection

It calculates color hue of each pixel that prevent miss-inspection.

Wide coverage line-up

You can chose from 4 inspection range/field of view according to inspection target condition.

High performance

Setup Adjustable while line is running

CVS1-R provides output with the setup parameters given even while you are adjusting setup. You don't have to stop the line.



Lower Limit output

You can see which the NG output is lower than lower threshold or higher than upper threshold.

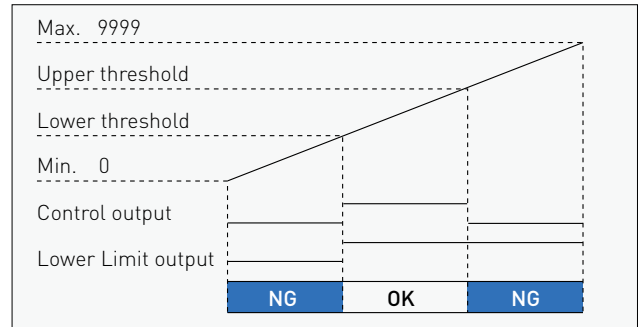

Secret of High speed

Transferring captured data and vision processing are parallelly done utilizing internal memory. It helps to shorten response time.

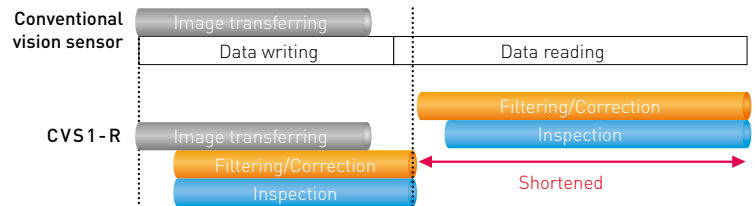

Stable inspection

It calculates color hue of each pixel that prevent miss-inspection affected by external light and brightness changes of lighting. Stable inspection is available and you can setup CVS1-R just like you do for photoelectric sensor.

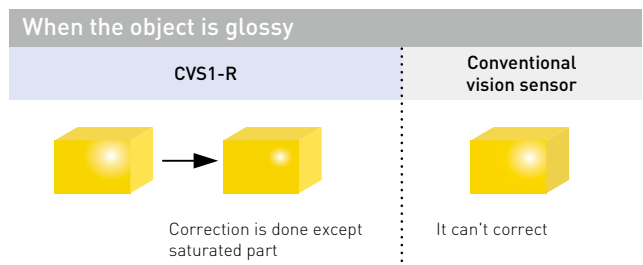
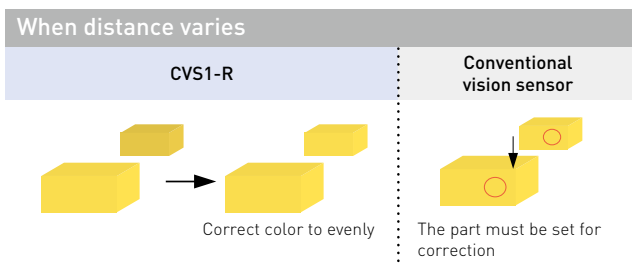
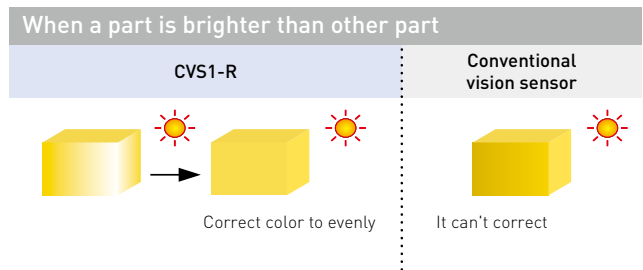
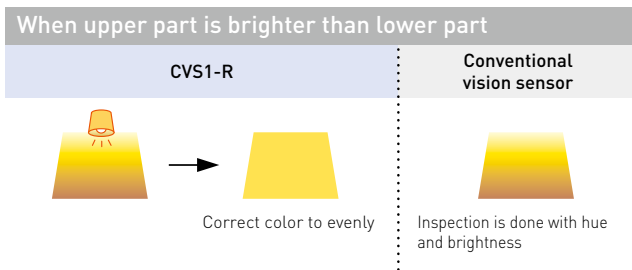

Display

There are two mode: Normal / Setup

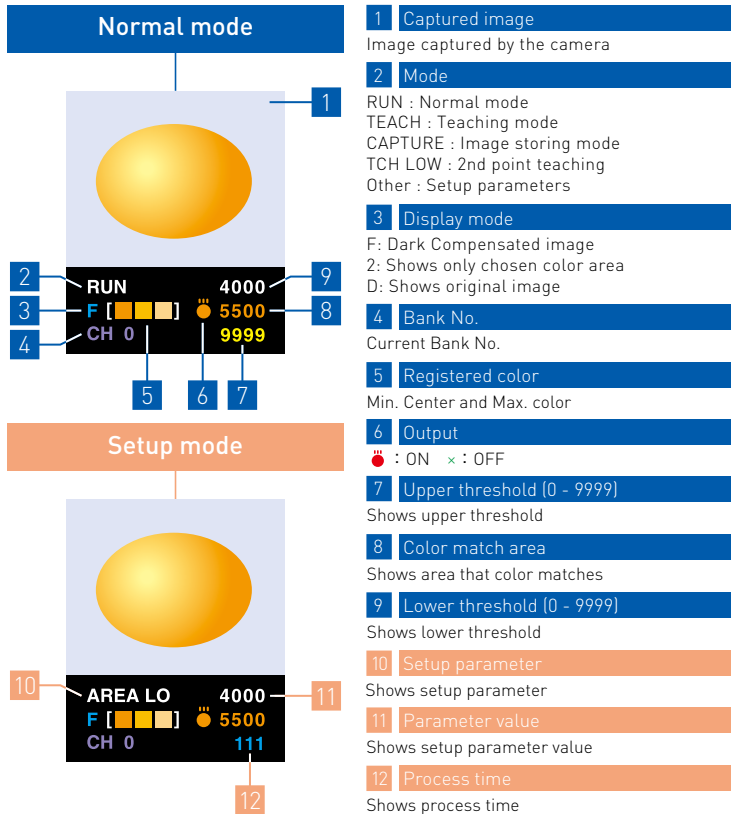

Switches



Specifications

Model	CVS1-N10-R CVS1-P10-R	CVS1-N20-R CVS1-P20-R	CVS1-N21-R CVS1-P21-R	CVS1-N40-R CVS1-P40-R
Detection angle	10°	20°		40°
Working distance	210 to 270mm	90 to 150mm	31 to 39mm	50 to 100mm
Field of view	40 x 50mm to 55 x 65mm	40 x 50mm to 65 x 75mm	17 x 20mm (±10%)	50 x 65mm to 100 x 115mm
Light source	White LED 12 pcs built-in			
Image sensor	330,000 Pixel CMOS color image sensor			
Supply Voltage	12 to 24V DC±10%			
Power consumption	Max. 120mA / 24V DC			
Resolution	8 x 16 to 200 x 240			
LED light duration	Approx.50,000 hours (In normal temperature and humidity. Brightness level down by 1/2 of the initial level)			
Response time	0.6ms to 22ms			
Output signal	NPN or PNP open collector output x 2 [one of them is "Lower limit output"selectable with bank input #1] max.100mA Residual voltage 1.0V or less			
Input	4 x Bank selection / 1 x Synchronous / 1 x External teaching / 1 x Lower limit output (Totally 4)			
Operating temperature	0 to 40°C (No condensation)			
Operating humidity	35 to 85%RH			
Storage temperature/humidity	-20 to 70°C,35 to 95%RH (No condensation)			
Vibration/shock resistance	10 to 55Hz Amplitude 1.5mm / 50G (500m/s ²)			
Material	Case:ABS / Display and Lens:Acryl or Polycarbonate			
Protection structure	IP67			
Weight	Approx.180g (including cable)			

Connection diagram (NPN)

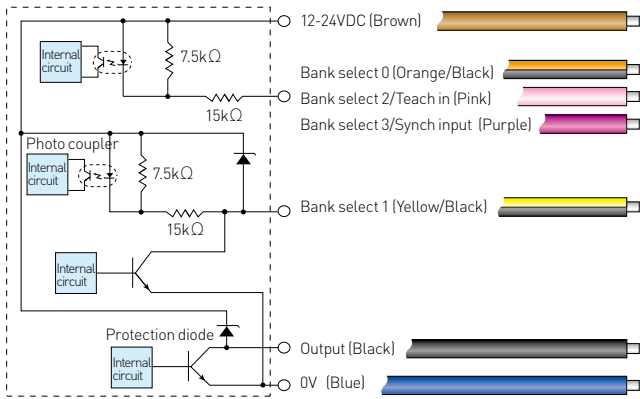

Bank table

Bank No.	Bank select input			
	3(Purple)	2(Pink)	1(Yellow/Black)	0(Orange/Black)
0	OFF	OFF	OFF	OFF
1	OFF	OFF	OFF	ON
2	OFF	OFF	ON	OFF
3	OFF	OFF	ON	ON
4	OFF	ON	OFF	OFF
5	OFF	ON	OFF	ON
6	OFF	ON	ON	OFF
7	OFF	ON	ON	ON

Field of View

CVS1-N10-R Long range type

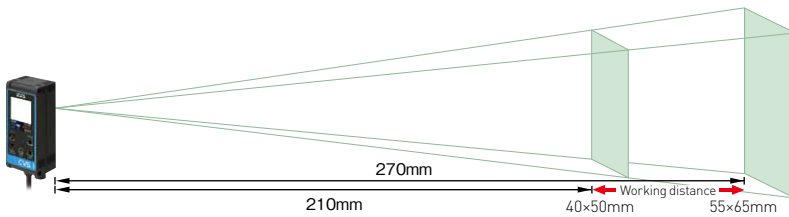

CVS1-N40-R Macro view type

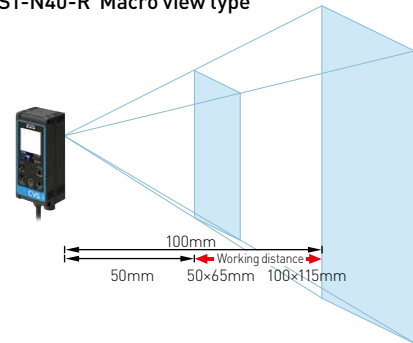

CVS1-N20-R Standard type

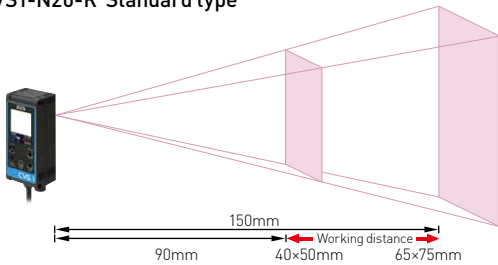

CVS1-N21-R Narrow view type

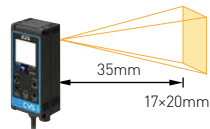

CVS2-R SERIES



Detect Color and Shape for various inspection

- All in one color vision sensor
- For Pattern matching and Color inspection
- Better sensitivity by Masking function



Wide range line-up

- CVS2-N20-R Standard type
- CVS2-N10-R Long range type
- CVS2-N40-R Macro view type
- CVS2-N21-R Narrow view type

Pattern matching mode and Color inspection mode are available

Inspection of shape and direction of the object is available by pattern matching mode. You can use CVS2-R as simple Color inspection sensor as well. Sorting by color is also available.

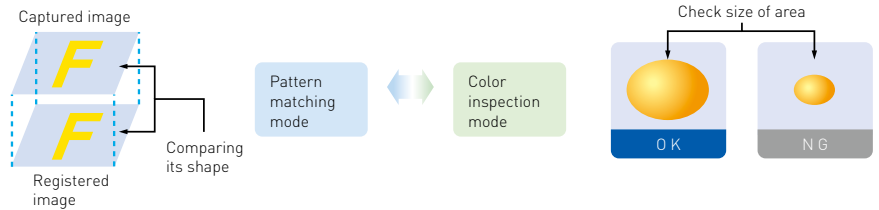

Correct background brightness

CVS2-R has a function that corrects evenness of background brightness. You register just the background for reference.



Masking function

You can mask the area that doesn't have to be checked so that you can get better sensitivity of color inspection.

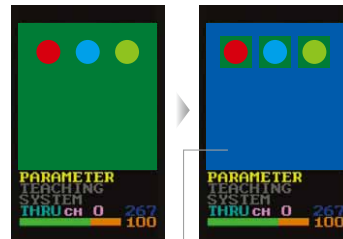

Masking area

Downloading setup parameters to PC

You can download setup data and image data into PC. You can use the image data on PC and can copy setup to other CVS2-R. Please use I/F cable CVS-C2C.

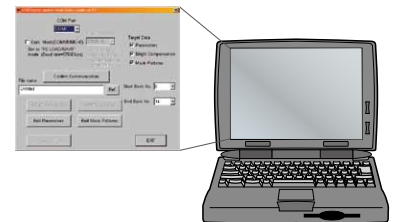

Zoom function

CVS2-R has Zoom function so you can zoom in up to twice size.

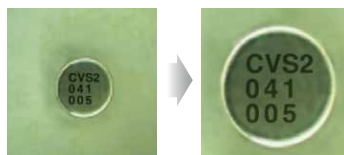

x2

Up to 15 Bank

15 Banks are available in small all in one package.

Wide coverage line-up

You can chose from 4 inspection range/field of view according to inspection target condition.

Pattern Matching mode

CVS2-R detects up to 65,536 colors and checks its shape to compare with registered image.

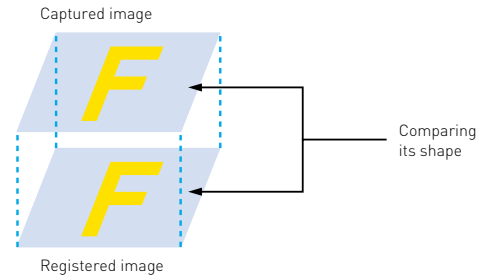

Color Inspection mode

Determine OK when the area that the color matches exceeds the threshold.

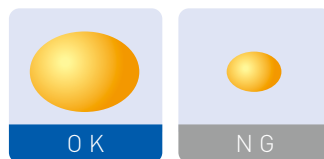

Determine OK when the area that the color matches is in two thresholds.

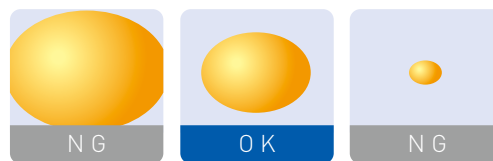

Two Color Inspection at a time

CVS2-R can inspect two colors for one application at a time.

Checking Two Color

You can set Upper and Lower threshold for two colors to inspect. You can chose a logic from 4 combination.



Two bar graphs for two colors

Two threshold for two colors each

Masking function

You can mask the area you don't want to detect the color freely in position.

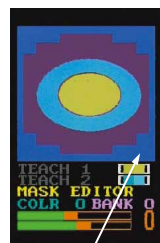

Blue part is masked area

Sorting function

Sorting is available by utilizing two outputs up to 3. You can also increase the sorting number up to 15 by utilizing RS-232C controlling or external unit TMC-N11-CVS.



When this parameter is 1, you can sort in two criteria.

Features

Secret of High speed

Transferring captured data and vision processing are parallelly done utilizing internal memory. It helps to shorten response time.

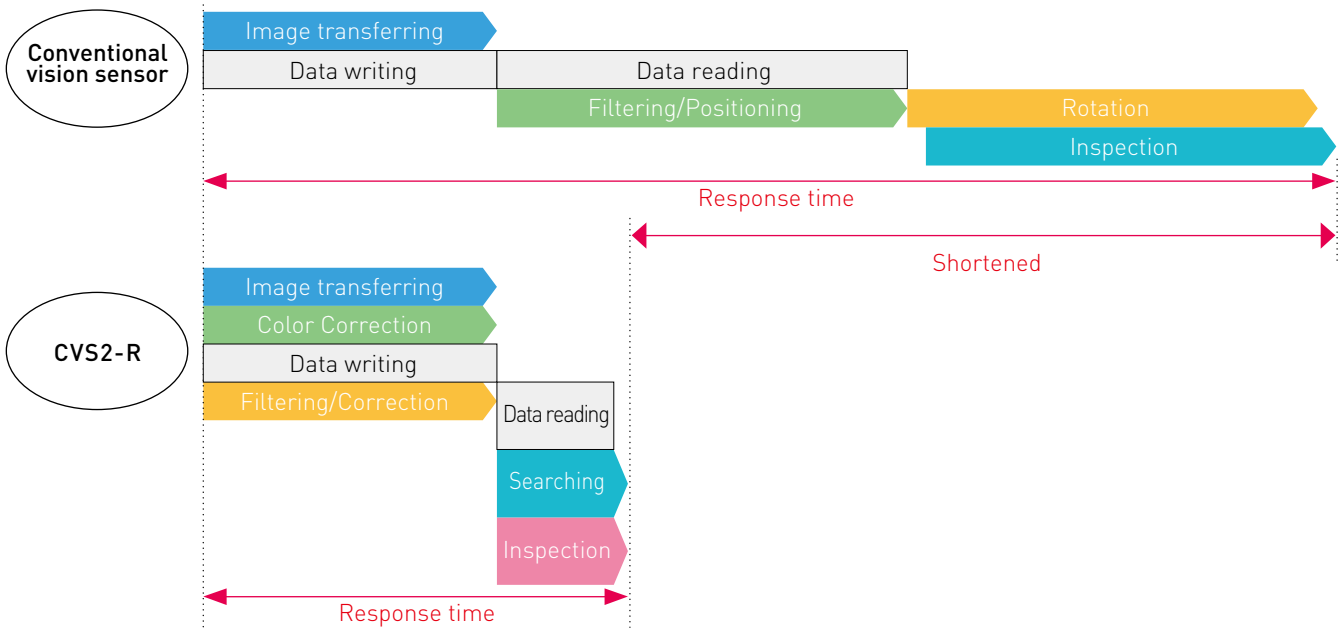

Setup Adjustable while line is running

CVS2-R provides output with the setup parameters given even while you are adjusting setup. You don't have to stop the line.

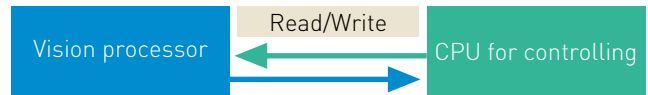
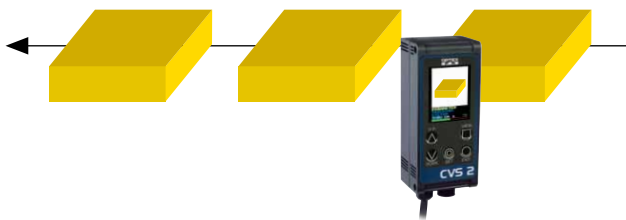

CVS2-R has two processing unit individually so it can change parameters while vision processing is running without delay.

Correct background brightness

CVS2-R has a function that corrects evenness of background brightness. You register just the background for reference.

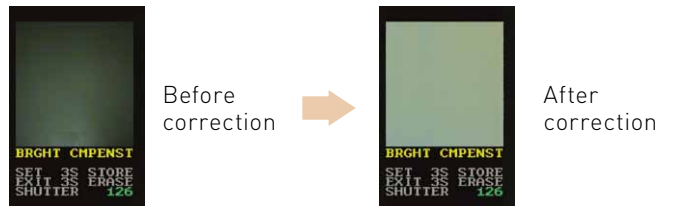

Masking

You can mask the area that doesn't have to be checked so that you can get better sensitivity of color inspection.

Setup You can setup the area to mask as follows.

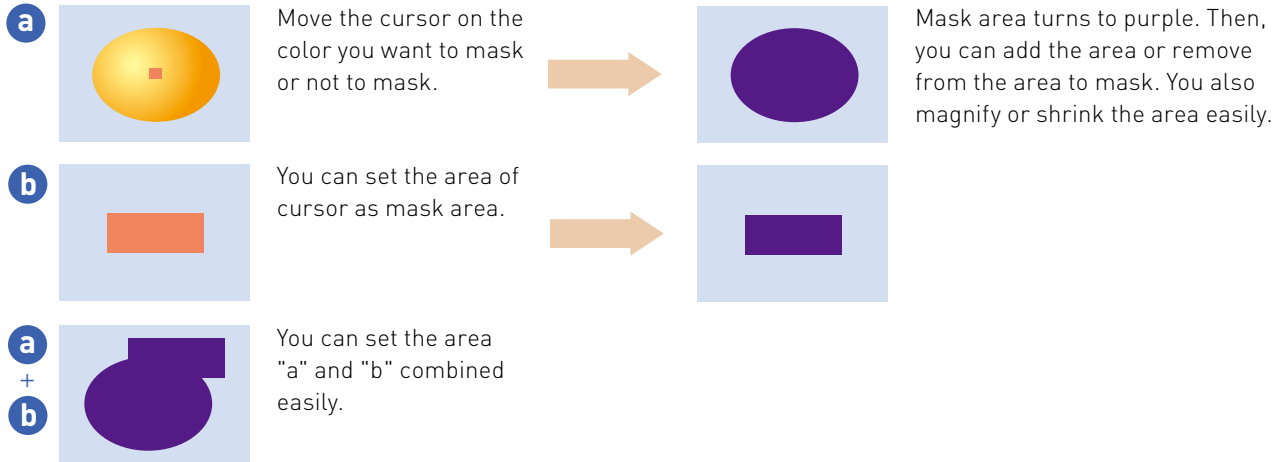

Color inspect area

You can limit the area to inspect color from. This prevents miss-detection of color at the edge of the FOV.

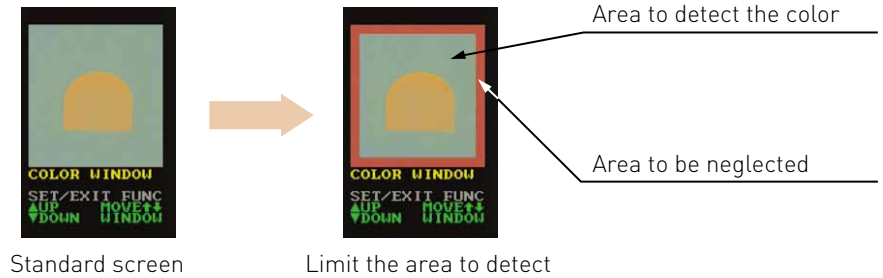

Example of masking

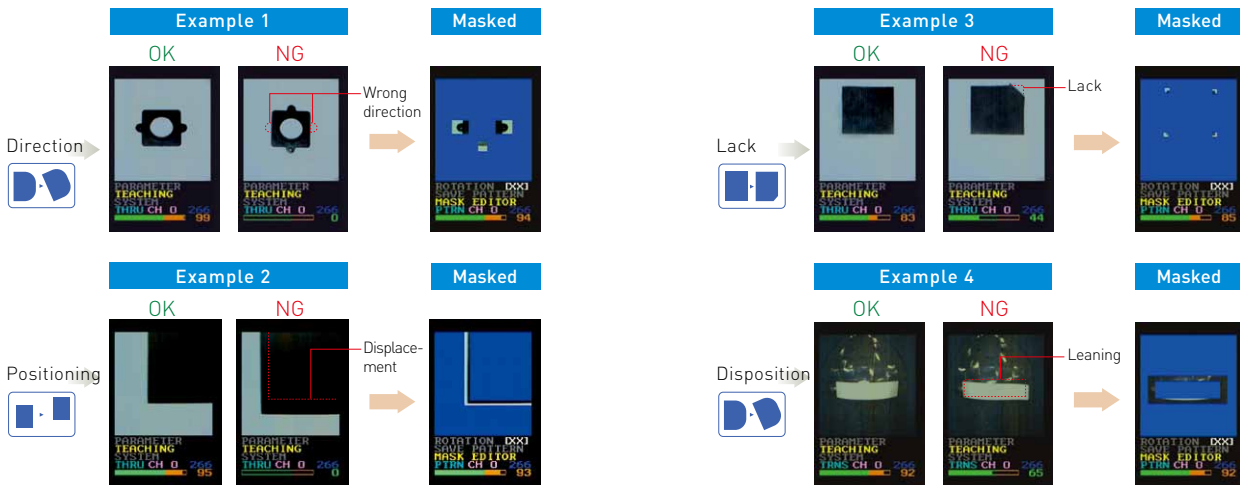

You can get better result by masking the area that doesn't show characteristics of the target object.

Display

Pattern matching mode

- Captured image
Image captured by the camera
- Parameters
Shows parameters
- Display mode
You can change display mode by VIEW button
- Bar graph
Shows how big the area that the color matches. Threshold is at the border of green and orange.
- Bank No.
Shows current Bank.
- Auxiliary output
Status of auxiliary output.
● : means ON
- Color match area
Shows area that color matches.
Orange : ON, Green : OFF
- Response time
Shows response time. Unit : 0.1ms.
Example : 266 = 26.6ms

CVS1 compatible mode

- Captured image
Image captured by the camera
- Parameters
Shows parameters
- Display mode
Shows display mode
- Display mode
Shows how big the area that the color matches.
- Registered color
Min. Center and Max. color
- Bank No.
Shows current Bank.
- Output/Sorting status
Orange: ON, Green: OFF
Shows sorting No. when it's active.
- Monitoring Bank No.
Shows Bank No. for sorting.

When sorting is active

Switches

- UP**: Move cursor up and increase parameter value
- DOWN**: Move cursor down and decrease parameter value
- VIEW**: Change the display mode
F: Dark Compensated image
2: Shows only chosen color area
D: Shows original image
- EXIT**: Use this button when you quit changing parameter and going back to previous menu.
- SET**: Change to setup mode.
Chose the parameter by pressing 3 sec. or more.

Specifications

Model	CVS2-N10-R CVS2-P10-R	CVS2-N20-R CVS2-P20-R	CVS2-N21-R CVS2-P21-R	CVS2-N40-R CVS2-P40-R
Detection angle	10°	20°		40°
Working distance	210 to 270mm	90 to 150mm	31 to 39mm	50 to 100mm
Field of view	40 x 50mm to 55 x 65mm	40 x 50mm to 65 x 75mm	17 x 20mm (±10%)	50 x 65mm to 100 x 115mm
Light source	White LED 12 pcs built-in			
Image sensor	330,000 Pixel CMOS color image sensor			
Supply Voltage	12 to 24V DC±10%			
Power consumption	Max. 140mA/24V DC			
Resolution	8 x16 to 200 x 240			
LED light duration	Approx.50,000 hours(In normal temperature and humidity. Brightness level down by 1/3 of the initial level)			
Response time	4ms to 22ms			
Output signal	NPN or PNP open collector output x 2 max. 100mA Residual voltage 1.0V or less			
Input	4 x Bank selection / 1 x Synchronous / 1 x External teaching (Totally 4)			
Operating temperature	0 to 40°C (No condensation)			
Operating humidity	35 to 85%RH			
Storage temperature/humidity	-20 to 70°C, 35 to 95%RH(No condensation)			
Vibration/shock resistance	10 to 55Hz Amplitude 1.5mm / 50G(500m/s ²)			
Material	Case:ABS / Display and Lens : Acryl or Polycarbonate			
Protection structure	IP67			
Weight	Approx.180g (including cable)			

Connection diagram

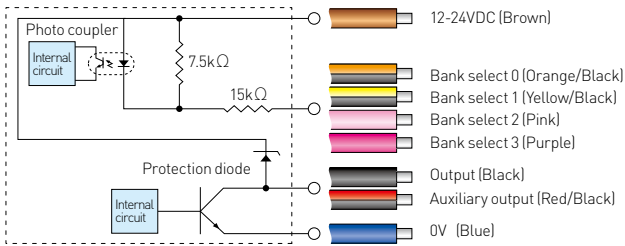

Auxiliary output

AUX OUT=0: Ready - Turns OFF after switching Bank.
 Turns ON when Output is ready

AUX OUT=1: Judge timing - Turns ON when Judge timing

AUX OUT=2: Light timing - Turns ON when Lighting

AUX OUT=3: Searching result - Turns ON when each search result is in its criteria, MAGNIFY%, POSIT% X, POSIT% Y, ROTATE%.

Bank table

Set up	BANK	0-14		15		16		
	SYNCHRON	4	0-3	4	0-3	4	0-3	
External Input	Bank select 0	NA		Active				
	Bank select 1	NA		Active				
	Bank select 2	External Teach-in						Active
	Bank select 3	NA	Synch.In	Active	Synch.In	Active	Synch.In	

Bank No.	Bank select input			
	3(Purple)	2(Pink)	1(Yellow/Black)	0(Orange/Black)
0	OFF	OFF	OFF	OFF
1	OFF	OFF	OFF	ON
2	OFF	OFF	ON	OFF
3	OFF	OFF	ON	ON
4	OFF	ON	OFF	OFF
5	OFF	ON	OFF	ON
6	OFF	ON	ON	OFF
7	OFF	ON	ON	ON
8	ON	OFF	OFF	OFF
9	ON	OFF	OFF	ON
10	ON	OFF	ON	OFF
11	ON	OFF	ON	ON
12	ON	ON	OFF	OFF
13	ON	ON	OFF	ON
14	ON	ON	ON	OFF
0	ON	ON	ON	ON

Sorting output

You can get sorting output from following table that shows which bank matches by combination of Output (Black) and Auxiliary output (Red/Black) signals.

Bank No.	Output(Black)	Auxiliary output(Red/Black)
Current Bank	ON	OFF
+1	OFF	ON
+2	ON	ON

OFF	NPN: OPEN or connect with the brown line. PNP: OPEN or connect with the blue line.
ON	NPN: connect with the blue line. PNP: connect with the brown line.

Field of View

CVS2-N10-R Long range type

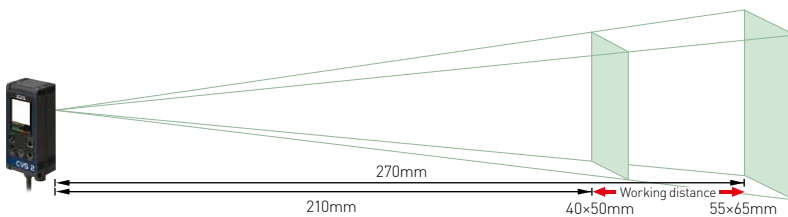

CVS2-N40-R Macro view type

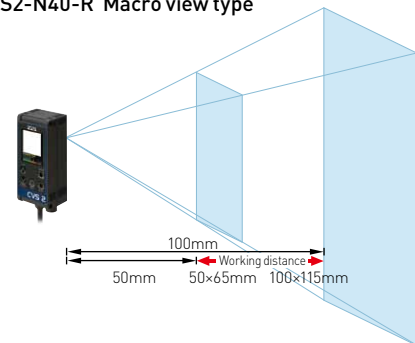

CVS2-N20-R Standard type

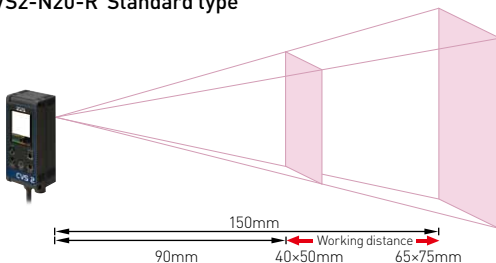

CVS2-N21-R Narrow view type

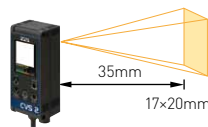



Edge sensor for various applications

- All in one color vision sensor
- Easy setup and High performance
- Useful Zoom-in function



Wide range line-up

- CVS3-N20-R Standard type
- CVS3-N10-R Long range type
- CVS3-N21-R Narrow view type

New inspection mode: Contour mode, Differential mode

New inspection mode, Contour mode and Differential mode have been added up on conventional CVS3-R compatible mode. It has improved search function and improved color/contrast correct function.

Masking function

You can mask the area that doesn't have to be checked so that you can get better sensitivity of inspection.



	Compatible mode	Contour mode	Differential mode
Mode			
Application	<p>Metal parts</p>	<p>Metal parts</p> <p>Contour mode+Monochrome mode</p> <p>For flaw with slight color difference</p> <p>Contour mode+Color inspection</p> <p>For slight color difference and shape</p> <p>Contour mode+inspection of entire area</p>	<p>Checking picture</p> <p>Differential mode</p> <p>For low contrast object</p> <p>Differential mode+Color inspection</p>

Zoom function

CVS3-R has Zoom function so you can zoom in up to twice size.

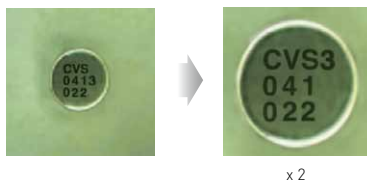

Downloading setup parameters to PC

You can download setup data and reference image data into PC. You can copy the reference image data and the setup data to other CVS3-R. Please use I/F cable CVS-C2C.

Up to 15 Bank

15 Banks are available in small all in one package.

Other FOV type is available

In case you need other FOV type like CVS1-R or CVS2-R, please contact our distributor.

Features

7 binarize level

When it compares binarized image between registered image and captured image, it chooses best binarize level to get best image automatically. This is effective when the lighting is not stable.

Existence of graved mark on metal or glass

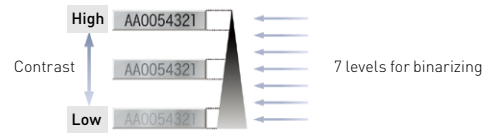

Scaling up/down

Correcting size function correct captured image size. This function is effective for inspection of the object on conveyor.

Detecting direction of object



Size of image captured is changed in case the conveyor waves or its speed changes. In this case, this function automatically changes image size when it searches target image.



Rotate correction

Correction of rotation is available up to +/- 6.2degree.

Inspection of chocolate shape



Find out best angle rotating the captured image step by step



Detecting Color edge

Detect edge between different colors and get clear image to inspect.

Inspection of colored label direction



You can detect even red color on green background easily that monochrome camera can't.



Easy Teaching

You can externally teach CVS3-R just by inputting single Teaching signal. Then, CVS3-R updates its image for reference automatically.

Verifying shelf life that changes everyday



Display

Compatible mode



- 1 Captured image
Image captured by the camera
- 2 Parameters
Shows parameters
- 3 Lack/Stain pixels
Shows lack of edge and stain on the background
- 4 Stableness of threshold level
↑: Increase THRESHLD
↓: Decrease THRESHLD
- 5 Display mode
Shows current display mode
- 6 Judge result
Shows judge result
- 7 Bank No./Response time
Shows Bank No. in normal mode. Shows response time while setup mode

Contour mode

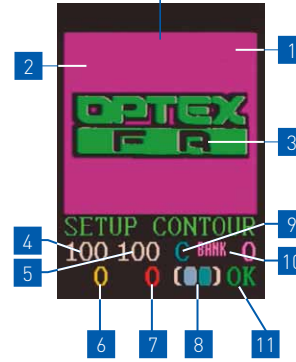

- 1 Area to detect stain
It shows pixel in red when it matches to the contour and Stain pixel No. will be increased
- 2 Area to detect lack of contour
It shows pixel in yellow when it's detected as lack of contour and Lack pixel No. will be increased
- 3 Area to neglect
It doesn't affect anything even if there is contour in this area
- 4 Threshold of lack of contour
- 5 Threshold of stain
- 6 Lack pixel No.
- 7 Stain pixel No.
- 8 Registered color (bright / dark)
- 9 Display mode
- 10 Bank No.
- 11 Judge result

Differential mode

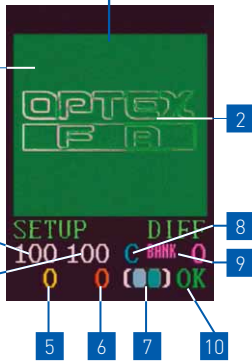

- 1 Area without contour
It shows pixel in yellow or red when it detect contour and differential rate will be increased
- 2 Area with contour should exist
It shows pixel in yellow or red when it doesn't detect contour and differential rate will be increased
- 3 Threshold of differential rate
- 4 Threshold of color area rate
- 5 Differential rate
- 6 Color area rate
- 7 Registered color (bright / dark)
- 8 Display mode
- 9 Bank No.
- 10 Judge result

Switches

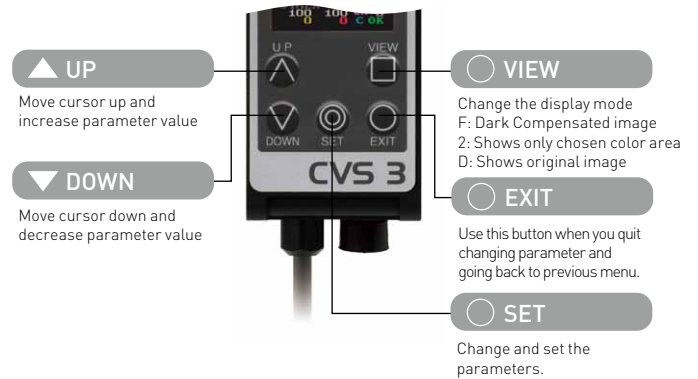

Specifications

Model	CVS3-N10-R CVS3-P10-R	CVS3-N20-R CVS3-P20-R	CVS3-N21-R CVS3-P21-R
Detection angle	10°	20°	
Working distance	210 to 270mm	90 to 150mm	31 to 39mm
Field of view	40 x 50mm to 55 x 65mm	40 x 50mm to 65 x 75mm	17 x 20mm (±10%)
Light source	White LED 12 pcs built-in		
Image sensor	330,000 Pixel CMOS color image sensor		
Supply Voltage	12 to 24V DC±10%		
Power consumption	Max. 140mA/24V DC		
Resolution	16 x16 to 208 x 236		
LED light duration	Approx.50,000 hours(In normal temperature and humidity. Brightness level down by 1/3 of the initial level)		
Response time	48ms (Factory setting).2.5ms (Min). 518ms (Max)		
Output signal	NPN or PNP open collector output x 2 max. 100mA Residual voltage 1.0V or less		
Input	4 x Bank selection / 1 x Synchronous / 1 x External teaching (Totally 4)		
Operating temperature	0 to 40°C (No condensation)		
Operating humidity	35 to 85%RH		
Storage temperature/humidity	-20 to 70°C, 35 to 95%RH (No condensation)		
Vibration/shock resistance	10 to 55Hz Amplitude 1.5mm / 50G (500m/s ²)		
Material	Case:ABS / Display and Lens : Acryl or Polycarbonate		
Protection structure	IP67		
Weight	Approx.180g (including cable)		

Connection diagram

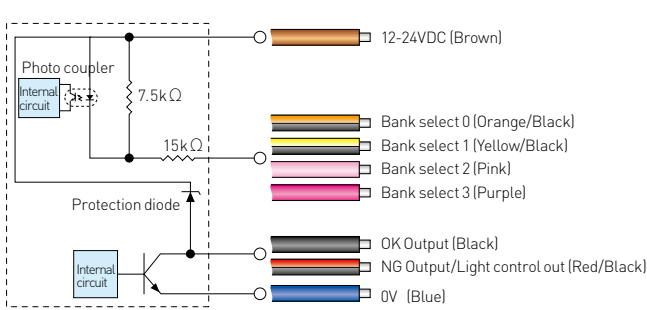

Bank table

Set up	BANK	0-14		15		16	
	SYNCHRON	4	0-3	4	0-3	4	0-3
External Input	Bank select 0	NA		Active			
	Bank select 1	NA		Active			
	Bank select 2	External Teach-in				Active	
	Bank select 3	NA	Synch.In	Active	Synch.In	Active	Synch.In

Bank No.	Bank select input			
	3(Purple)	2(Pink)	1(Yellow/Black)	0(Orange/Black)
0	OFF	OFF	OFF	OFF
1	OFF	OFF	OFF	ON
2	OFF	OFF	ON	OFF
3	OFF	OFF	ON	ON
4	OFF	ON	OFF	OFF
5	OFF	ON	OFF	ON
6	OFF	ON	ON	OFF
7	OFF	ON	ON	ON
8	ON	OFF	OFF	OFF
9	ON	OFF	OFF	ON
10	ON	OFF	ON	OFF
11	ON	OFF	ON	ON
12	ON	ON	OFF	OFF
13	ON	ON	OFF	ON
14	ON	ON	ON	OFF
0	ON	ON	ON	ON

OFF	NPN: OPEN or connect with the brown line . PNP: OPEN or connect with the blue line .
ON	NPN: connect with the blue line . PNP: connect with the brown line .

Field of View

CVS3-N10-R Long range type

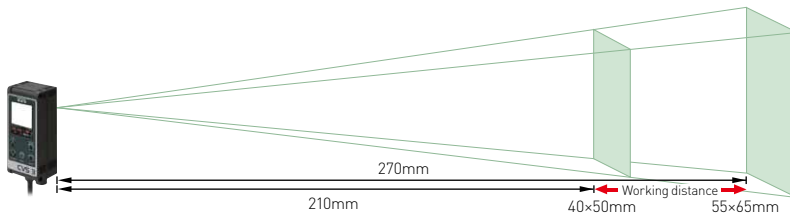

CVS3-N20-R Standard type

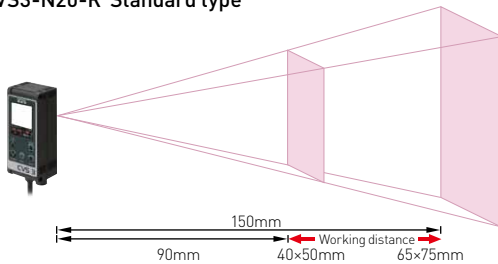

CVS3-N21-R Narrow view type

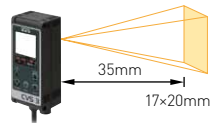



Compact OCR sensor

- All in one OCR sensor
- Easy setup and High performance
- Built-in Calendar

10.04.18
OPTEX FA



Wide range line-up

- CVS4-N23-R Standard type
- CVS4-N21-R Small character type
- CVS4-N20-R Long range type
- CVS4-N40-R Macro view type
- CVS4-N23R-R Standard vertical type

Easy setup

You can setup easily just following the instruction on the screen.

User dictionary

You can make characters utilizing the images captured and transferred to PC.

Up to 16 Bank

16 Banks are available in small all in one package.

Built-in Calendar

It can check the date continuously overnight referring built-in calendar without error because of its tolerance of time.

All in one OCR sensor

Recognizes Alphabetic, Numeric and Special characters. It can check shelf life, date of manufacture and lot number. It recognizes characters of Thermal printer, Hot printer, Ink-jet printer and Laser marker.



It compares the characters with internal Dictionary. You can setup as it determines NG when single character is wrong. You can also setup as it determines OK when the character has only small lack.

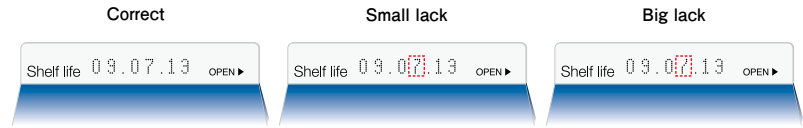

Storing NG image

When judge result changed from OK to NG, it stores NG image into internal memory up to 30 images. You can download the image data from CVS4-R through optional cable CVS-C2C.

Wide range of line-up

You can chose a range from 4 ranges of line-up.

CVS4-N23W-R/
-N23RW-R

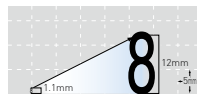

CVS4-N21W-R

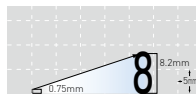

CVS4-N20W-R

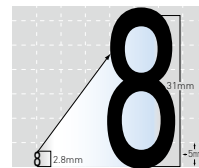

CVS4-N40W-R

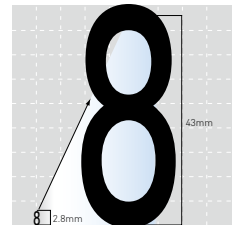

Character direction

CVS4-N23W-R/-N21W-R/
-N20W-R/-N40W-R



A 05 10 17
B 05 10 22

CVS4-N23RW-R



A 05 10 17
B 05 10 22

Features

Rotation search



It can search the characters rotating up to +/-19 degree.

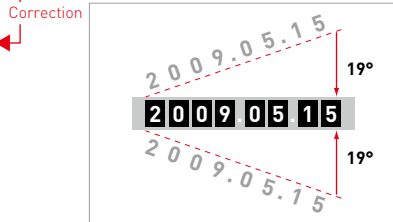

Recognize connected characters



Connected characters can be separated by adjusting the character width.

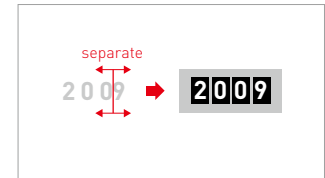

Double shutter



It captures twice by single trigger. If first image or 2nd image is OK, judge result is OK. This function is effective when the trigger timing is not stable and object position is not stable.

Continuous capture

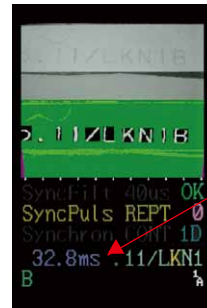

It will automatically capture and check the image continuously from single trigger until it gets OK image. If it gets Time-out before getting OK, it outputs NG.

Expandable FOV



You can expand vertical FOV when the character lines can't be in standard FOV



FOV can be vertically doubled by this function and it can detect the character lines in a FOV.

Mirror capture

It can capture mirror reversed image

Fast capture mode

It has Fast capture mode reducing vertical resolution down to half. This is effective for the objects that move fast.

Delayed Output function

It has timer to delay activating output for the period. This function can be utilized for controlling sorting stage located after the inspection stage.

Check character number

It can just check number of characters to see existence of the printing for example.

Delayed NG mode

It can turn output to NG only when it detect NG certain times continuously. This is effective for detecting ink runs out and some special error that happens rarely.

Wild card for verifying characters

You can use "?" as a wild card to determine a character as OK whatever the character is. This function is effective when the character can be any characters.

Display

Normal mode

- 1 Captured image
You can change by VIEW button. When it's detached mode, background is Green for OK and Red for NG.
- 2 Scale
Scale for adjust character size in FOV
- 3 Display mode
Shows display mode in yellow
- 4 Judge result
OK : Data/Time is in threshold and string matches
NG : Any lines doesn't match
ER : Backup error of calendar timer
- 5 Current Bank No.
- 6 Inspection item on screen
1D : The 1st date 2D : The 2nd date
1T : The 1st time 2T : The 2nd time
CH : Number of characters and character string
- 7 Response time from Synch. input to Judge output
- 8 Recognized Date/Time
- 9 Upper limit of Date/Time
- 10 Lower limit of Date/Time

Switches

- UP**: Move cursor up and increase parameter value
- DOWN**: Move cursor down and decrease parameter value
- VIEW**: Change the display mode. Press with "UP" and "DOWN" when you change the item to monitor.
- EXIT**: Change the mode from/to Normal mode to/from Teaching mode.
- SET**: Change the mode. Chose and set the parameters.
- DOWN + SET**: Set Lock mode, inhibit Teaching and changing parameters of setup. Press both buttons → 3sec.
- UP + SET**: Releases Lock mode.

Specifications

Model	CVS4-N20W-R CVS4-P20W-R	CVS4-N21W-R CVS4-P21W-R	CVS4-N40W-R CVS4-P40W-R	CVS4-N23W-R CVS4-P23W-R	CVS4-N23RW-R CVS4-P23RW-R
Detection angle	20°		40°	20°	
Working distance	90 to 150mm	31 to 39mm	50 to 100mm	44 to 56mm	44 to 56mm
Field of view	53x25mm to 79x38mm	21x10mm (±10%)	53x25mm to 115x53mm	30x15mm (±10%)	30x15mm (±10%)
Light source	White LED 12 pcs built-in				
Image sensor	330,000 Pixel CMOS monochrome image sensor				
Supply Voltage	12 to 24V DC±10%				
Power consumption	Max. 140mA / 24V DC				
Resolution	512 x 244				244 x 512
LED light duration	Approx.100,000 hours(In normal temperature and humidity. Brightness level down by 1/2 of the initial level)				
Response time	23ms to 48ms (20 characters in 2 lines,Rotation search up to ±10°)				
Output signal	NPN or PNP open collector output x 2 (OK/NGoutput,External light control output) max. 100mA Residual voltage 1.0V or less				
Input	4 x Bank selection / 1 x Synchronous / 1 x External teaching (Totally 4)				
Operating temperature	0 to 40°C (No condensation)				
Operating humidity	35 to 85%RH				
Storage temperature/humidity	-20 to 70°C, 35 to 95%RH(No condensation)				
Vibration/shock resistance	10 to 55Hz Amplitude 1.5mm / 50G(500m/s ²)				
Material	Case:ABS / Display and Lens : Acryl or Polycarbonate				
Protection structure	IP67				
Weight	Approx.200g (including cable)				
Recognizable character number	60 characters / 6 lines				
Character number per line	30 characters				
Number of date/time/string	Up to 2 x Date / 2 x Time / 4 x Strings with 22 characters (up to 4 items)				
User Dictionary	56 characters				
Built-in Timer accuracy	-45 sec. to 75 sec. per month				
Back up period of built-in timer	5 years by built-in non-rechargeable battery / Life of super capacitor : 7.8 years (when its capacity gets down to the level that keep timer 3 days)				

Connection diagram

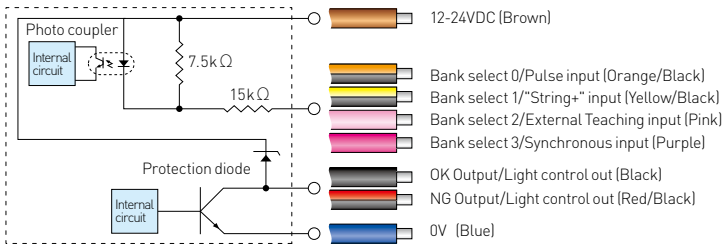

Bank table

Bank No.	Bank select input			
	3(Purple)	2(Pink)	1(Yellow/Black)	0(Orange/Black)
0	OFF	OFF	OFF	OFF
1	OFF	OFF	OFF	ON
2	OFF	OFF	ON	OFF
3	OFF	OFF	ON	ON
4	OFF	ON	OFF	OFF
5	OFF	ON	OFF	ON
6	OFF	ON	ON	OFF
7	OFF	ON	ON	ON
8	ON	OFF	OFF	OFF
9	ON	OFF	OFF	ON
10	ON	OFF	ON	OFF
11	ON	OFF	ON	ON
12	ON	ON	OFF	OFF
13	ON	ON	OFF	ON
14	ON	ON	ON	OFF
15	ON	ON	ON	ON

OFF	NPN: OPEN or connect with the brown line. PNP: OPEN or connect with the blue line.
ON	NPN: connect with the blue line. PNP: connect with the brown line.

Bank	Parameter			Function of Bank selection input				Selectable range
	Synchron	String+	SyncPlus	Orange/Black	Yellow/Black	Pink	Purple	
BKN	CONT	OFF	Others ON	Bank selection0	Bank slctn 1 String+	Bank slctn 2	Bank slctn 3	0-15
		ON,SCLR	Others ON					Bank slctn 1 String+
	UP,HIGH DOWN, LOW	OFF	Others ON	Pulse que Bank slctn0 String+	Bank slctn 1 String+	Synchron- ous input	0-7	
		ON,SCLR	Others ON				0,2,4,6 0,1,4,5 0,4	
TCH	CONT	OFF	Others ON	Bank selection0	Bank slctn 1 String+	External Teaching	Bank slctn 3	0-3, 8-11
		ON,SCLR	Others ON					Bank slctn 1 String+
	UP,HIGH DOWN, LOW	OFF	Others ON	Pulse que Bank slctn0 String+	Bank slctn 1 String+	Synchron- ous input	0-3	
		ON,SCLR	Others ON				0,2 0,1 0	
0-15, COMM	CONT	OFF	Others ON	NA	NA String+	NA	0-15 (Bank is set by parameter and through RS232I/F)	
		ON,SCLR	Others ON					NA String+
	UP,HIGH DOWN, LOW	OFF	Others ON	Pulse que NA String+	NA String+	Synchron- ous input	0-15 (Bank is set by parameter and through RS232I/F)	
		ON,SCLR	Others ON				NA String+	

Field of View

CVS4-N23W-R

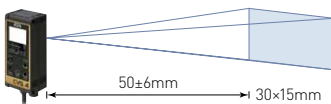

CVS4-N21W-R

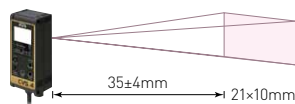

CVS4N23RW-R

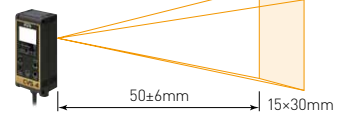

CVS4-N20W-R

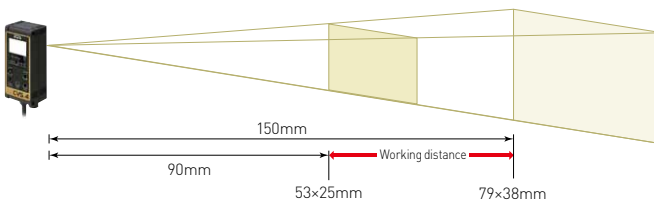

CVS4-N40W-R

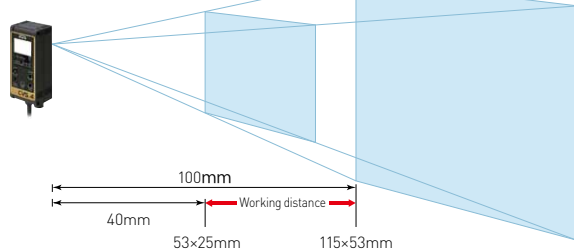

RS232 Communication

Available functions

1. Setup

You can download/modify/upload setup from/to CVS4-R.

2. User DIC

You can make unique character referring the image from CVS4-R.

3. Downloading NG image

You can refer NG image and check what happened.

4. Remote control

You can control CVS4-R through RS232 I/F.

5. Timer setup

You can set the timer of CVS4-R copying from PC.

6. Code recognition

You can modify code table that shows simple codes mean Date/Time.

Main menu

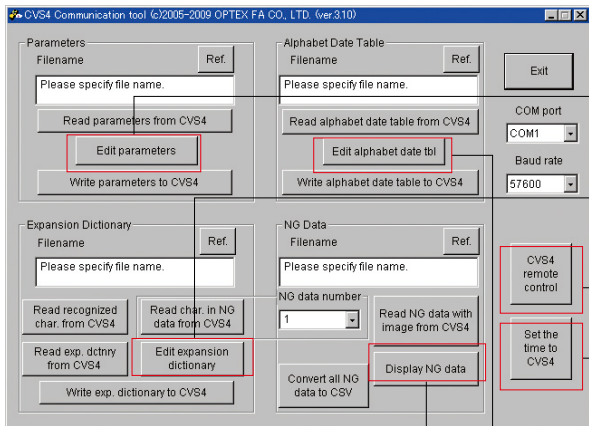

Required PC spec.
 - Microsoft Windows XP, 2000
 - RS232 I/F
 - Cable CVS-C2C

Downloadable from <http://www.optex-fa.com>

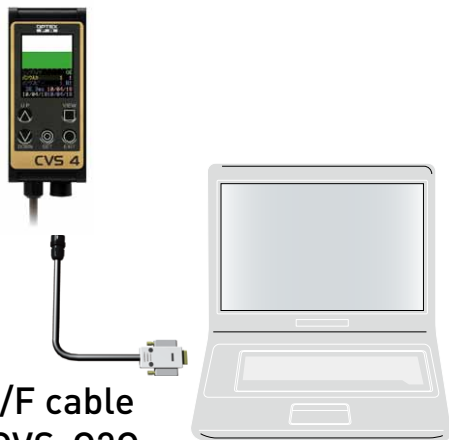

I/F cable CVS-C2C

1. Setup Modification

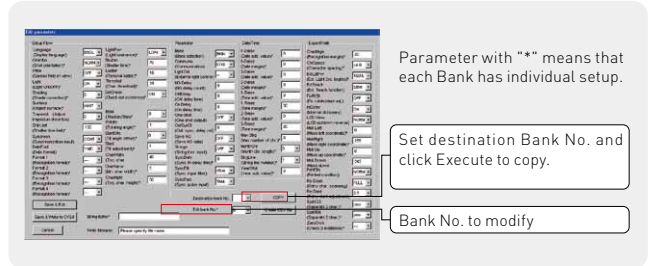

2. User Dictionary

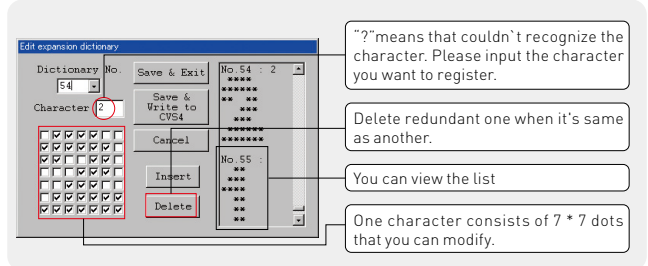

3. Downloading NG image



4. Remote control

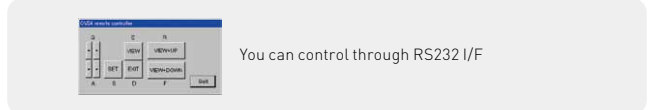

5. Timer setup

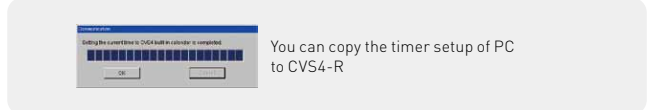

6. Code recognition

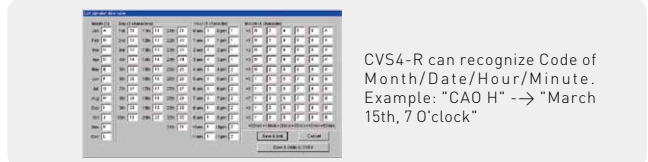

Accessories for CVS series

Remote monitor (with 3m cable)



CVS-M1-R
You can use for
CVS1-R, 2-R, 3-R, 4-R



CVSE-M1-R
Only for CVS1easy-R

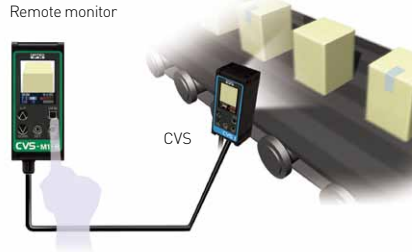

You can control from Remote monitor that has LCD and buttons to control remotely. The buttons work same as CVS series itself.

I/O Expansion unit



TMC-N11-CVS
With CVS2-R (only for color area mode) :
You can get sorting output up to 15 utilizing 4 output from CVS2-R
With CVS3-R and CVS4-R : You can use all Banks even using synchronous input and external teaching input
*You can't use for CVS1-R and CVS1easy-R

PC I/F cable (2m)

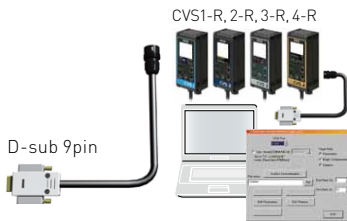

CVS-C2C
For CVS1-R, 2-R, 3-R, 4-R
You can download the I/F software from our homepage. You can setup CVS1-R, CVS2-R, CVS3-R and CVS4-R through each software and can get registered image. You can also modify mask area easily on the PC display.

Required PC spec.
- Microsoft Windows XP, 2000
- RS232 I/F
Software is downloadable from
<http://www.optex-fa.com>

Video cable (3m)

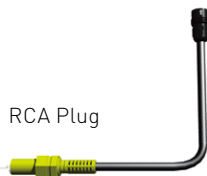

CVS-CN
For CVS series
You can see the display image connecting standard TV monitor (NTSC).

PC I/F cable + I/F cable for Video Out (2m)

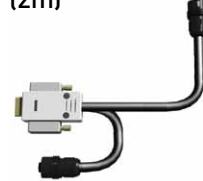

CVS-C2Y
For CVS1-R,2-R,3-R,4-R
You can connect PC and CVS-M1-R. You can see the screen image on the CVS-M1-R.
* You can't control through CVS-M1-R.

Extension cable for Remote monitor (3m)



CVS-C3S
For CVS-M1-R, CVSE-M1-R
You can connect Remote monitor through this cable up to 15m (4 CVS-C3S = 12m + 3m cable of Remote monitor)

PC I/F cable + Video cable (2m)



CVS-C2P(2m)
For CVS1-R,2-R,3-R,4-R
You can connect PC and get video signal at a time.

When you use TV monitor, please use it vertically



External light in CVS series shape



CVS-LW1(white color LED)
You can connect to CVS series up to 3 serially.

CVS-LU1(UV LED)
This lighting is effective for object with fluorescent printing to detect.

External LED lighting

When you need brighter lighting and/or lighting from other direction to get better image, you can utilize external LED lighting. Please refer Page 54 for other lighting and power supply.

Bar Light



OPB-5015W-B
50x15mm
OPB-10015W-B
100x15mm

OPDB-50x15WS

Power supply

For external LED lighting.



OPP-10-H(10W)

OPP-10-H(10W)
OPP-30-H(30W)
OPPD-15

Bracket for Lighting



2 OPDB-50x15WS and CVS-OPDB-2000

CVS-OPDB-2000
CVS-OPDB-3040
CVS-OPDB-6080



CVS-OP1000L
This is for mounting CVS series and external LED lighting.

Dimensions

CVS1-R/CVS2-R/ CVS3-R/CVS4-R

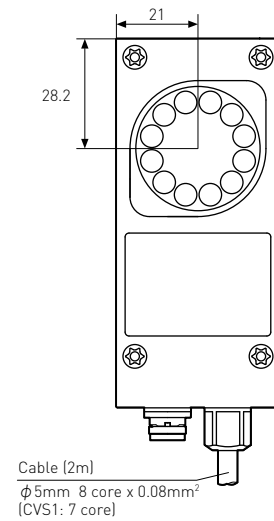
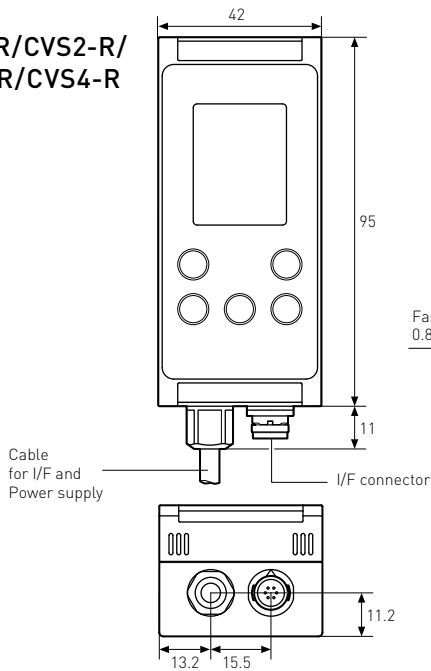

CVS1easy-R

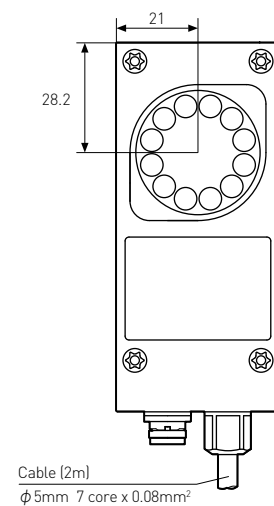
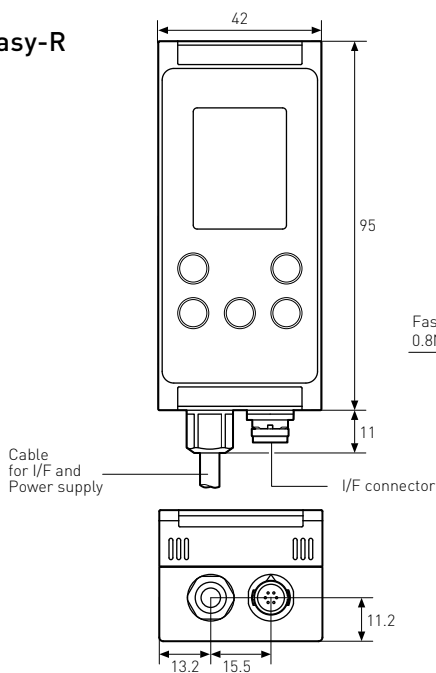

(unit: mm)

Tips for mounting CVS series

- Please determine Working distance and Field of View so that you chose correct model number of CVS series.
- Please use M4 * 50mm screws to mount CVS series
- Please take care about distance between CVS and target object to get stable size of Field of View.
- Please mount CVS at 15 to 45 degree to prevent specular reflection from the object especially from glossy object.
- When the object moves fast, you have to set shutter speed shorter. Then, you will need brighter lighting to get better image. Please try external lighting in this case.

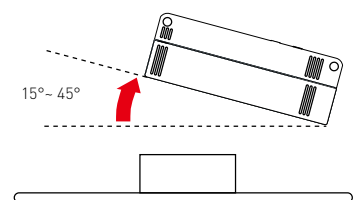

External light in CVS series shape
CVS-LW1(white color LED), CVS-LU1(UV LED)

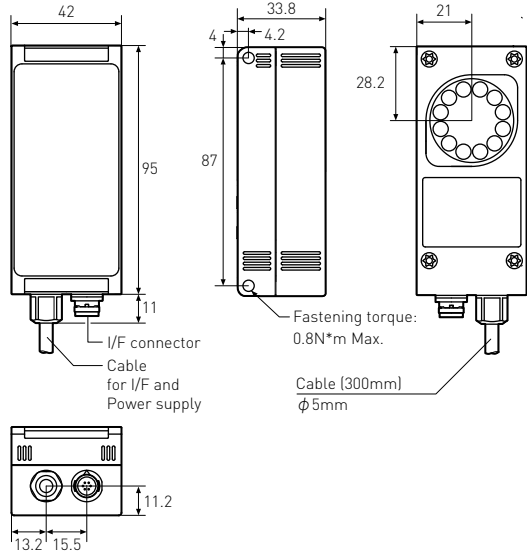

Bracket for Lighting
CVS-OPDB-2000

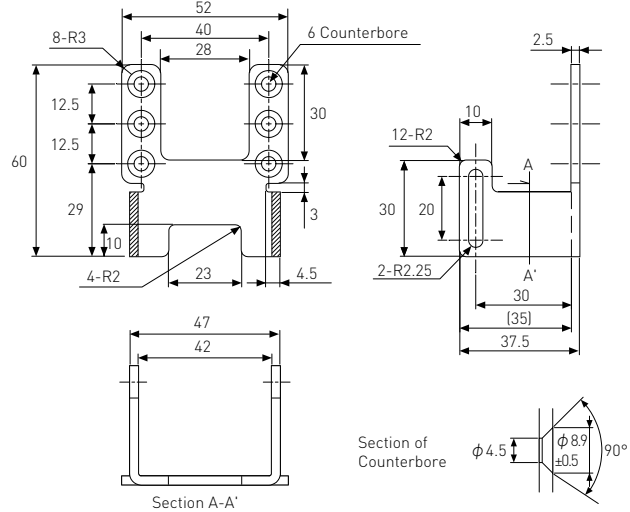

Remote monitor
CVS-M1-R

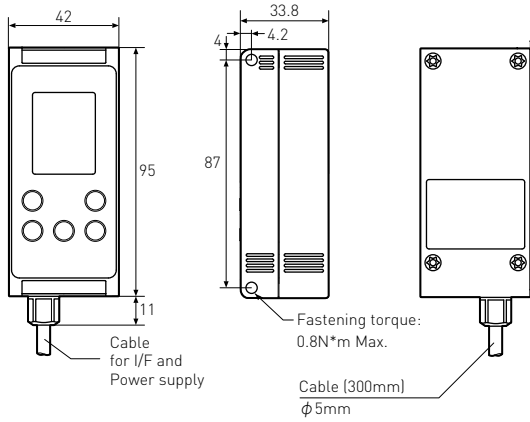

CVS-OPDB-3040

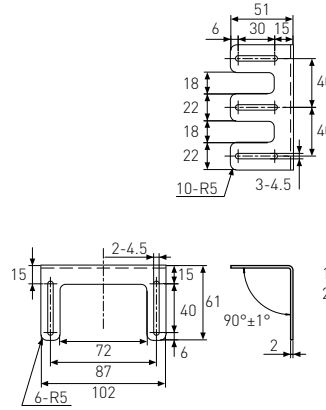

CVS-OPDB-6080

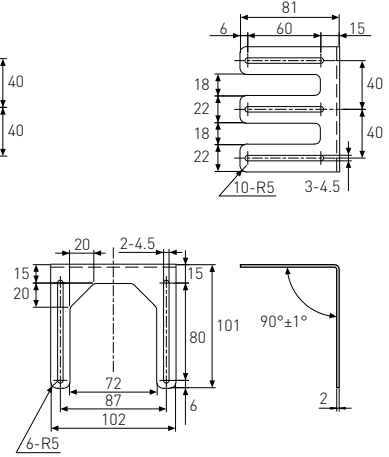

CVSE-M1-R

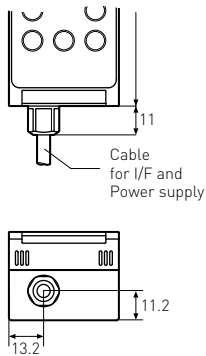

CVS-OP-1000L

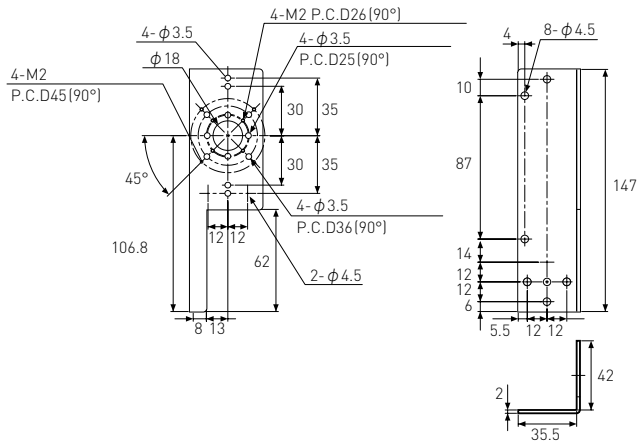

(unit: mm)

LED LIGHTING LINE UP

OPR
Sensing Ring Lights



OPB
Bar Lights



OPB-S
Sensing Bar Lights

OPDR
Direct Ring Lights



OPDR-F
Flat Direct Ring Lights



OPDR-LA
Low-angle Ring Lights



OPDR-H
Horizontal Ring Lights



OPDB
Bar Lights



OPIR, OPIR-S
Diffuse Ring Lights



OPLR
Diffuse Low-angle Ring Lights



OPLQ
Diffuse Low-angle Square Lights



OPSM
Surface Mount Back Lights



OPEM
Edge Mount Back Lights



OPCX
Coaxial Lights

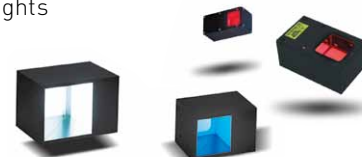

OPID
Diffuse Dome Lights



OPS, OPHS
Spot Lights



OPDB-RGB

Full color Diffuse Bar Lights



OPLR-RGB

Full color Diffuse Low-angle Ring Lights



UV

UV Lights



IR

Infrared Lights



OPPD

LED Controller



OPPF

Controller Advanced



OPPCW

Power Supply
(Dual output)



OPPA

Power Supply
(Parallel communication)



OPP, OPPW

Power Supply



DF

Diffuse Plate

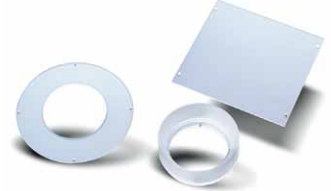

PL

Polarizing Plate

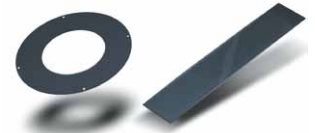

OP

Cable



OPAU

Arm Unit





<http://www.optex-fa.com>

OPTEX
FA **OPTEX FA CO., LTD.**

91, Chudoji Awata, Shimogyo-ku, Kyoto, 600-8815 Japan
TEL.+81- (0)75-325-2920 FAX.+81- (0)75-325-2921
<http://www.optex-fa.com>

78001-00-QL1204