

LDR2-90RD/SW/GR/BL

Model	LDR2-90RD	LDR2-90SW/GR/BL
Voltage	12V DC	24V DC
Power consumption	9.5W	15W
Mass	170g	170g
Connector type	2P(1: + , 2: -)	3P(1: + , 2: NC , 3: -)

Third Angle Projection Units: mm

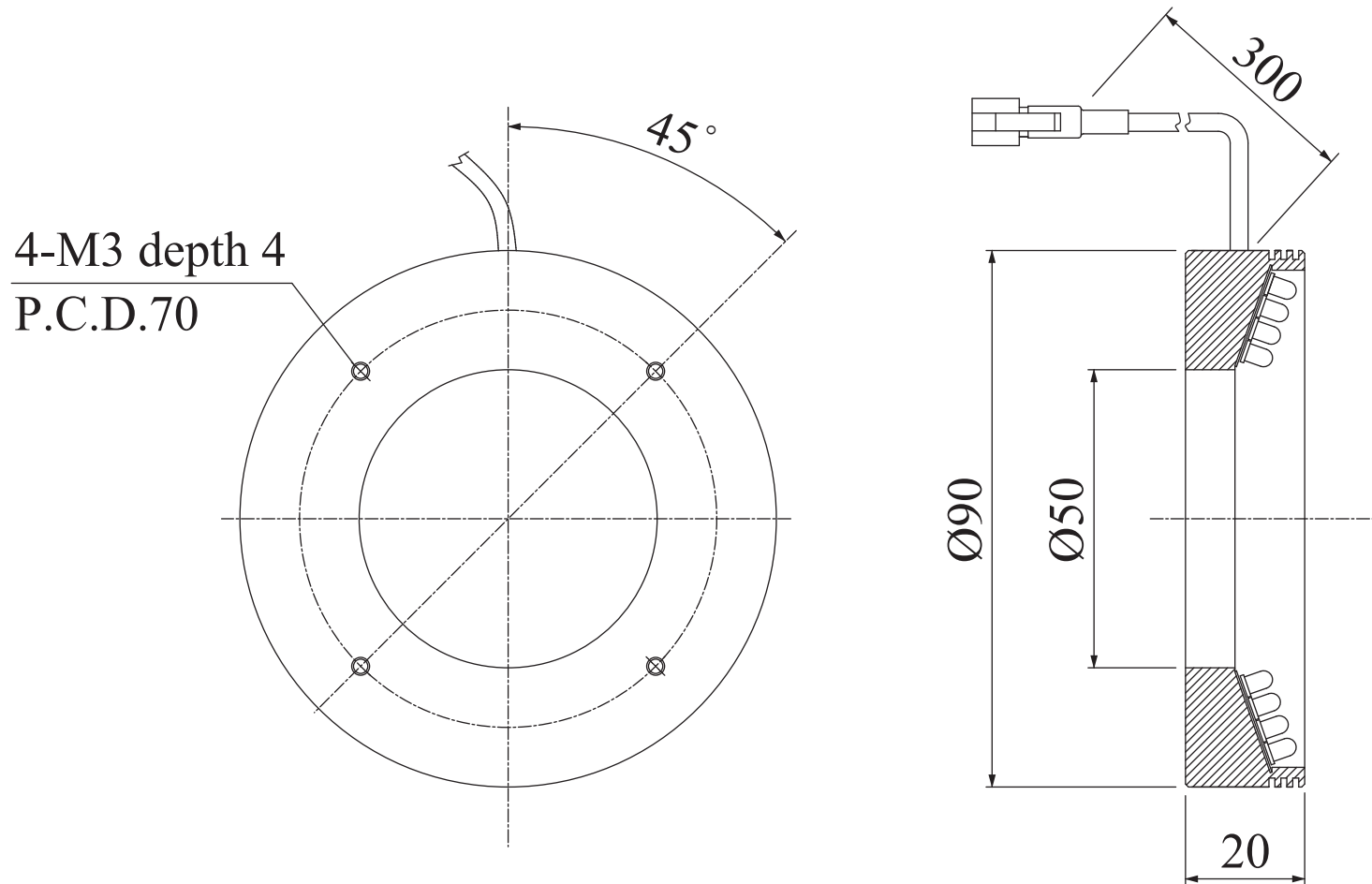



Ring Lights

LDR2/SQR Series

High-intensity light output, creating crisp vivid image

High-density LED arrays are arranged in an umbrella configuration, creating an extremely bright concentration of light at the center of the illumination area.

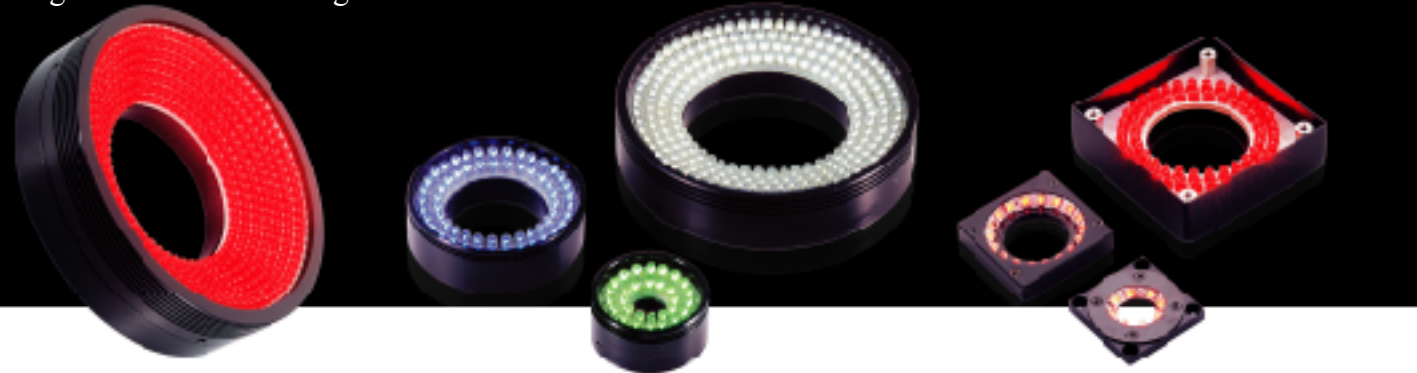

The CCS Original FFC System

CCS has established a manufacturing method using the FFC (Flexible board, Folded Conic) system. Using a flexible board makes it possible to improve product quality and increase manufacturing speed.

Flexible Board

Patent Pending



Using a flexible board makes it possible to create an illumination system optimized to the outer diameter, inner diameter, illumination angle, etc., for the object to be illuminated.

Significantly suppressing the temperature rise of LED

The LDR2 Series uses a special heat dissipating casing for warm environments and heat sensitive applications. This prevents the heat from building up in the LEDs, and increases both the life expectancy and the uniformity of the unit.

Structure of LDR2

Patent Pending

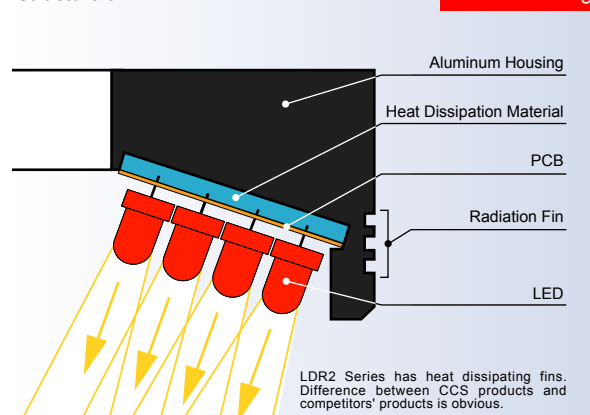

With conventional construction, LED lights are not able to dissipate heat with total efficiency due to the gap between the PCB and aluminum housing.

By employing a special heat dissipating enclosure between the PCB and the housing in CCS' new construction, there is substantial absorption of heat generation from LED, and efficient heat conductivity into the housing.

This new design suppresses the temperature rise of LED sharply, providing stable images for a long period of time.

Illumination Structure of LDR2-90

The flexible board is formed to the desired shape and a high-density LED array placed on the substrate. The light is concentrated at the center of the illumination system.

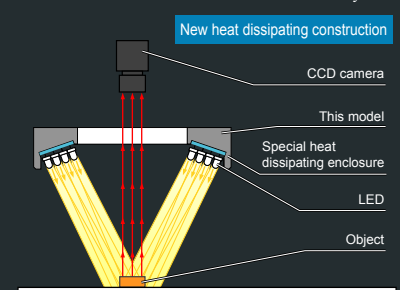

Examples of Ring Illumination Images

Lead Frame Inspection

The whole frame is illuminated from above using an LDR2 Series.

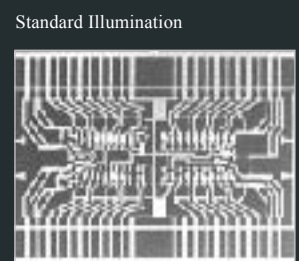

By decreasing the working distance of the illuminator, the silver plated sections of the lead frame become much more clear. Using an LDR2 Series



Image comparisons utilizing a polarizer

LED glare in the top half of the image distorts the image. Using a polarizing plate and filter can eliminate this glare, as shown in the bottom half of the image.

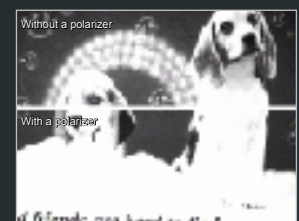

Product Lineup Table

Series	Model Name	Color	Power Consumption	Option	Dimension
LDR2	LDR2-32RD	●	12V/1.5W	D·P·A	1□
	LDR2-32SW/GR/BL	○/●/●	24V/2.0W	D·P·A	2
	LDR2-42RD	●	12V/2.1W	D·P·A	
	LDR2-42SW/GR/BL	○/●/●	24V/2.9W	D·P·A	3
	LDR2-50RD	●	12V/3.0W	D·P·A	
	LDR2-50RD-WD	●	12V/3.0W	D·P·A	4
	LDR2-50SW/GR/BL	○/●/●	24V/4.1W	D·P·A	
	LDR2-70RD	●	12V/6.0W	D·P*	5
	LDR2-70RD-WD	●	12V/6.0W	D·P*	
	LDR2-70SW/GR/BL	○/●/●	24V/8.2W	D·P*	6
	LDR2-90RD	●	12V/9.5W	D·P·A	
	LDR2-90RD-WD	●	12V/9.5W	D·P·A	7
LDR2-90SW/GR/BL	○/●/●	24V/15W	D·P·A		
LDR2-90-30RD	●	12V/14W	—	8□	
LDR2-90-30SW/GR/BL	○/●/●	24V/18W	—		
LDR2-120RD-WD	●	12V/24W	D·P·A	8□	
LDR2-120SW/GR/BL	○/●/●	24V/28W	D·P·A		

Series	Model Name	Color	Power Consumption	Option	Dimension
SQR	SQR-56	●	12V/3.0W	D·P	9
	SQR-56-N	●	12V/3.0W	D·P	
	SQR-56-SW/GR/BL	○/●/●	24V/4.1W	D·P	10
	SQR-TP-28-OR	●	12V/0.5W	—	
	SQR-TP-34-OR	●	12V/0.8W	—	

Notes:

- WD in the model name represents LED cone angle (±) 40° (refer to P.72).
- N in the model name represents LED cone angle (±) 20° (refer to P. 72).
- OR in the model name represents orange color LED lighting with a peak wavelength of 612 nm.
- Items marked with an asterisk under 'Options' are items with an adapter used for installation.

*1: LDR2 Series includes "SW2", white light with higher light intensity than "SW (white)". Please contact us for more details.

Dimensions (Unit: mm)

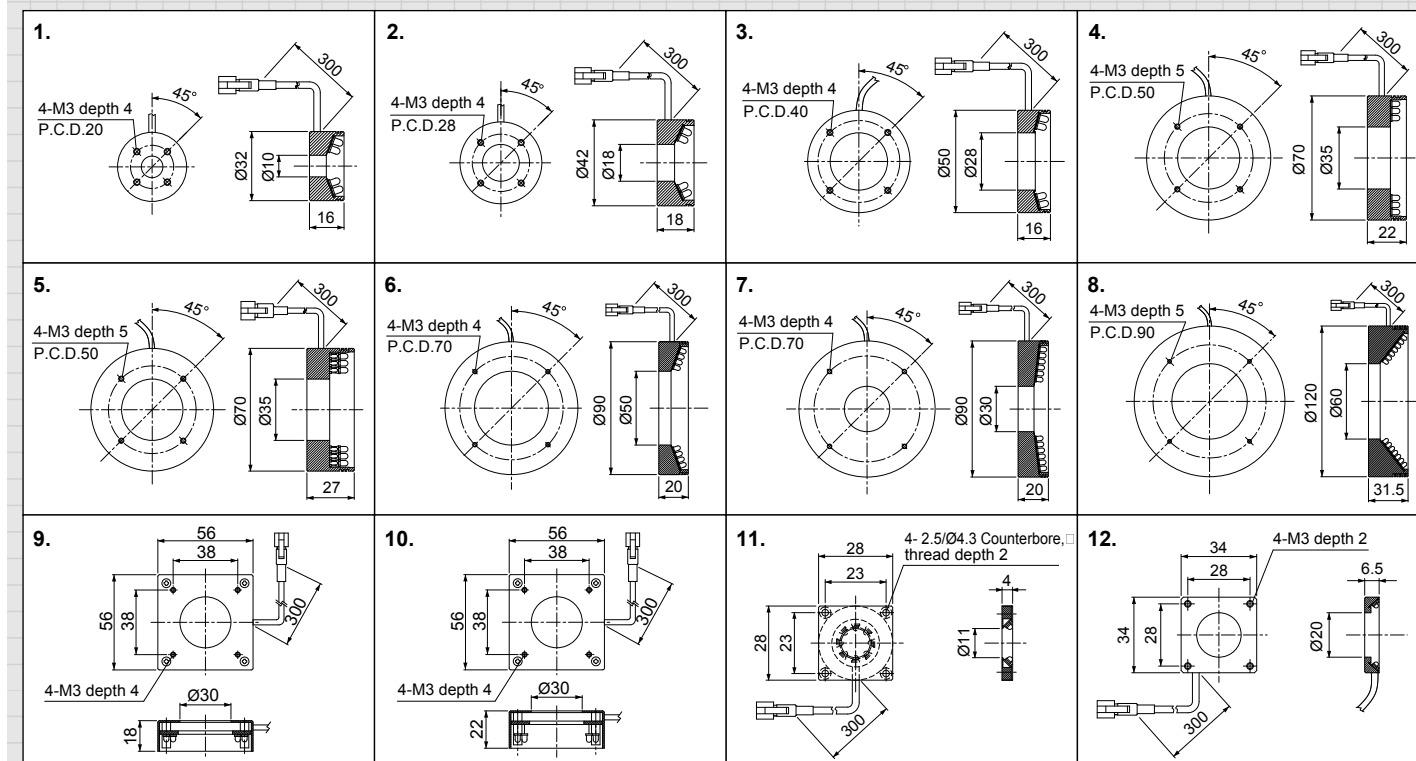

CCD Sensitivity Chart and Brightness Distribution LDR2-90

The highest intensity is achieved at the range of LWD 50-100 mm. Avoid using the light closer to the object, otherwise it will result in a dark area at the center of the illumination field.

CCD intensity vs LWD

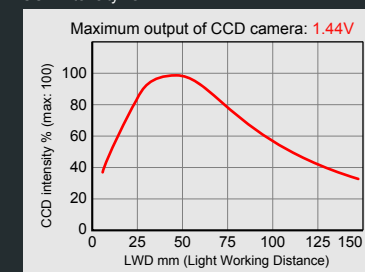

LWD: 50mm

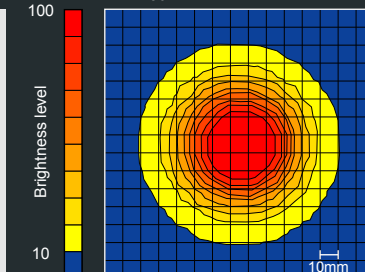

LWD: 100mm

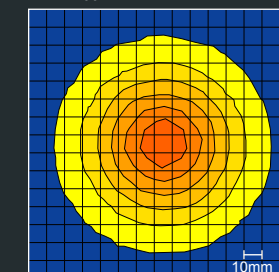

LWD: 150mm

