



S60-PL...M

Background suppression



INSTRUCTION MANUAL

CONTROLS

OUTPUT LED

The yellow/orange LED ON indicates that the N.O. (normally open) output is closed. Please refer to the "SETTING" paragraph for the correct setting procedure.

READY/ERROR LED (bi-coloured)

The bi-coloured LED turned green indicates a normal operating condition and hence the sensor is ready to function correctly (LASER ON).

The red blinking LED indicates a wrong sensor setting. In this case the emission and the green LASER ON LED are turned off.

SET PUSH-BUTTON

A long pressure on the pushbutton activates the self-setting procedure. The same external SET control of the sensor can be obtained using the REMOTE input.

INSTALLATION

The sensor can be positioned by means of the three housing's holes using two screws (M4x25 or longer, 1.5 Nm maximum tightening torque) with washers.

Various orientable fixing brackets to ease the sensor positioning are available (please refer to the accessories listed in the general catalogue).

The operating distance is measured from the front surface of the sensor optics.

The M12 connector can be oriented at two different positions using the specific fastening spring and rotating the block to 180°.



TECHNICAL DATA

Power supply:	10 ... 30 Vdc limit values
Ripple:	2 Vpp max.
Current consumption (output current excluded):	60 mA max.
Outputs:	PNP or NPN; 30 Vdc max. (short-circuit protection)
Output current:	100 mA max.
Output saturation voltage:	≤ 2 V
Response time:	500 μs max.
Switching frequency:	1 KHz
Indicators:	OUTPUT LED (YELLOW/ORANGE) / LASER ON/ERROR LED (GREEN /RED)
Setting:	SET pushbutton
Data retention:	EEPROM non volatile memory
Operating temperature:	-10 ... 55 °C
Storage temperature:	-20 ... 70 °C
Protezione elettrica:	Class 2
Operating distance (typical values):	5...10 cm
Spot dimension:	1.5 x 1 at 5 cm 1 x 1 at 7 cm 3 x 1.5 at 10 cm
Emission type:	RED LASER 650 nm: Class 1 EN 60825-1 (1994) Class II CDRH 21 CFR PART 1040.10
Ambient light rejection:	according to EN 60947-5-2
Vibrations:	0.5 mm amplitude, 10 ... 55 Hz frequency, for every axis (EN60068-2-6)
Shock resistance:	11 ms (30 G) 6 shock for every axis (EN60068-2-27)
DARK/LIGHT selection:	LIGHT mode with EASY TOUCH™ / automatic with fine detection
Housing material:	ABS
Lens material:	window in PMMA; lens in PC
Mechanical protection:	IP67
Connections:	2 m cable Ø 4 mm / M12-4 pole connector
Weight:	90 g. max. cable vers. / 40 g. max. connector vers.

CONNECTIONS

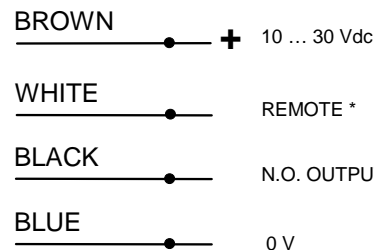

M12 CONNECTOR

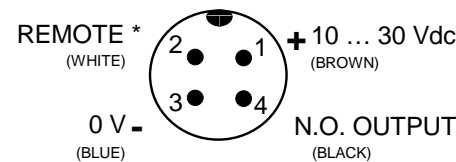

* = Connect to 0 V the REMOTE wire if not used.

SETTING

EASY TOUCH™

The sensor uses the patent-covered EASY TOUCH™ technology that allows a rapid and safe self-setting of the product.

Two different setting possibilities are available:

- **EASY TOUCH™**: press for 2 sec. the SET pushbutton to obtain the self-setting adjustment.
- **FINE DETECTION**: to be used only in particularly critical conditions, this setting procedure is used only when the EASY TOUCH™ is not sufficient.

EASY TOUCH™ (standard detection)

Place the background or the object to be suppressed inside the operating distance.

Press the SET pushbutton until the output LED turns OFF and then release it. The sensor is now ready to detect all objects in the defined operating range. The LIGHT mode is automatically set.

FINE DETECTION

Place the object to detect in front of the sensor at the desired distance.

Press the SET pushbutton and keep it pressed, without moving the object, until the output LED begins to blink. Release the button. Place the background to be suppressed. Press the SET pushbutton and wait until the output LED turns OFF and release the button.

According to the points detected the sensor selects the best operating condition and sets the LIGHT functioning mode. To select the opposite operating mode, invert the defined detection sequence.

If the red ERROR LED blinks the detection has failed due to insufficient contrast and the procedure has to be repeated from the beginning.

DIMENSIONS

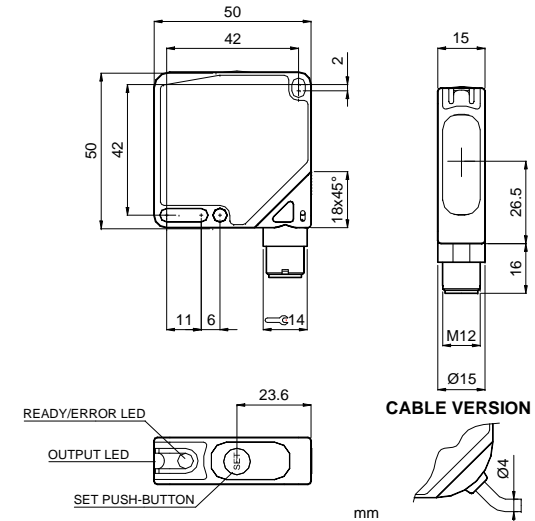

DELAY FUNCTION

Press the SET pushbutton and keep it pressed until the OUTPUT LED turns off, blinks and turns off again, then release the SET pushbutton. If the delay function *is not active* the OUTPUT LED blinks yellow/orange with 2 quick pulses.

If the delay function *is active* the OUTPUT LED blinks yellow/orange with 4 quick pulses. Press and release immediately the SET pushbutton in order to change the function status, the new function status is indicated by the OUTPUT LED as described beforehand. The delay function adds 20 ms to the duration of the sensor's ON pulse.

REMOTE FUNCTION

The REMOTE wire connected to + Vdc is equal to pressing the SET pushbutton. The *keyboard block* is activated if at the sensor powering the REMOTE wire is connected + Vdc, and thus the SET pushbutton is no longer active. To deactivate the *keyboard block* the sensor has to be turned off and then turned on with the REMOTE wire not connected to 0V.

DECLARATION OF CONFORMITY

We DATALOGIC AUTOMATION declare under our sole responsibility that these products are conform to the 2004/108/CE and successive amendments.



WARRANTY

DATALOGIC AUTOMATION warrants its products to be free from defects.

DATALOGIC AUTOMATION will repair or replace, free of charge, any product found to be defective during the warranty period of 36 months from the manufacturing date.

This warranty does not cover damage or liability deriving from the improper application of DATALOGIC AUTOMATION products.

DATALOGIC AUTOMATION

Via S. Vitalino 13
40012 Calderara di Reno
Bologna - Italy
Tel: +39 051 3147011
Fax: +39 051 3147453

Operations Office

Via Lavino 265
40050 Monte S. Pietro
Bologna - Italy
Tel: +39 051 6765611
Fax: +39 051 6759324

www.automation.datalogic.com e-mail:info.automation@datalogic.com

DATALOGIC AUTOMATION cares for the environment: 100% recycled paper. DATALOGIC AUTOMATION reserves the right to make modifications and improvements without prior notification.

Datalogic and the Datalogic logo are registered trademarks of Datalogic S.p.A. in many countries, including the U.S.A. and the E.U.