

Absolute-Encoder CDH75M - EPN + FS

Ref.: K-CDH75-PN-1

18.11.2013

010102007505020202

Advantages

- Functional safety
- Position feedback signals
- Redundant scanning system
- SIL3, PLe



General Data

Nominal voltage	
- Specific value	24 VDC
- Limit values, min/max	13/27 VDC
Supply	
- SELV/PELV	IEC 60364-4-41
Current consumption no load	<= 180 mA
Device design	
- Type	Multi-Turn
- Redundant scanning system	yes, double
Total resolution	<= 28 Bit
Number of steps per revolution	<= 8192
Number of revolutions	<= 32768
PROFINET IO - Interface	
- PROFINET IO – Device	IEC 61158, IEC 61784-1
- Physical Layer	Fast Ethernet, ISO/IEC 8802-3
- PROFINET-Specification	V2.2
- Conformance Class	B, C
- Real-Time-Classes	Class 1, 2 (RT), Class 3 (IRT)
- PROFIsafe-Profile	No. 3.192b
Incremental - Interface	
- Equipment	Standard interface
- Signal form	Square wave

Subject to change.

TR-Electronic GmbH
 Eglisshalde 6
 78647 Trossingen
 Tel. +49 (0) 7425 228-0
 info@tr-electronic.de
www.tr-electronic.de

Absolute-Encoder CDH75M - EPN + FS

Ref.: K-CDH75-PN-1

18.11.2013

010102007505020202

General Data continuation

- Signal form, alternative	SIN / COS
- Incremental signals, square	K1± K2±
- Incremental signals, SIN/COS	SIN± COS±, 1 V _{ss}
- Impulses, square wave	4096...20480, in steps of 4096
- Impulses, SIN/COS	4096 □
- Output driver, TTL	RS-422, 5 VDC
- Output driver, HTL	Push-Pull, 13...27 VDC
- Type of parametrization	Factory setting
Transmission rate	
- Specific value	100 MBit/s
Cycle time	>= 1000 µs (IRT/RT)
- Not safety related	0.5 ms
- Safety related	5 ms
Parameter/Function, changeable	Integration time
	Preset parameter
	Monitoring window
	Counting direction
	Velocity parameter
Type of parametrization	programmable
Prgramming - Tool	Fieldbus-Device
Functional safety	
- Safety principle	Redundance with cross compare
- SIL-Standardization	DIN EN 61508 / DIN EN 62061
- SIL-Level	SIL3 / SIL CL 3
- PL-Standardization	DIN EN ISO 13849
- Performance-Level (PL)	PLe / Kat. 4
- Service life	20 Years
- PFH, High demand	1.46E-9 1/h
- PFDav, T = 20 a	1.27E-4
- MTTFd, high	421 a
- DCavg, hig	95 %
Maximum Speed, mechanically	<= 3000 1/min
Shaft load, axial/radial	Own mass
Bearing life time	>= 3.9E+10 revolutions
Bearing life time - Parameter	
- Speed	1500 1/min
- Operating temperature	60 °C
Angular acceleration	<= 10E+4 rad/s ²

Subject to change.

Absolute-Encoder CDH75M - EPN + FS

Ref.: K-CDH75-PN-1

18.11.2013

010102007505020202

General Data continuation

Start-up torque, 20 °C	6 Ncm
Mass, typically	1 kg

Environmental conditions

Vibration	
- Specific value	$\leq 100 \text{ m/s}^2$
- Sine	50...2000 Hz
Shock	
- Specific value	$\leq 600 \text{ m/s}^2$
- Half sine	5 ms
Immunity to disturbance	DIN EN 61000-6-2
Transient emissions	DIN EN 61000-6-3
Working temperature	
- Standard	0...+60 °C
- Optional	-20...+70 °C;
- Note, optional temperature	with restricted functionality
- Note, optional temperature	Speed $\leq 300 \text{ 1/min}$
Storage temperature, dry	-30...+80 °C
Relative humidity	98 %, non condensing
Protection class	
- Standard	IP54

Subject to change.

Absolute-Encoder CDH75M - EPN + FS

Ref.: K-CDH75-PN-1

18.11.2013

010102007505020202

Dimensional drawing

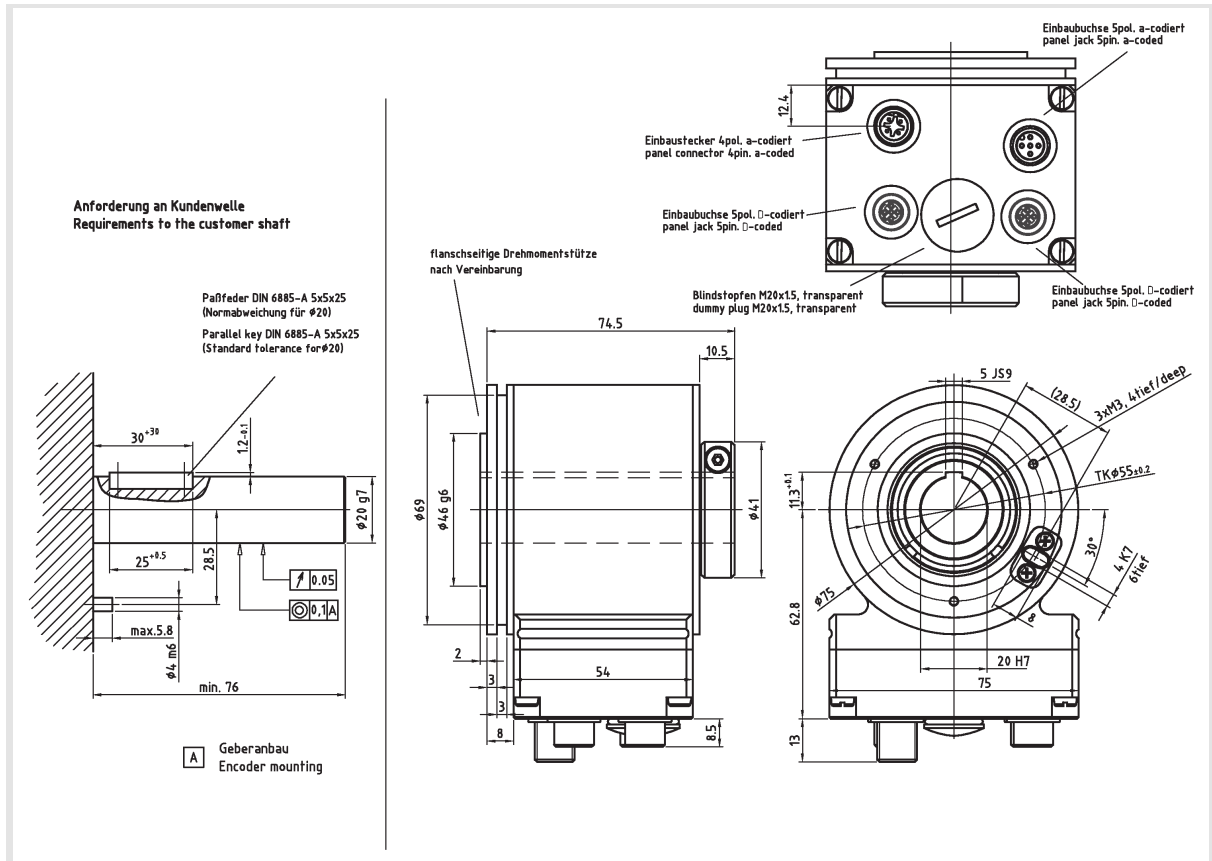

Suggested products

CDH75M*8192/32768 EPN 20H7NT +FS
TTL Inkr -20°...70° 4x M12

CDH75M-00013

Subject to change.