

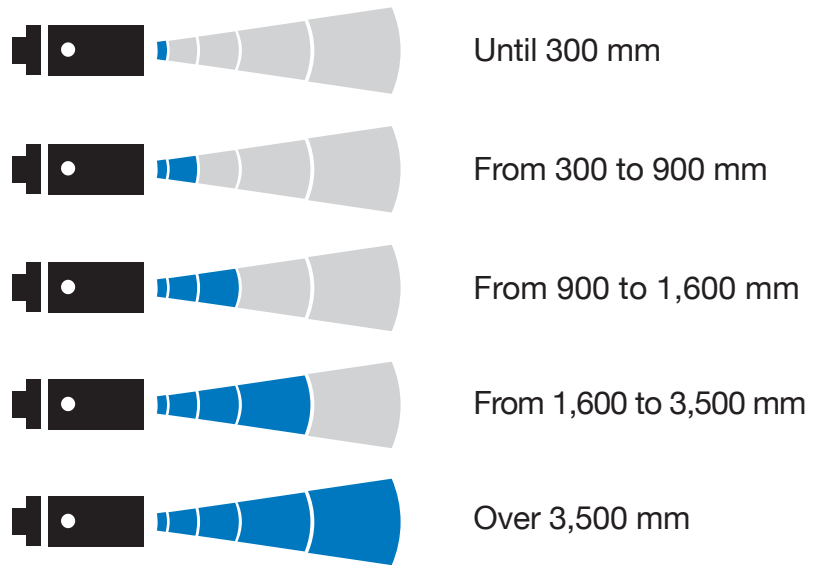

# Ultrasonic Sensors

### Nominal sensing distance







# Ultrasonic Sensor

## Basic theory



### Operation principle of ultrasonic sensor

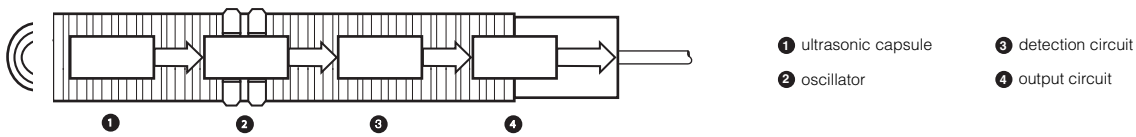

Ultrasonic sensors are composed by: ultrasonic transducer, oscillator, trigger circuit and output circuit. There are three working principles:

#### • direct diffusion

Ultrasonic transducer is energized by high voltage pulses and starts to emit an ultrasonic signal. The ultrasonic signal is reflected by the target towards the sensor. Trigger circuit measures the time between the emission and the detection of the signal. Since the speed of the ultrasonic beam in air is known, it is easy to have not only an indication of the presence of the target, but also a measure of the distance between sensor and target.

In diffuse models, the ultrasonic transducer works before as emitter and then as receiver. When it is in "emission mode" no signal can be detected. This imply that in front of the sensor there is a blind zone where the detection of objects is not possible or not reliable.

The dimension of the blind zone depends on the type of ultrasonic transducer used.

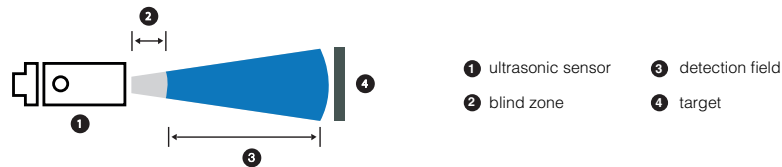

#### • retroreflection

To work correctly, it is necessary a background/reflector (any flat, orthogonal, fixed part). The sensor measures the distance between sensor and reflector. Any changes in this measure means that there is an object between sensor and reflector. In this case we don't have a blind zone, but we have to consider a minimum sensing distance between sensor and reflector: the object can be detected in the whole working area.

#### • emitter and receiver

There are two separate units: emitter and receiver. The receiver detects the signal from the emitter. If there is no signal, this means that there is an object between emitter and receiver.

### Considerations on targets tipology

Ultrasonic sensor can detect any kind of targets (more or less). The effective detection distance depends on: target dimensions (more the target is big, more ultrasonic signal is reflected, higher the sensing distance that it is possible to reach), materials (compact targets, as metal, wood, liquids, reflect a lot of the ultrasonic signal – low density materials, as powders, foams, absorb the majority of the ultrasonic beam). Sound absorbing materials can be detected only at very low distance.

In the direct diffuse sensors, other factors have to be considered:

#### • shape of the object

If the objects are perpendicular to the ultrasonic beam, the beam is reflected towards the sensor, and so the object is well detected. Objects with irregular or tilted shape, scatters the beam, so it is possible that they would not be detected.

#### • object temperature

Even if MD sensors are fully thermically compensated in the whole sensing range, a high thermal gradient between object and environment, can create turbulent air whirlpool that can distort the ultrasonic beam.

All the measures indicate in the catalogue are related to the standard target according EN60947-5-2. Users have to take care of the possible differences with real target used.

### Switching frequency

Switching frequency is the maximum output switching frequency performed by the output circuit when standard targets cross the sensing field. It is depending on: sensor's characteristics, target dimensions and size, distance from the targets.

### Hysteresis

Hysteresis is the difference between switch on and switch off position. It is necessary to avoid output oscillations if the target is vibrating or fixed close to the switching point.

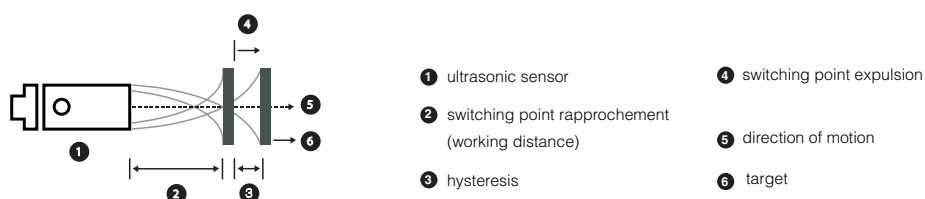



			working distance (mm)													
function	dimension	material	40...300	50...400	60...800	100...900	80 ... 1,200	200 ... 1,500	150 ... 1,600	200 ... 2,200	250 ... 3,500	350 ... 3,500	350 ... 6,000	800 ... 6,000	pag.	
direct diffuse	M18 short housing	plastic	UK6A		UK6C		UK6D								519	
		AISI316L	UK6A		UK6C		UK6D								519	
	M18 with Teach-In	plastic		UK1A		UK1C			UK1D	UK1F					509	
	M18 with Teach-In 90°			UK1A					UK1D	UK1F					509	
	M18 with Teach-In		AISI316L		UK1A		UK1C		UK1D						509	
	M30	plastic										UT1B				527
			AISI316L										UT1B			527
M30 large front	plastic												UT2F		527	
		metallic housing / plastic transducer												UT5L	527	

			working distance (mm)													
function	dimension	material	0...300	50...300	100...400	80...800	150...800	0...1,100	100 ... 1,200	200 ... 1,600	250 ... 2,000	250 ... 3,500	350 ... 3,500	350 ... 6,000	pag.	
retro reflective	M18 corpo corto	plastic		UKR6A		UKR6C			UKR6D						519	
	M18 with Teach-In				UKR1A		UKR1C			UKR1D	UKR1F				519	
	M30											UTR1B				509
	M30 large front													UTR2F		509
emitter/receiver	cubic		UHZ												509	
								UHS							509	

function	dimension	material	page
fork	fork for labels	metallic	541



# UK1 and UKR1 series

M18 cylindrical direct diffuse & retro-reflective Ultrasonic Sensor UK1 with Teach-In button



## features

- Models with digital programmable output
- Models with current or voltage analogue outputs
- Adjustable Hysteresis function: model with programmable double digital outputs, specific for levels
- Working area adjusting (window teach or single point teach) by Teach-in button suitable for all models for a fast coming into work
- Multifunction LED indicator: output type, adjustment procedure, NO/NC selection and reverse analog output slope

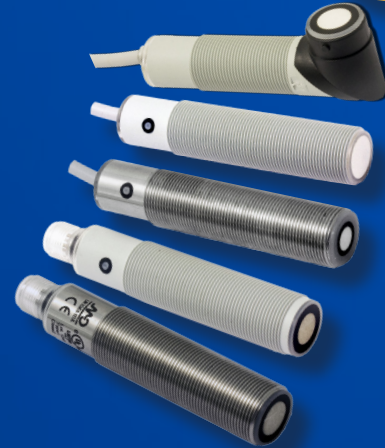

## web contents



- Application notes
- Photos
- Catalogue / Manuals



M18 with Teach-In button

## code description (\*)

UK 1 A / E 1 - 0 E UL AN

series	<b>UK</b>	M18 Ultrasonic Sensor
function	<b> </b>	Direct diffuse models
	<b>R</b>	Retroreflective models
housing type	<b>1</b>	Standard housing
nominal sensing distance Sn	<b>A</b>	50 - 400 mm (100 - 400 mm retroreflective models)
	<b>C</b>	100 - 900 mm (150 - 800 mm retroreflective models)
	<b>D</b>	150 - 1,600 mm (plastic models) / 200 - 1,500 mm (metallic models) (200 - 1,600 mm retroreflective models)
	<b>F</b>	200 - 2,200 mm (250 - 2,000 mm retroreflective models)
adjustment	<b>E</b>	Adjustment by Teach-In button
output	<b>1</b>	0...10 V single voltage analogue output
	<b>2</b>	4...20 mA single current analogue output
	<b>4</b>	NPN - NO/NC digital output + 4 ... 20 mA current analogue output
	<b>6</b>	PNP - NO/NC digital output + 4 ... 20 mA current analogue output
	<b>7</b>	PNP - NO/NC digital output + 0 ... 10 V voltage analogue output
	<b>9</b>	NPN - NO/NC digital output + 0 ... 10 V voltage analogue output
	<b>N</b>	NPN - NO/NC single digital output
	<b>P</b>	PNP - NO/NC single digital output
	<b>W</b>	PNP - two digital outputs with standard window and adjustable hysteresis functions
	<b>M</b>	NPN - two digital outputs with standard window and adjustable hysteresis functions
housing materials	<b>0</b>	Plastic housing
	<b>1</b>	AISI 316L (DIN 1.4404) stainless steel housing (axial)
	<b>2</b>	90° emission, plastic housing
cable exit / connector	<b>A</b>	Axial cable exit (2 m)
	<b>E</b>	M12 plug cable exit
cULus	<b>UL</b>	With cULus certification
ATEX	<b>AN</b>	ATEX certified, Cat.3 2.22 Zone

(\*) Multiplexing models and with synchronization available.

## available models

single digital output standard cULus certified available models

housing	output	distance (mm)	analogue output 0...10 V	analogue output 4...20 mA	1 x PNP - NO/NC	1 x NPN - NO/NC
plastic	M12 connector	50...400	UK1A/E1-0EUL	UK1A/E2-0EUL	UK1A/EP-0EUL	UK1A/EN-0EUL
		100...900	UK1C/E1-0EUL	UK1C/E2-0EUL	UK1C/EP-0EUL	UK1C/EN-0EUL
		150...1,600	UK1D/E1-0EUL	UK1D/E2-0EUL	UK1D/EP-0EUL	UK1D/EN-0EUL
		200...2,200	UK1F/E1-0EUL	UK1F/E2-0EUL	UK1F/EP-0EUL	UK1F/EN-0EUL
	cable	50...400	UK1A/E1-0AUL	UK1A/E2-0AUL	UK1A/EP-0AUL	UK1A/EN-0AUL
		100...900	UK1C/E1-0AUL	UK1C/E2-0AUL	UK1C/EP-0AUL	UK1C/EN-0AUL
		150...1,600	UK1D/E1-0AUL	UK1D/E2-0AUL	UK1D/EP-0AUL	UK1D/EN-0AUL
		200...2,200	UK1F/E1-0AUL	UK1F/E2-0AUL	UK1F/EP-0AUL	UK1F/EN-0AUL

## available models

double digital output standard cULus certified available models

housing	output	distance (mm)	2 x PNP - NO/NC	2 x NPN - NO/NC
plastic	M12 connector	50...400	UK1A/EW-0EUL	UK1A/EM-0EUL
		100...900	UK1C/EW-0EUL	UK1C/EM-0EUL
		150...1,600	UK1D/EW-0EUL	UK1D/EM-0EUL
		200...2,200	UK1F/EW-0EUL	UK1F/EM-0EUL
	cable	50...400	UK1A/EW-0AUL	UK1A/EM-0AUL
		100...900	UK1C/EW-0AUL	UK1C/EM-0AUL
		150...1,600	UK1D/EW-0AUL	UK1D/EM-0AUL
		200...2,200	UK1F/EW-0AUL	UK1F/EM-0AUL
stainless steel AISI 316L	M12 connector	50...400	UK1A/EW-1EUL	UK1A/EM-1EUL
		100...900	UK1C/EW-1EUL	UK1C/EM-1EUL
		200...1,500	UK1D/EW-1EUL	UK1D/EM-1EUL
		50...400	UK1A/EW-1AUL	UK1A/EM-1AUL
	cable	100...900	UK1C/EW-1AUL	UK1C/EM-1AUL
		200...1,500	UK1D/EW-1AUL	UK1D/EM-1AUL

## available models

analog and digital output cULus certified

housing	output	distance (mm)	1 x PNP - NO/NC + 1 x 4...20 mA	1 x NPN - NO/NC + 1 x 4...20 mA	1 x PNP - NO/NC + 1 x 0...10 V	1 x NPN - NO/NC + 1 x 0...10 V
plastic	M12 connector	50...400	UK1A/E6-0EUL	UK1A/E4-0EUL	UK1A/E7-0EUL	UK1A/E9-0EUL
		100...900	UK1C/E6-0EUL	UK1C/E4-0EUL	UK1C/E7-0EUL	UK1C/E9-0EUL
		150...1,600	UK1D/E6-0EUL	UK1D/E4-0EUL	UK1D/E7-0EUL	UK1D/E9-0EUL
		200...2,200	UK1F/E6-0EUL	UK1F/E4-0EUL	UK1F/E7-0EUL	UK1F/E9-0EUL
	cable	50...400	UK1A/E6-0AUL	UK1A/E4-0AUL	UK1A/E7-0AUL	UK1A/E9-0AUL
		100...900	UK1C/E6-0AUL	UK1C/E4-0AUL	UK1C/E7-0AUL	UK1C/E9-0AUL
		150...1,600	UK1D/E6-0AUL	UK1D/E4-0AUL	UK1D/E7-0AUL	UK1D/E9-0AUL
		200...2,200	UK1F/E6-0AUL	UK1F/E4-0AUL	UK1F/E7-0AUL	UK1F/E9-0AUL
stainless steel AISI 316L	M12 connector	50...400	UK1A/E6-1EUL	UK1A/E4-1EUL	UK1A/E7-1EUL	UK1A/E9-1EUL
		100...900	UK1C/E6-1EUL	UK1C/E4-1EUL	UK1C/E7-1EUL	UK1C/E9-1EUL
		200...1,500	UK1D/E6-1EUL	UK1D/E4-1EUL	UK1D/E7-1EUL	UK1D/E9-1EUL
		50...400	UK1A/E6-1AUL	UK1A/E4-1AUL	UK1A/E7-1AUL	UK1A/E9-1AUL
	cable	100...900	UK1C/E6-1AUL	UK1C/E4-1AUL	UK1C/E7-1AUL	UK1C/E9-1AUL
		200...1,500	UK1D/E6-1AUL	UK1D/E4-1AUL	UK1D/E7-1AUL	UK1D/E9-1AUL

## available models

cULus and ATEX certified

housing	output	distance	analogue output 0...10 V	analogue output 4...20 mA	1 x PNP - NO/NC	1 x NPN - NO/NC + 1 x 4...20 mA	1 x PNP - NO/NC + 1 x 0...10 V
plastic	M12 connector	50...400	UK1A/E1-0EULAN	UK1A/E2-0EULAN	UK1A/EP-0EULAN	UK1A/E6-0EULAN	UK1A/E7-0EULAN
		100...900	UK1C/E1-0EULAN	UK1C/E2-0EULAN	UK1C/EP-0EULAN	UK1C/E6-0EULAN	UK1C/E7-0EULAN
		150...1.600	UK1D/E1-0EULAN	UK1D/E2-0EULAN	UK1D/EP-0EULAN	UK1D/E6-0EULAN	UK1D/E7-0EULAN
		200...2.200	UK1F/E1-0EULAN	UK1F/E2-0EULAN	UK1F/EP-0EULAN	UK1F/E6-0EULAN	UK1F/E7-0EULAN



M18 with  
Teach-In button

## technical specifications

cULus certified models

	UK1A/E*-**UL	UK1C/E*-**UL	UK1D/E*-**UL	UK1F/E*-**UL
maximum sensing distance	400 mm <sup>(1)</sup>	900 mm <sup>(2)</sup>	1,600 mm <sup>(2)</sup> 1,500 mm <sup>(2)</sup>	2,200 mm <sup>(2)</sup>
minimum sensing distance	50 mm	100 mm	150 mm 200 mm	200 mm
sensing range (Sd)	50...400 mm	100...900 mm	150...1,600 mm (plastic) 200...1,500 mm (metal)	200...2,200 mm
beam angle	± 8° / ± 7°	± 7°	± 8° / ± 7°	± 7°
switching frequency (digital output)	10 Hz	4 Hz	2 Hz / 1Hz	1 Hz
response time (digital output)	500 ms	≤ 125 ms	250 ms / 500 ms	500 ms
hysteresis	1%			
repeatability	0.5%			
resolution	1 mm	2 mm	3 mm	3 mm
linearity error	1%			
temperature range	- 20°C...+ 60°C			
temperature compensation	●			
operating voltage	15 - 30 Vcc			
temperature drift	5%			
ripple	≤ 7%			
leakage current	10 µA @ 30 Vcc			
output voltage drop	2.2 V max. (IL = 100 mA)			
no-load supply current	≤ 50 mA			
output current (digital output)	100 mA <sup>(3)</sup>			
minimum load resistance (analog voltage output)	3 k Ω			
set point adjustment	Teach-In button			
power on delay	≤ 500 ms (digital output) ≤ 900 ms (analogue output)			
power supply protections	polarity reversal, transient			
digital output protections	short circuit (auto reset), overvoltage pulses			
analogical electrical protections	overvoltage pulses			
EMC	conforming to EMC Directive, according to EN 60947-5-2			
protection degree	IP67 (EN60529) <sup>(4)</sup>			
housing material	PBT/stainless steel AISI 316L			PBT
active head material	Epoxy-Glass resin			
tightening torque	1 Nm plastic housing / 50 metallic housing			1 Nm
weight	plastic version: 70 g connector / 110 g cable metallic version: 100 g connector / 170 gr cable			
storage temperature	- 35°C...+ 70° without freezing			

(1) Metallic target 100 x 100 mm (2) Metallic target 200 x 200 (3) Available models without cULus certified with output current: 500 mA (models with single or double digital output); 300 mA (models with digital and analog output) (4) Protection guarantee only with plug cable well mounted

UK1 - UKR1





## available models

### retroreflective models

housing	material	output	distance (mm)	PNP - NO/NC	NPN - NO/NC
M18	plastic	M12	100...400	UKR1A/EP-0EUL	UKR1A/EN-0EUL
			150...800	UKR1C/EP-0EUL	UKR1C/EN-0EUL
			200...1,600	UKR1D/EP-0EUL	UKR1D/EN-0EUL
			250...2,000	UKR1F/EP-0EUL	UKR1F/EN-0EUL
		cable	100...400	UKR1A/EP-0AUL	UKR1A/EN-0AUL
			150...800	UKR1C/EP-0AUL	UKR1C/EN-0AUL
			200...1,600	UKR1D/EP-0AUL	UKR1D/EN-0AUL
			250...2,000	UKR1F/EP-0AUL	UKR1F/EN-0AUL

## technical specifications

### retroreflective models

	UKR1A/E*-*E	UKR1C/E*-*E	UKR1D/E*-*E	UKR1F/E*-*E
nominal sensing distance	400 mm	800 mm	1,600 mm	2,000 mm
reflector minimum sensing distance	100 mm	150 mm	200 mm	250 mm
beam angle	±8°	±7°	± 8°	± 7°
switching frequency	8 Hz	3 Hz	1 Hz	1 Hz
operating voltage	15...30 Vdc			
max. ripple content	5%			
output type	PNP or NPN NO/NC selectable			
output current	100 mA			
output voltage drop	≤ 2.2 V (@ I = 100mA)			
no-load supply current	≤ 50 mA @ Val=24V			
leakage current	≤ 10 µA @ 30V			
power on delay	≤ 500 ms			
ambient temperature range	- 20°C...+ 60°C			
temperature drift of Sr	≤ 5 %			
short-circuit protection	● (autoreset)			
induction protection	●			
voltage reversal protection	●			
weight	26 g			
LEDs	yellow: exit			
protection degree	IP67			
EMC	IEC60947-5-2			
housing material	plastic housing PBT			
active head material	glass resin			
connection	M12 plug cable exit			
weight	70 g connector / 100 g cable			

M18 with Teach-In button

UK1 - UKR1

## available models

### 90° emission models

housing	material	output	distance (mm)	PNP - NO/NC 0...10 V	NPN - NO/NC 0...10 V	PNP - NO/NC 4...20 mA	NPN - NO/NC 4...20 mA	2 x PNP hysteresis/window	2 x NPN hysteresis/window
M18	plastic	M12	50...400	UK1A/E7-2EUL	UK1A/E9-2EUL	UK1A/E6-2EUL	UK1A/E4-2EUL	UK1A/EW-2EUL	UK1A/EM-2EUL
			150...1.600	UK1D/E7-2EUL	UK1D/E9-2EUL	UK1D/E6-2EUL	UK1D/E4-2EUL	UK1D/EW-2EUL	UK1D/EM-2EUL
			200...2.200	UK1F/E7-2EUL	UK1F/E9-2EUL	UK1F/E6-2EUL	UK1F/E4-2EUL	UK1F/EW-2EUL	UK1F/EM-2EUL



M18 with  
Teach-In button

## technical specifications

### 90° emission models

	UK1A/E*-2EUL	UK1D/E*-2EUL	UK1F/E*-2EUL
nominal sensing distance	400 mm	1,600 mm	2,200 mm
minimum sensing distance	50 mm	150 mm	200 mm
sensing range	50...400 mm	150...1,600 mm	200...2,200 mm
beam angle	± 8°	± 8°	± 7°
hysteresis	1%		
repeatability	0.5%		
switching frequency	10 Hz	2 Hz	1 Hz
response time	500 ms		
operating voltage	15...30 Vdc		
max. ripple content	7%		
output current	100 mA (digital output)		
output voltage drop	≤ 2.2 V (@ I = 100mA)		
no-load supply current	≤ 50 mA		
leakage current	≤ 10 µA @ 30V		
power on delay	≤ 900 mA		
ambient temperature range	- 20°C...+ 60°C		
temperature drift of Sr	≤ 5%		
short-circuit protection	● (autoreset)		
induction protection	●		
voltage reversal protection	●		
weight	75 g		
LEDs	green: echo - yellow: output		
protection degree	IP67		
housing material	plastic housing: PBT		
active head material	glass reinforced epoxy resin		
connection	M12 plug cable exit		



M18 with Teach-In button

# electrical diagrams of connections

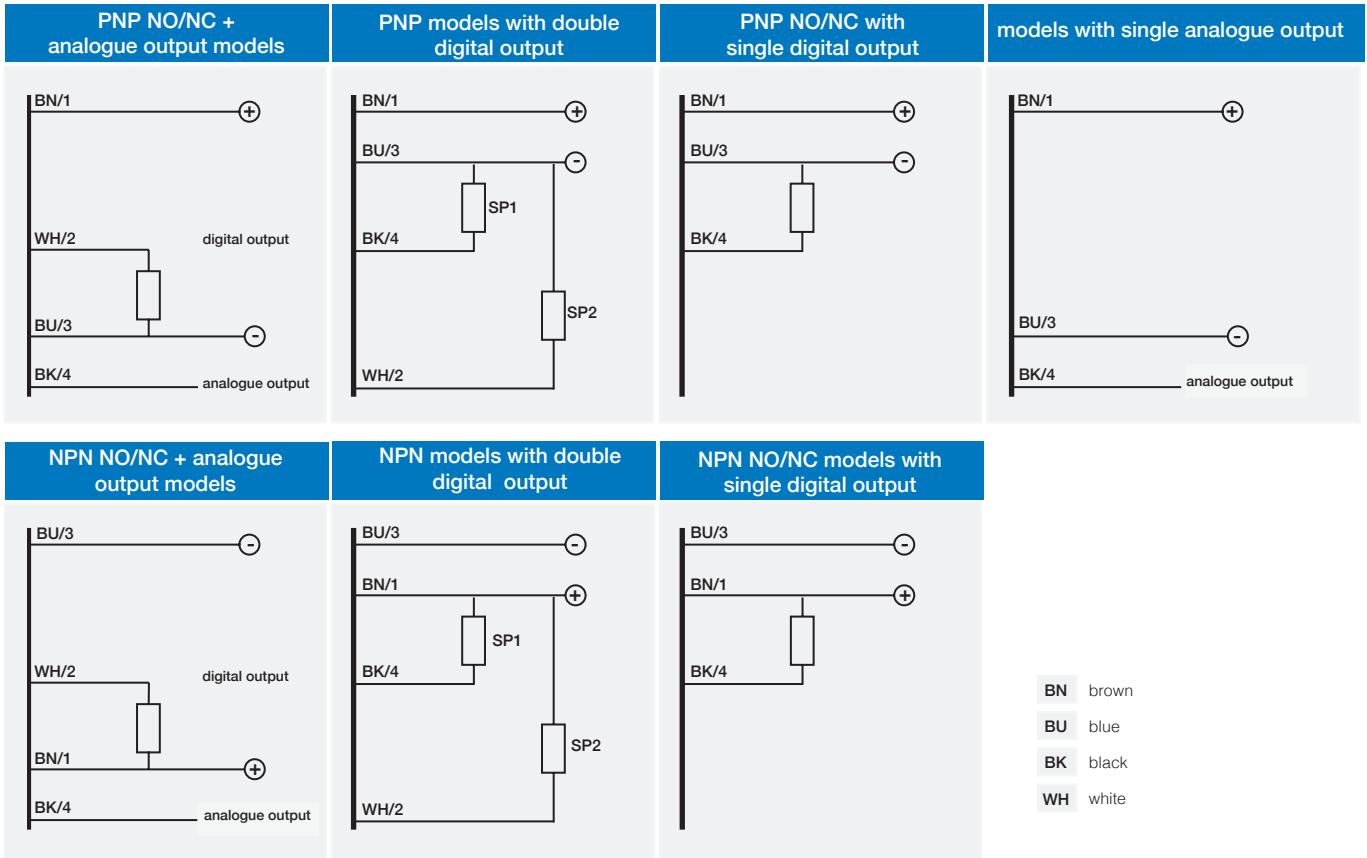

# connectors

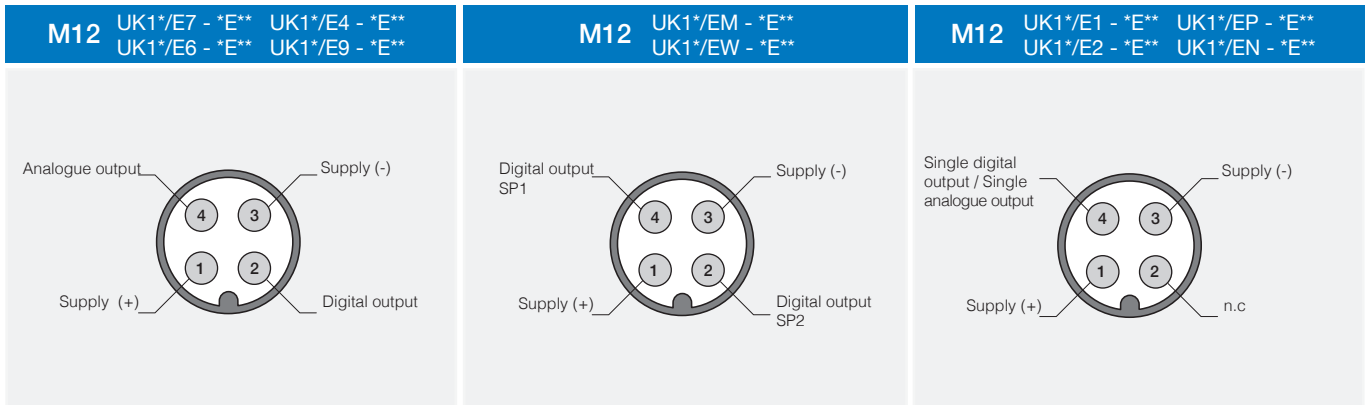

models with single digital output

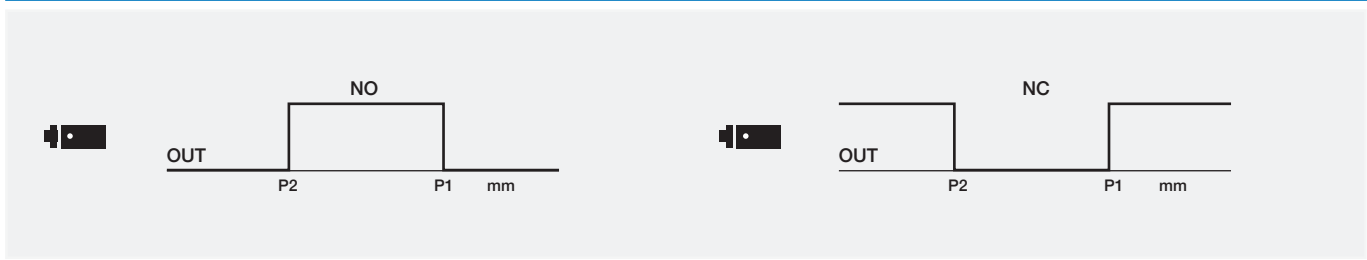

models with single analogue output

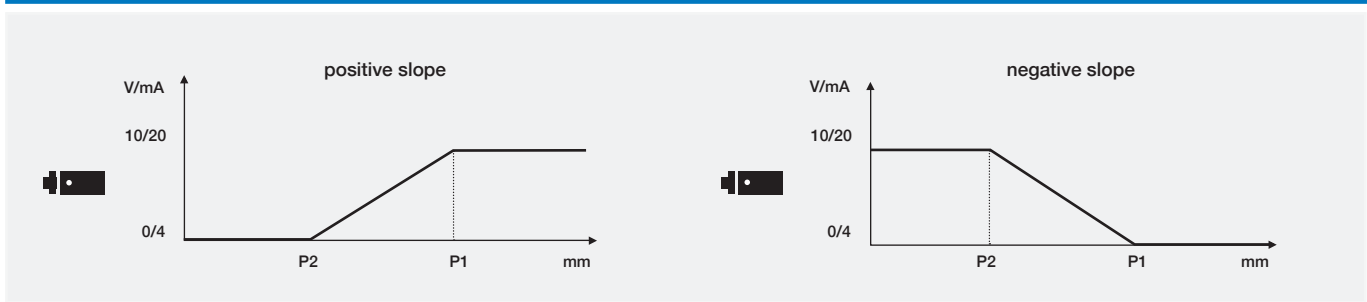

models with double digital output - standard window and adjustable hysteresis outputs

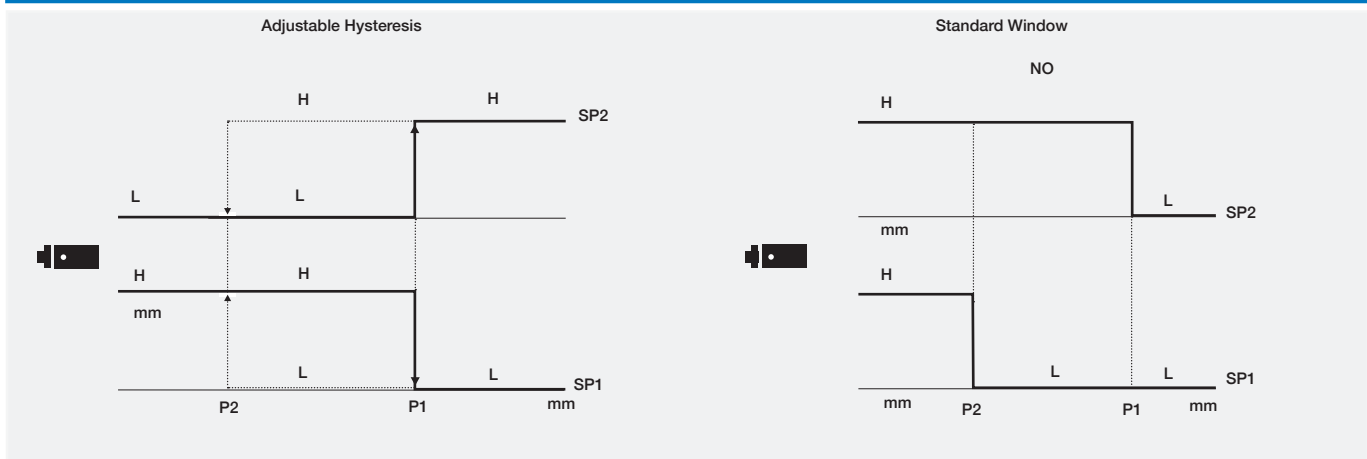

models with digital output + analogue output <sup>(1)</sup>

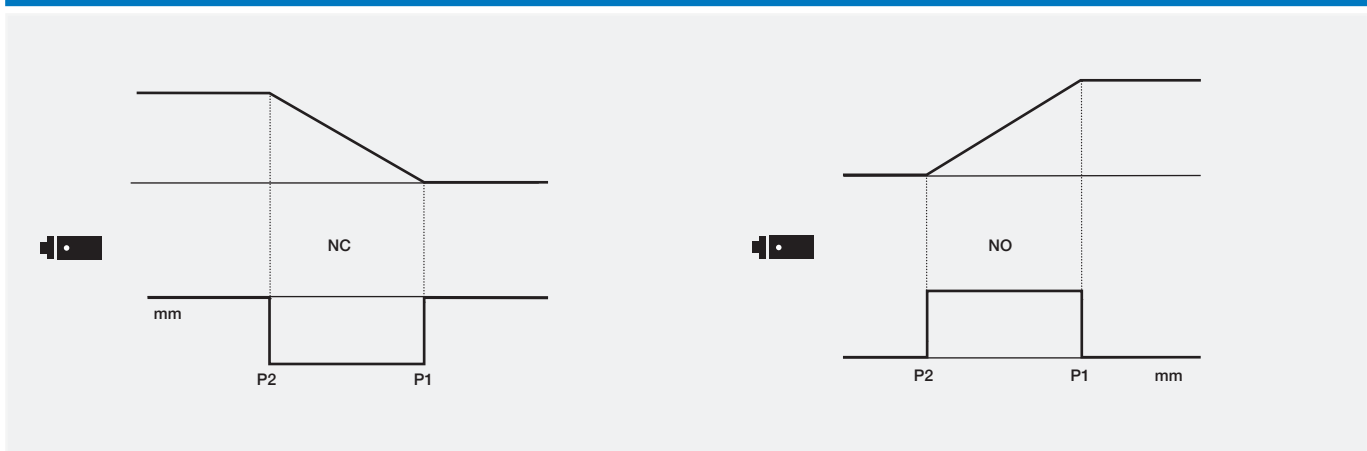

<sup>(1)</sup> It can be used as a single model output

- P1** maximum selected working distance and first point to select
- P2** minimum selected working distance and second point to select



# response diagrams

direct diffuse models

M18 with Teach-In button

UK1A/\*\*-\*\* parallel displacement

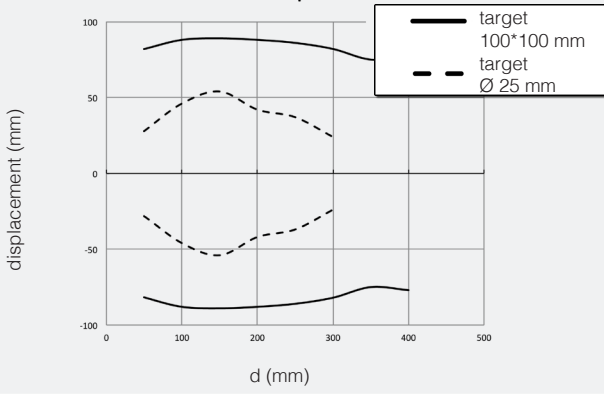

UK1C/\*\*-\*\* parallel displacement

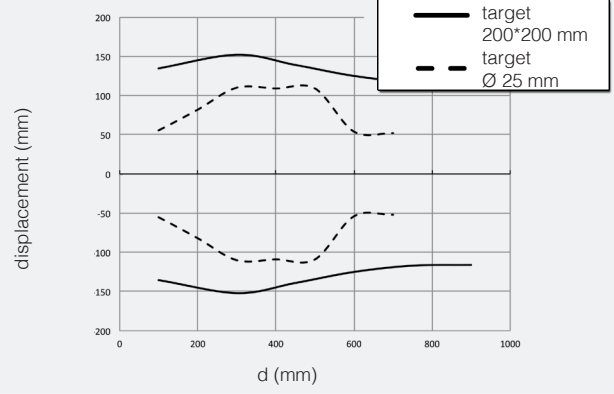

UK1D/\*\*-\*\* parallel displacement

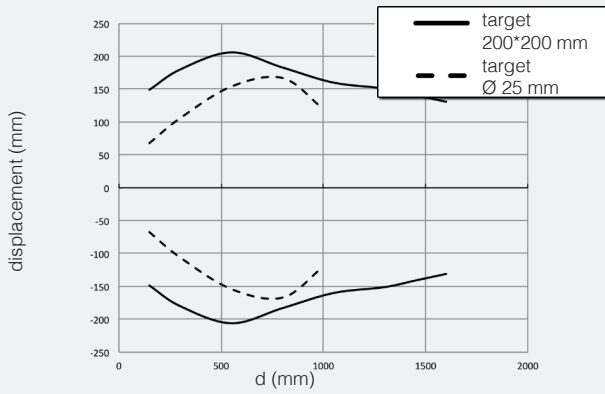

UK1F/\*\*-\*\* parallel displacement

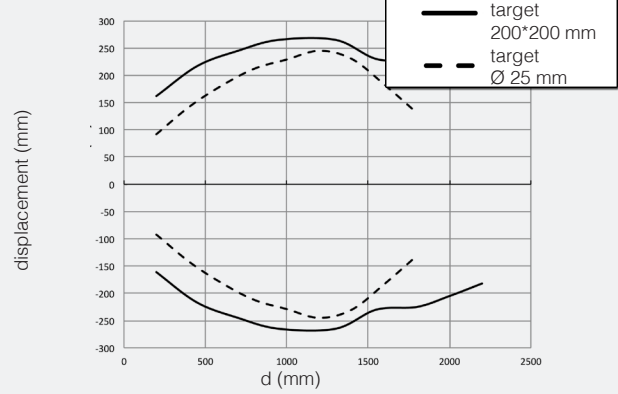

# response diagrams

retroreflective models



M18 with Teach-In button

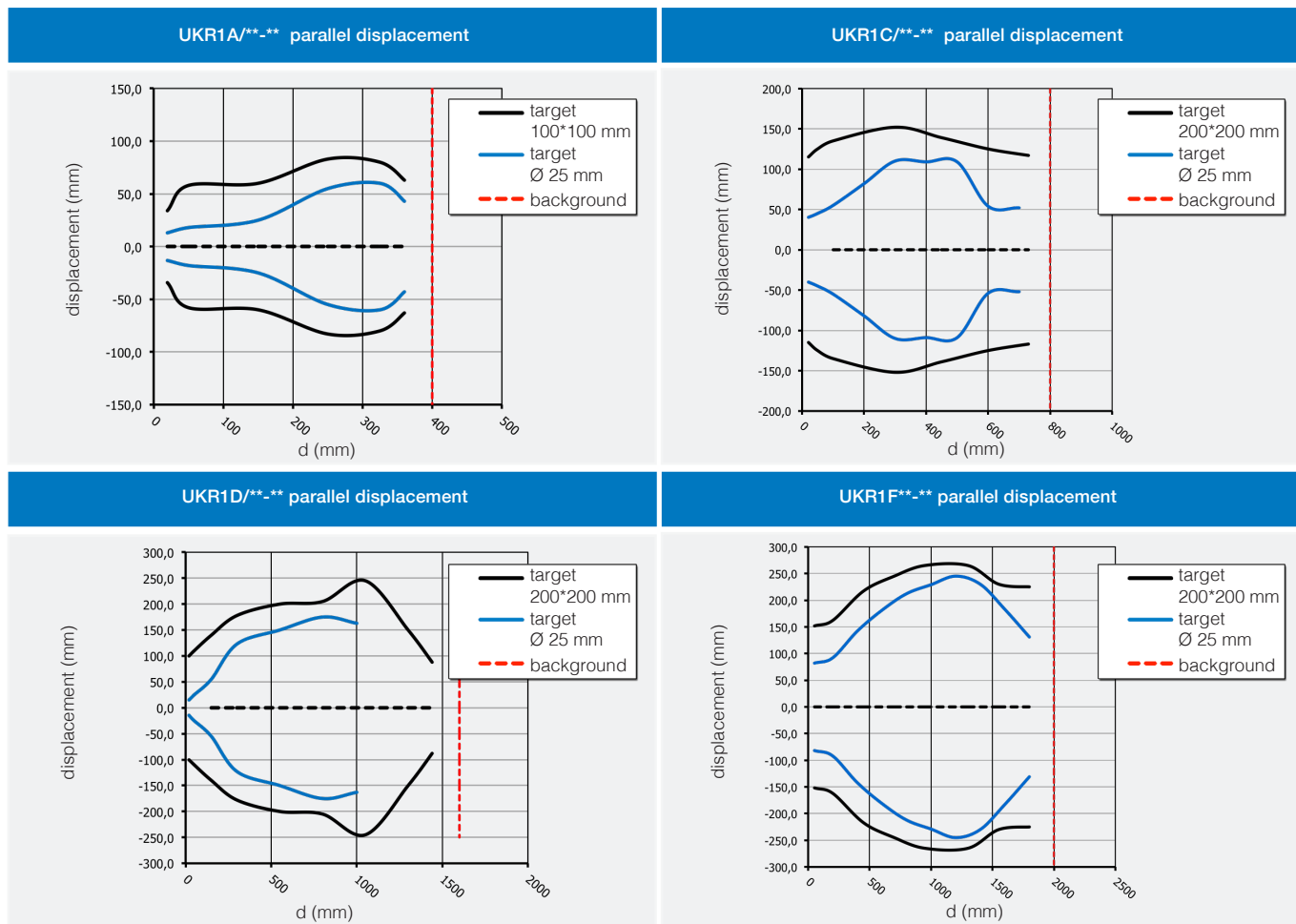

# dimensions (mm)

plastic models

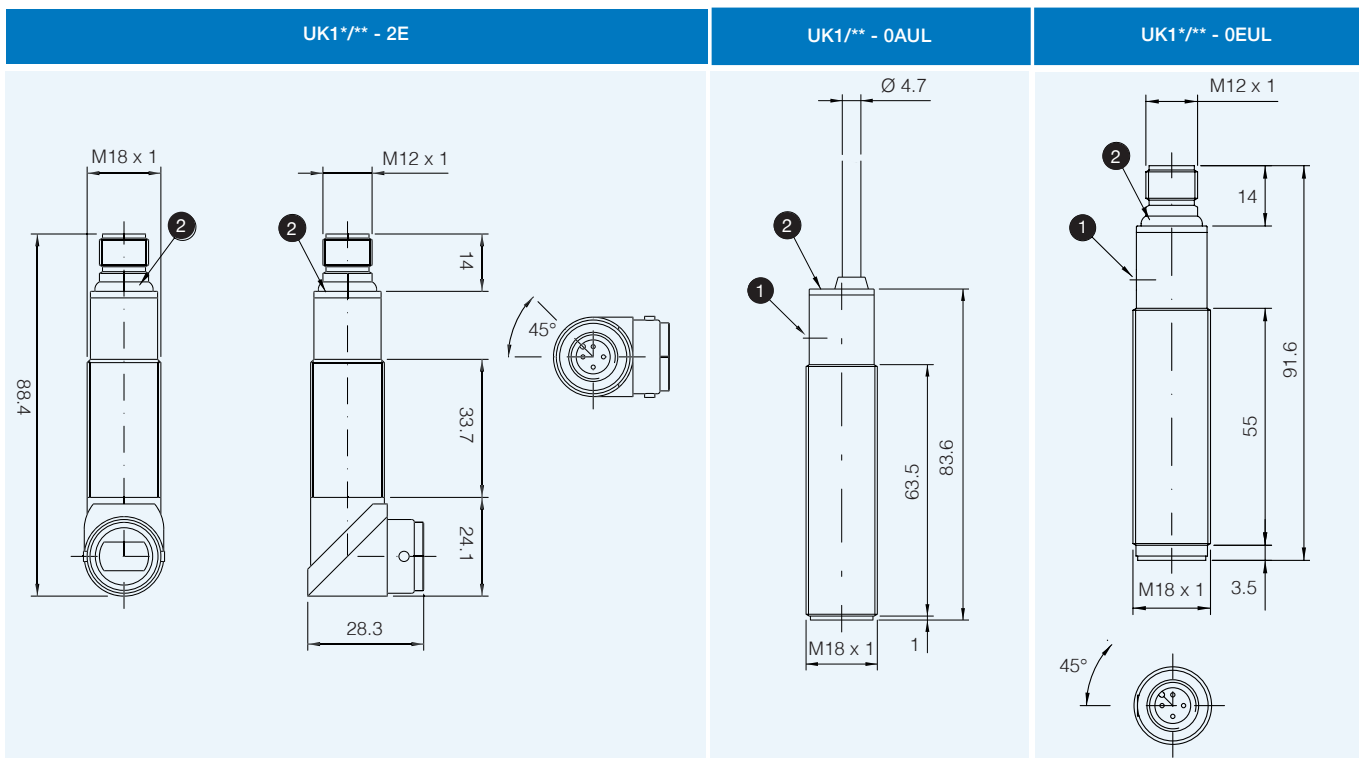

1 Teach-In button

2 LED

UK1 - UKR1



## dimensions (mm)

accessories included in all plastic models

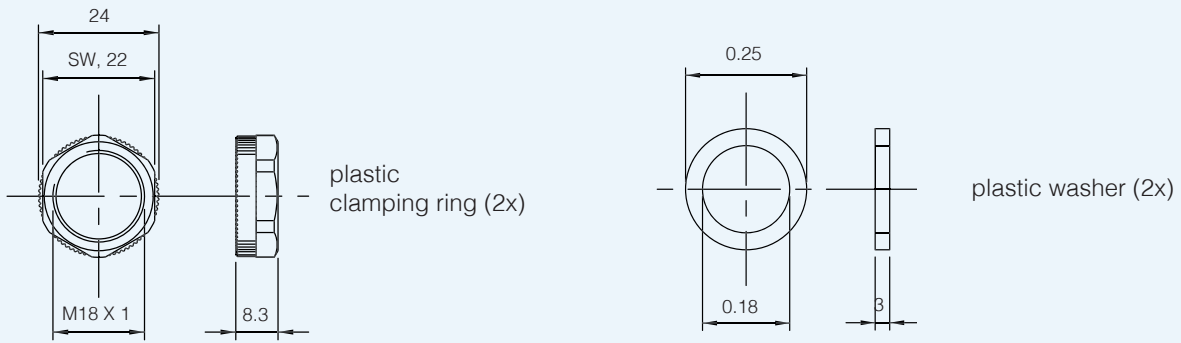

M18 with  
Teach-In button

## dimensions (mm)

metallic models

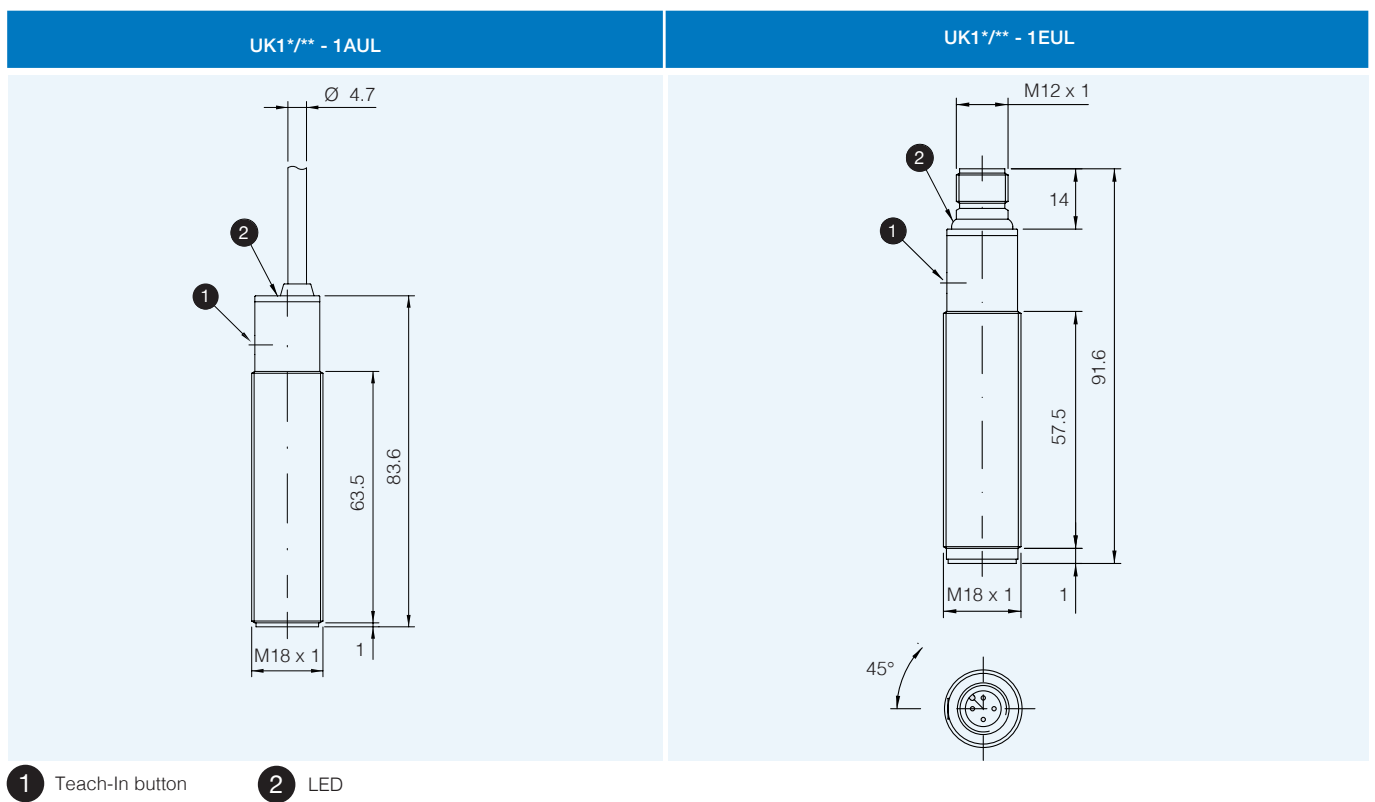

## dimensions (mm)

accessories included in all metallic models

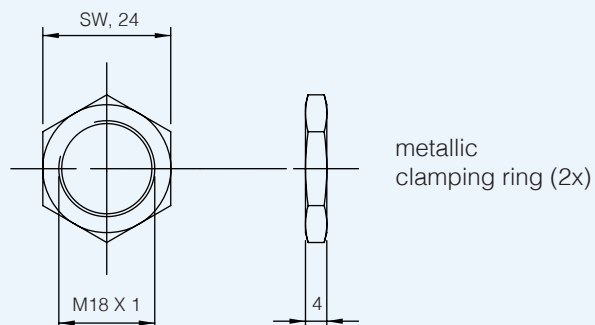

UK1 - UKR1



# UK6 series

M18 cylindrical short body direct diffuse & retro-reflective Ultrasonic Sensor UK6 with Teach-In button



## features

- M18 diffuse sensors with short housing
- Digital output
- Analogue output

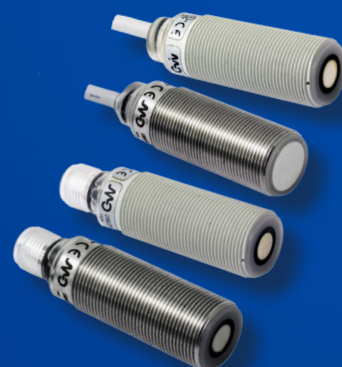

M18 short body with Teach-In button

## web contents



- Application notes
- Photos
- Catalogue / Manuals



## code description

UK 6 A / H 1 - 0 E UL AN

series	<b>UK</b>	M18 Ultrasonic sensor
function	<b>[ ]</b>	Diffuse models
	<b>R</b>	Retroreflective models
housing type	<b>6</b>	M18 Short housing
nominal sensing distance Sn	<b>A</b>	40...300 mm (diffuse models), 50...300 mm (retroreflective models)
	<b>C</b>	60...800 mm (diffuse models), 80...800 mm (retroreflective models)
	<b>D</b>	80...1,200 mm (diffuse models), 100...1,200 mm (retroreflective models)
adjustment	<b>H</b>	Teach-In by cable
output	<b>1</b>	0...10 V single voltage analogue output
	<b>2</b>	4...20 mA single current analogue output
	<b>P</b>	PNP - NO/NC digital output
	<b>N</b>	NPN - NO/NC digital output
housing materials	<b>0</b>	Axial plastic housing
	<b>1</b>	AISI 316L (DIN 1.4404) stainless steel housing (axial)
cable exit / connector	<b>E</b>	M12 plug cable exit
	<b>A</b>	2 m cable exit
cULus	<b>UL</b>	cULus certified
ATEX	<b>AN</b>	ATEX certified, Cat.3, 2.22 Zone





## available models

### diffuse models

M18 short body  
with Teach-In button

housing	material	output	distance (mm)	PNP - NO/NC	NPN - NO/NC	analogue output 0...10 V	analogue output 4...20 mA
M18	plastic	M12	40...300	UK6A/HP-0EUL	UK6A/HN-0EUL	UK6A/H1-0EUL	UK6A/H2-0EUL
			60...800	UK6C/HP-0EUL	UK6C/HN-0EUL	UK6C/H1-0EUL	UK6C/H2-0EUL
			80...1,200	UK6D/HP-0EUL	UK6D/HN-0EUL	UK6D/H1-0EUL	UK6D/H2-0EUL
		cable	40...300	UK6A/HP-0AUL	UK6A/HN-0AUL	UK6A/H1-0AUL	UK6A/H2-0AUL
			60...800	UK6C/HP-0AUL	UK6C/HN-0AUL	UK6C/H1-0AUL	UK6C/H2-0AUL
			80...1,200	UK6D/HP-0AUL	UK6D/HN-0AUL	UK6D/H1-0AUL	UK6D/H2-0AUL



housing	material	output	distance (mm)	PNP - NO	NO/NC	analogue output 0...10 V	analogue output 4...20 mA
M18	metal	M12	40...300	UK6A/HP-1EUL	UK6A/HN-1EUL	UK6A/H1-1EUL	UK6A/H2-1EUL
			60...800	UK6C/HP-1EUL	UK6C/HN-1EUL	UK6C/H1-1EUL	UK6C/H2-1EUL
			80...1,200	UK6D/HP-1EUL	UK6D/HN-1EUL	UK6D/H1-1EUL	UK6D/H2-1EUL
		cable	40...300	UK6A/HP-1AUL	UK6A/HN-1AUL	UK6A/H1-1AUL	UK6A/H2-1AUL
			60...800	UK6C/HP-1AUL	UK6C/HN-1AUL	UK6C/H1-1AUL	UK6C/H2-1AUL
			80...1,200	UK6D/HP-1AUL	UK6D/HN-1AUL	UK6D/H1-1AUL	UK6D/H2-1AUL

## available models

### retroreflective models

housing	material	distance (mm)	plastic housing		metal housing	
			PNP - NO/NC	NPN - NO/NC	PNP - NO/NC	NPN - NO/NC
M18	M12	50...300	UKR6A/HP-0EUL	UKR6A/HN-0EUL	UKR6A/HP-1EUL	UKR6A/HN-1EUL
		80...800	UKR6C/HP-0EUL	UKR6C/HN-0EUL	UKR6C/HP-1EUL	UKR6C/HN-1EUL
		100...1,200	UKR6D/HP-0EUL	UKR6D/HN-0EUL	UKR6D/HP-1EUL	UKR6D/HN-1EUL
	cable	50...300	UKR6A/HP-0AUL	UKR6A/HN-0AUL	UKR6A/HP-1AUL	UKR6A/HN-1AUL
		80...800	UKR6C/HP-0AUL	UKR6C/HN-0AUL	UKR6C/HP-1AUL	UKR6C/HN-1AUL
		100...1,200	UKR6D/HP-0AUL	UKR6D/HN-0AUL	UKR6D/HP-1AUL	UKR6D/HN-1AUL



	UK6A/H*-**	UK6C/H*-**	UK6D/H*-**
			
nominal sensing distance	300 mm	800 mm	1.200 mm
minimum sensing distance	40 mm	60 mm	80 mm
beam angle	7° ± 2°	8° ± 2°	
switching frequency	8 Hz	5 Hz	5 Hz
operating voltage	10...30 Vdc		
max ripple content	5 %		
output type	PNP or NPN - NO/NC selectable analogue output: 0...10 V or 4...20 mA		
output current	100 mA		
output voltage drop	≤ 2,2 V (@ I = 100 mA)		
no-load supply current	≤ 35 mA @ Val = 30 V		
leakage current	≤ 10 µA @ 30 V		
power on delay	≤ 100 ms		
temperature range	-20°C...+70°C		
temperature drift of Sr	≤ 5 %		
short-circuit protection	● (autoreset)		
induction protection	●		
voltage reversal protection	●		
weight	plastic version: 65 g connector / 75 g cable metallic housing: 80 g connector / 140 g cable		
LEDs	yellow: output green: alignment		
protection degree	IP67		
EMC	IEC60947-5-2		
housing material	plastic housing: PTB metal housing: AISI316L		
active head material	epoxy - glass resin		
connection	M12 plug cable exit 2 m cable exit		

<sup>(1)</sup> metallic target 100 x 100 (UK6A)

<sup>(2)</sup> metallic target 200 x 200 (UK6C - UK6D)



# technical specification

M18 short body  
with Teach-In button

	UK6RA/H*~**	UKR6C/H*~**	UKR6D/H*~**
nominal sensing distance	300 mm	800 mm	1,200 mm
detection distance Sr	270 mm	720 mm	1,080 mm
minimum distance from background	50 mm	80 mm	100 mm
beam angle	7° ± 2°	8° ± 2°	
switching frequency	8 Hz	5 Hz	3 Hz
operating voltage	10...30 Vdc		
max ripple content	5 %		
output type	PNP or NPN - NO/NC selectable		
output current	100 mA		
output voltage drop	≤ 2,2 V (@ I = 100mA)		
no-load supply current	≤ 35 mA @ Val = 30 V		
leakage current	≤ 10 µA @ 30 V		
power on delay	≤ 100 ms		
temperature range	-20°C...+70°C		
temperature drift of Sr	≤ 5 %		
short-circuit protection	● (autoreset)		
induction protection	●		
voltage reversal protection	●		
weight	65 g plastic version / 80 g metallic version		
LEDs	yellow: output green: alignment		
protection degree	IP67		
EMC	IEC60947-5-2		
housing material	plastic housing: PTB metal housing: AISI316L		
active head material	epoxy - glass resin		
connection	M12 plug cable exit 2 m cable exit		

# electrical diagrams of connections

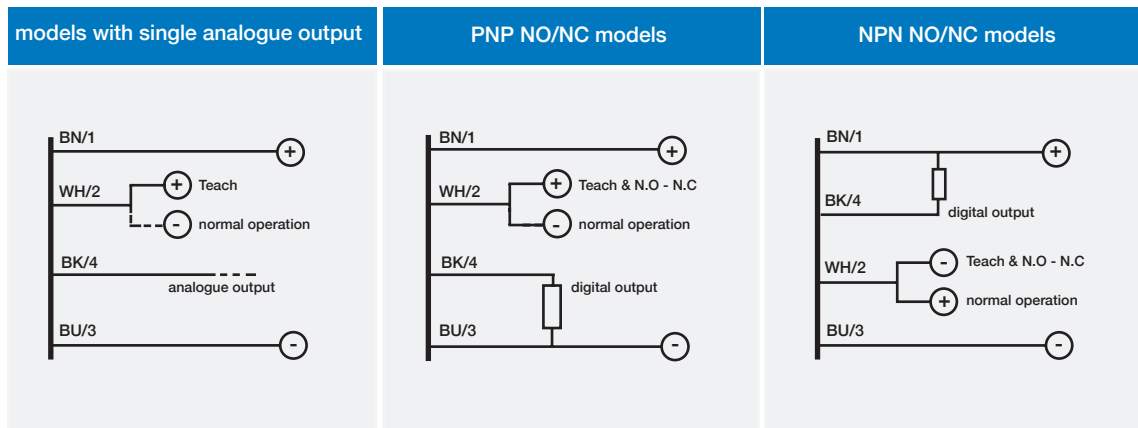

- BN** brown
- BU** blu
- BK** black
- WH** white

M18 short body with Teach-In button

## connector

### M12 UK6\*\*/\*\*\_\*\*

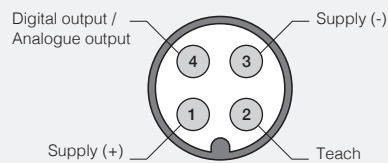

## available outputs

### models with single digital output

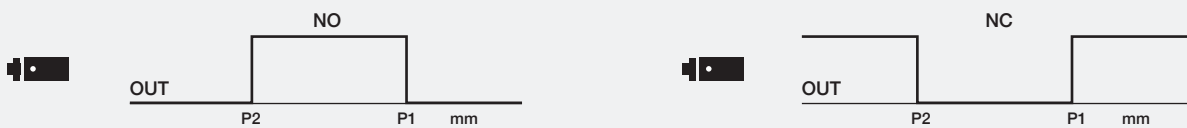

### models with single analogue output

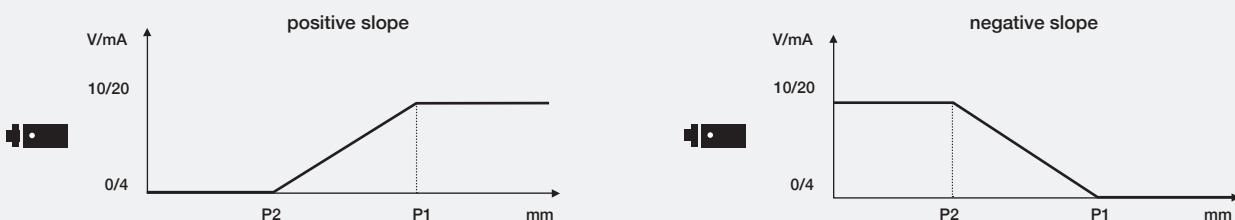

UK6 - UKR6



# response diagrams

direct diffuse models

M18 short body  
with Teach-In button

UK6A/\*\*-\*\* parallel displacement

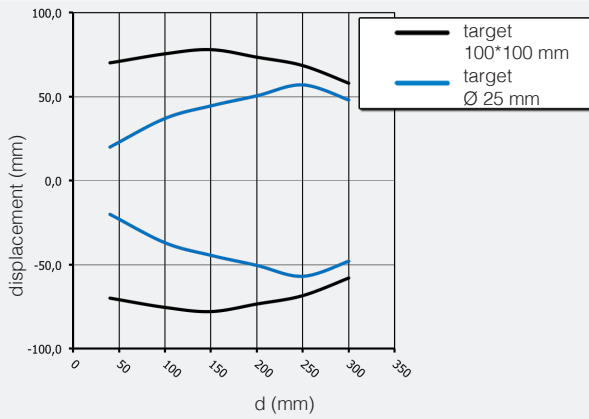

UK6C/\*\*-\*\* parallel displacement

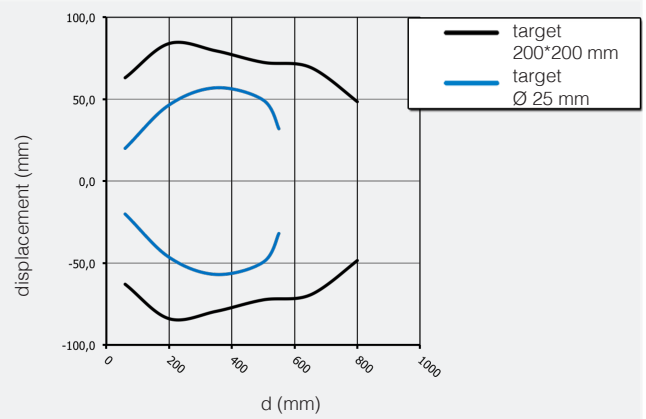

UK6D/\*\*-\*\* parallel displacement

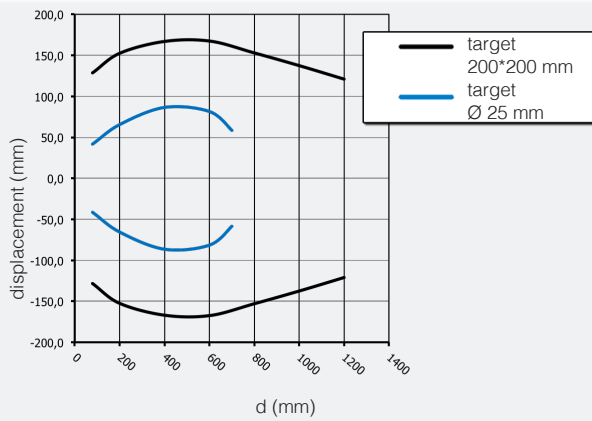

# response diagrams

retro-reflective models



M18 short body  
with Teach-In button

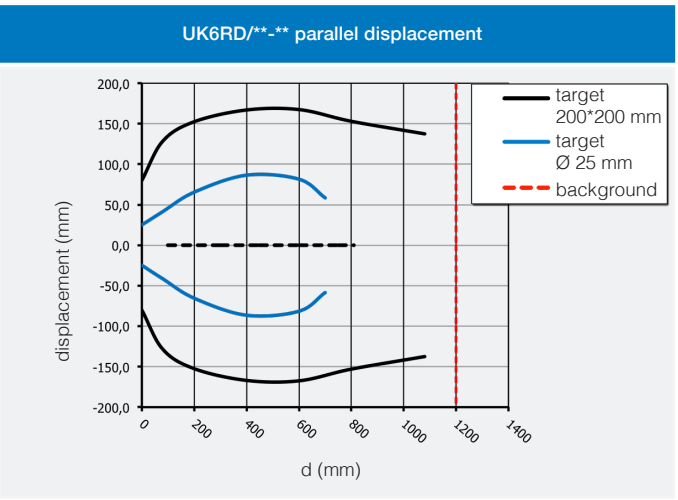
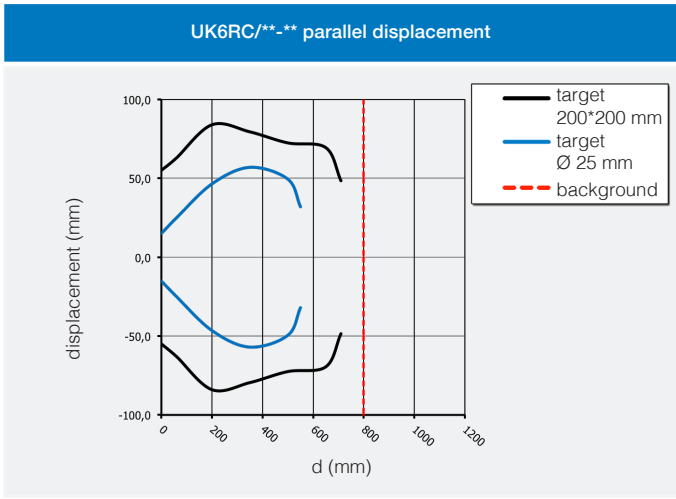
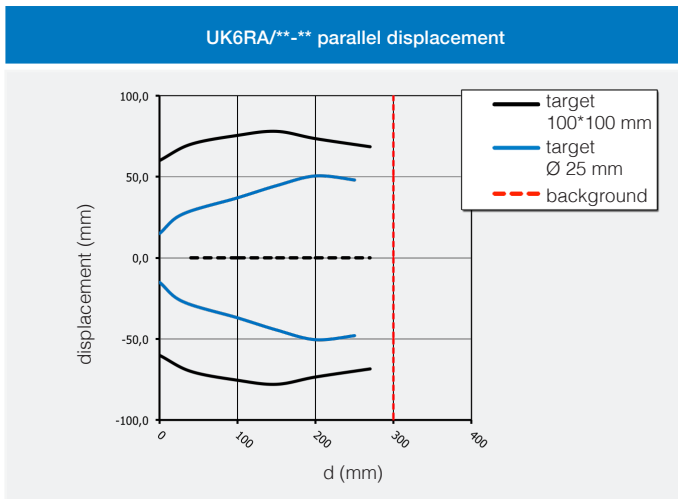

## adjustment

### Reflector detection (Sd)

Install the sensor in the correct position. Install the background (any solid, flat, fixed surface) perpendicularly to the sensor's axes. Connect the Teach-in wire to +24V (PNP models) or to 0V (NPN models) for 2 sec. Yellow LED blinks for 5 times, after that, the sensor acquires the background position (Sd distance).

### NO/NC selection

Connect the Teach-in wire to +24V (PNP models) or to 0V (NPN models) for a time > 8 sec. Yellow LED blinks quickly until the teach-in wire is released, then 5 blinks confirm the change of working state. The sensor change its working mode from NO to NC and vice versa.

### Operating distance (Sr)

The effective operating distance (Sr) is equivalent to background distance (Sd) decreases of 10%. This hysteresis allows the correct detection of the target even if the background is vibrating during the machine normal operations.



## dimensions (mm)

M18 short body  
with Teach-In button

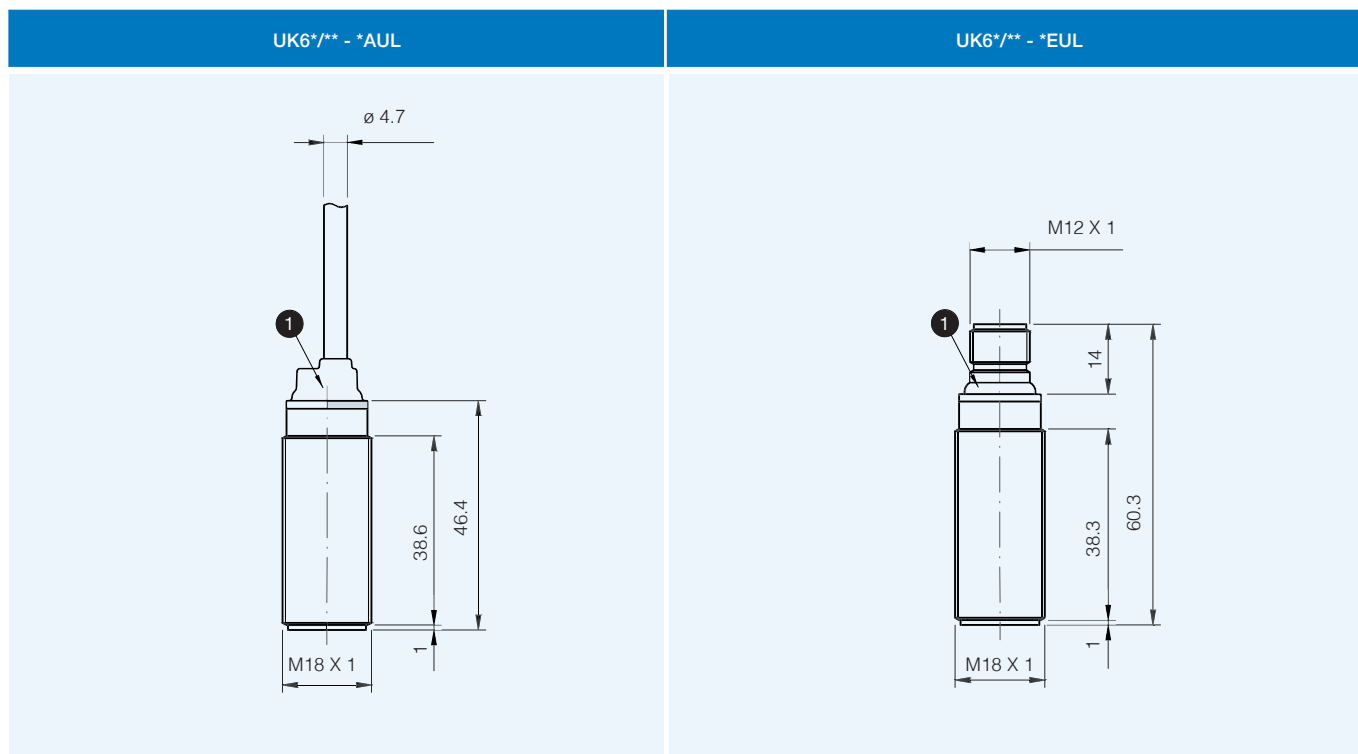

1 LED

## dimensions (mm)

accessories included in all plastic models

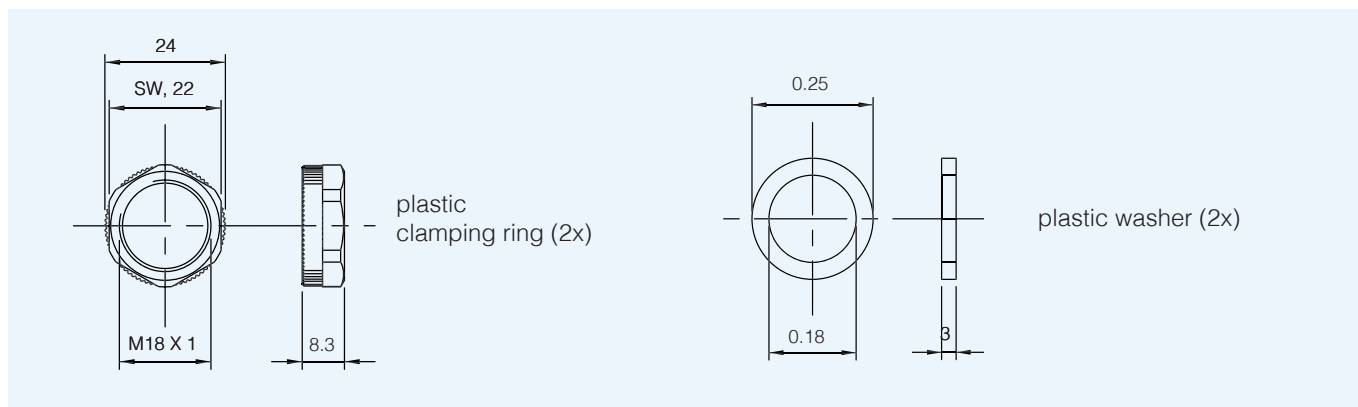

## dimensions (mm)

accessories included in all metallic models

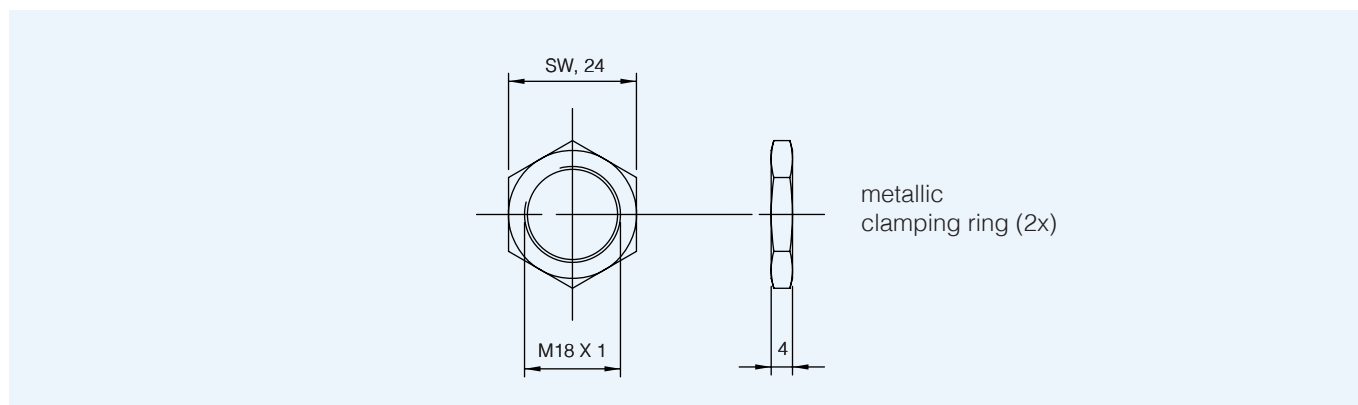

UK6 - UKR6



# UT and UTR series

M30 cylindrical direct diffuse & retro-reflective Ultrasonic Sensor with Teach-In button



M30 with Teach-In button

## features

- M30 ultrasonic sensor with standard housing and with large front with high performances and high sensing distances
- Adjustable hysteresis function: models with double digital programmable output specific for level detection
- Models with voltage or current output: programmable slope to optimize resolution
- Adjustable working area (window mode or object mode) by Teach-in button on all models for a quick and easy installation
- Two multifunction LEDs: orange LED for adjustment procedure and output type and green LED for target alignment
- Plastic and AISI 316L stainless steel housing, plug M12 or cable exit 4 pin

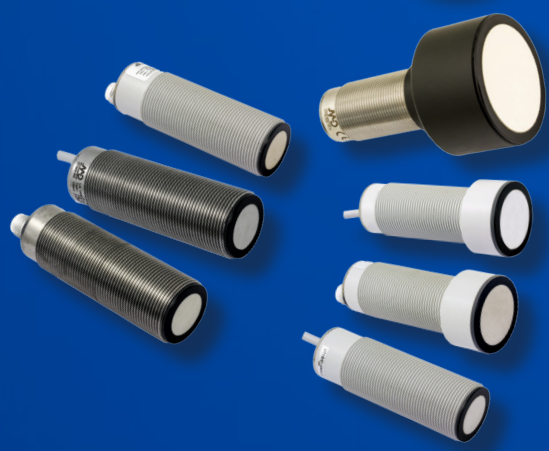

## web contents



- Application notes
- Photos
- Catalogue / Manuals



## code description<sup>(\*)</sup>

UT 1 B / E 1 - 0 E 1 I UL

series	UT	M30 Ultrasonic Sensor
function		Direct diffuse models
	R	Retroreflective models
housing type	1	Standard housing
	2	Large front transducer, Ø 38.8 mm
	5	Large front transducer Ø 61 mm
nominal sensing distance Sn	B	250 - 3,500 mm direct diffuse/350 - 3,500 metallic housing
	F	350 - 6,000 mm direct diffuse
	L	600 - 8,000 mm direct diffuse
adjustment	E	Sensitivity adjustment and NO/NC selection by Teach-in button
output	1	0...10 V single voltage analogue output
	2	4...20 mA single current analogue output
	P	PNP - NO/NC digital output
	N	NPN - NO/NC digital output
	W	PNP two digital outputs with standard window and adjustable hysteresis functions
	M	NPN two digital outputs with standard window and adjustable hysteresis functions
	6	PNP - NO/NC digital output + 4 ... 20 mA current analogue output
	4	NPN - NO/NC digital output + 4 ... 20 mA current analogue output
	7	PNP - NO/NC digital output + 0 ... 10 V voltage analogue output
9	NPN - NO/NC digital output + 0 ... 10 V voltage analogue output	
housing materials	0	Axial plastic housing
	1	Axial AISI 316L (DIN 1.4404) stainless steel housing
cable exit / connector	E	M12 plug cable exit
	A	2 m cable exit
transducer material	1I	Plastic transducer
cULus	UL	With cULus certification

UT - UTR





## available models

cULus certified - Single digital or analogue output

housing	distance (mm)	output	analogue output 0...10 V	analogue output 4...20 mA	1 x PNP - NO/NC	1 x NPN - NO/NC
plastic	250...3,500	M12	UT1B/E1-0EUL	UT1B/E2-0EUL	UT1B/EP-0EUL	UT1B/EN-0EUL
		cable	UT1B/E1-0AUL	UK1B/E2-0AUL	UT1B/EP-0AUL	UT1B/EN-0AUL

## available models

cULus certified - Double digital output

housing	distance (mm)	output	2 X PNP (adjustable hysteresis + standard window MD)	2 X NPN (adjustable hysteresis + standard window MD)
plastic	250...3,500	M12	UT1B/EW-0EUL	UT1B/EM-0EUL
		cable	UT1B/EW-0AUL	UK1B/EM-0AUL
AISI316L	350...3,500	M12	UT1B/EW-1EUL	UT1B/EM-1EUL
		cable	UT1B/EW-1AUL	UT1B/EM-1AUL
plastic	350...6,000	M12	UT2F/EW-0EUL	UT2F/EM-0EUL
		cable	UT2F/EW-0AUL	UT2F/EH-0AUL
AISI 316L housing + plastic transducer	600...8,000	M12	UT5L/EW-1E1IUL	UT5L/EM-1E1IUL
		cable	UT5L/EW-1A1IUL	UT5L/EH-1A1IUL

## available models

cULus certified - Double mixed output (digital + analogue)

housing	distance (mm)	output	1 x PNP - NO/NC + 4...20 mA	1 x NPN - NO/NC + 4...20 mA	1 x PNP - NO/NC + 0...10 V	1 x NPN - NO/NC + 0...10 V
plastico	250...3,500	M12	UT1B/E6-0EUL	UT1B/E4-0EUL	UT1B/E7-0EUL	UT1B/E9-0EUL
		cable	UT1B/E6-0AUL	UT1B/E4-0AUL	UT1B/E7-0AUL	UT1B/E9-0AUL
acciaio inox AISI 316L	350...3,500	M12	UT1B/E6-1EUL	UT1B/E4-1EUL	UT1B/E7-1EUL	UT1B/E9-1EUL
		cable	UT1B/E6-1AUL	UT1B/E4-1AUL	UT1B/E7-1AUL	UT1B/E9-1AUL
plastico	350...6,000	M12	UT2F/E6-0EUL	UT2F/E4-0EUL	UT2F/E7-0EUL	UT2F/E9-0EUL
		cable	UT2F/E6-0AUL	UT2F/E4-0AUL	UT2F/E7-0AUL	UT2F/E9-0AUL
AISI 316L housing + plastic transducer	600...8,000	M12	UT5L/E6-1E1IUL	UT5L/E4-1E1IUL	UT5L/E7-1E1IUL	UT5L/E9-1E1IUL
		cable	UT5L/E6-1A1IUL	UT5L/E4-1A1IUL	UT5L/E7-1A1IUL	UT5L/E9-1A1IUL



	UT1B/E*-**UL	UT2F/E*-0*UL	UT5L/E*-1*1LUL
maximum sensing distance	3,500 mm <sup>(1)</sup>	6,000 mm <sup>(2)</sup>	8,000 mm <sup>(2)</sup>
minimum sensing distance	250 mm / 350 mm metallic housing	350 mm	600 mm
sensing range (Sd)	250...3,500 mm (plastic) / 350...3,500 mm (metallic)	350...6,000 mm	600...8,000 mm
beam angle	± 7°	± 9°	15° ± 1°
switching frequency (digital output)	2 Hz / 1 Hz metallic housing	1 Hz	
response time (digital output)	250 ms	500 ms	
response time (analogue output)	600 ms	600 ms	
hysteresis	1 % off full scale value		
repeatability	1 % off full scale value	0.5 % off full scale value	1 % off full scale value
resolution	4 mm	6 mm	10 mm
linearity error	1 % off full scale value		
temperature range	- 20°C...+ 70°C		
temperature compensation	●		
operating voltage	12 - 30 Vcc; 15 - 30 Vcc: for model with analog voltage output (0 - 10 V)		
temperature drift	± 8 % (digital output); ± 5 % (analogue output)		
ripple	5 %		
leakage current	≤ 10 µA @ 30 Vcc		
output voltage drop	2.2 V max. (IL = 100 mA)		
no-load supply current	≤ 50 mA		
output current (digital output)	100 mA		
minimum load resistance (analog voltage output)	3 k Ω		
set point adjustment	Teach-In button		
power on delay	≤ 500 ms (digital output)		
power on delay	≤ 900 ms (analogue output)		
power supply protections	polarity reversal, transient		
digital output electrical protection	short circuit (auto reset), overvoltage pulses		
analog output electrical protections	overvoltage pulses		
EMC	conforming to EMC Directive, according to EN 60947-5-2		
protection degree	IP67 (EN60529); NEMA 4X <sup>(3)</sup>	IP67 (EN 60529) <sup>(3)</sup>	
housing material	PBT/AISI 316L	PBT	AISI 316L + PBT
active head material	epoxy-glass resin AISI 316L + PBT		
tightening torque	1.5 Nm (plastic housing) / 100 Nm plastic version: 140 g connector / 200 g cable metallic version: 215 g connector / 220	1.5 Nm	100 Nm (metallic housing)
weight		170 g connector / 300 g cable	
storage temperature	- 35°C...+ 70° without freeze		

<sup>(1)</sup> Metallic target 200 x 200 mm <sup>(2)</sup> Metallic target 400 x 400 <sup>(3)</sup> Protection guarantee only with plug cable well mounted





## available models

retroreflective models M30

housing	function	portata (mm)	output	PNP - NO/NC	NPN - NO/NC
plastic	retroreflective	250...3,500	M12	UTR1B/EP-0EUL	UTR1B/EN-0EUL
		350...6,000		UTR2F/EP-0EUL	UTR2F/EN-0EUL
		250...3,500	cable	UTR1B/EP-0AUL	UTR1B/EN-0AUL
		350...6,000		UTR2F/EP-0AUL	UTR2F/EN-0AUL

## technical specification (cULus certified)

	UTR1B/E*-0*	UTR2F/E*-0*
		
nominal sensing distance $S_n$	3,500 mm <sup>(1)</sup>	6,000 mm <sup>(2)</sup>
reflector minimum sensing distance	250 mm	350 mm
beam angle	$\pm 7^\circ$	$\pm 8^\circ$
switching frequency	1 Hz	1 Hz
operating voltage	15 - 30 Vdc	
max. ripple content	5 %	
output type	PNP o NPN NO/NC selectable	
output current	100 mA	
output voltage drop	$\leq 2.2 \text{ V (@ } I = 100\text{mA)}$	
no-load supply current	$\leq 50 \text{ mA @ } V_{al}=24\text{V}$	
leakage current	$\leq 10 \mu\text{A @ } 30\text{V}$	
power on delay	$\leq 500 \text{ ms}$	
temperature range	$-20^\circ\text{C} \dots +70^\circ\text{C}$	
temperature drift of $S_r$	$\leq 5 \%$	
short-circuit protection	● (autoreset)	
induction protection	●	
voltage reversal protection	●	
LEDs	yellow: output green: alignment	
protection degree	IP67	
EMC	conforming to EMC Directive according to EN 60947-5-2	
housing material	PBT	
active head material	epoxy glass resin	
connection	M12 plug cable exit, 2 m cable exit	

<sup>(1)</sup> Metallic target 200 x 200 mm <sup>(2)</sup> Metallic target 400 x 400 mm <sup>(3)</sup> Protection granted only by plug mounted in a correct way

# electrical diagrams of connections



M30 with Teach-In button

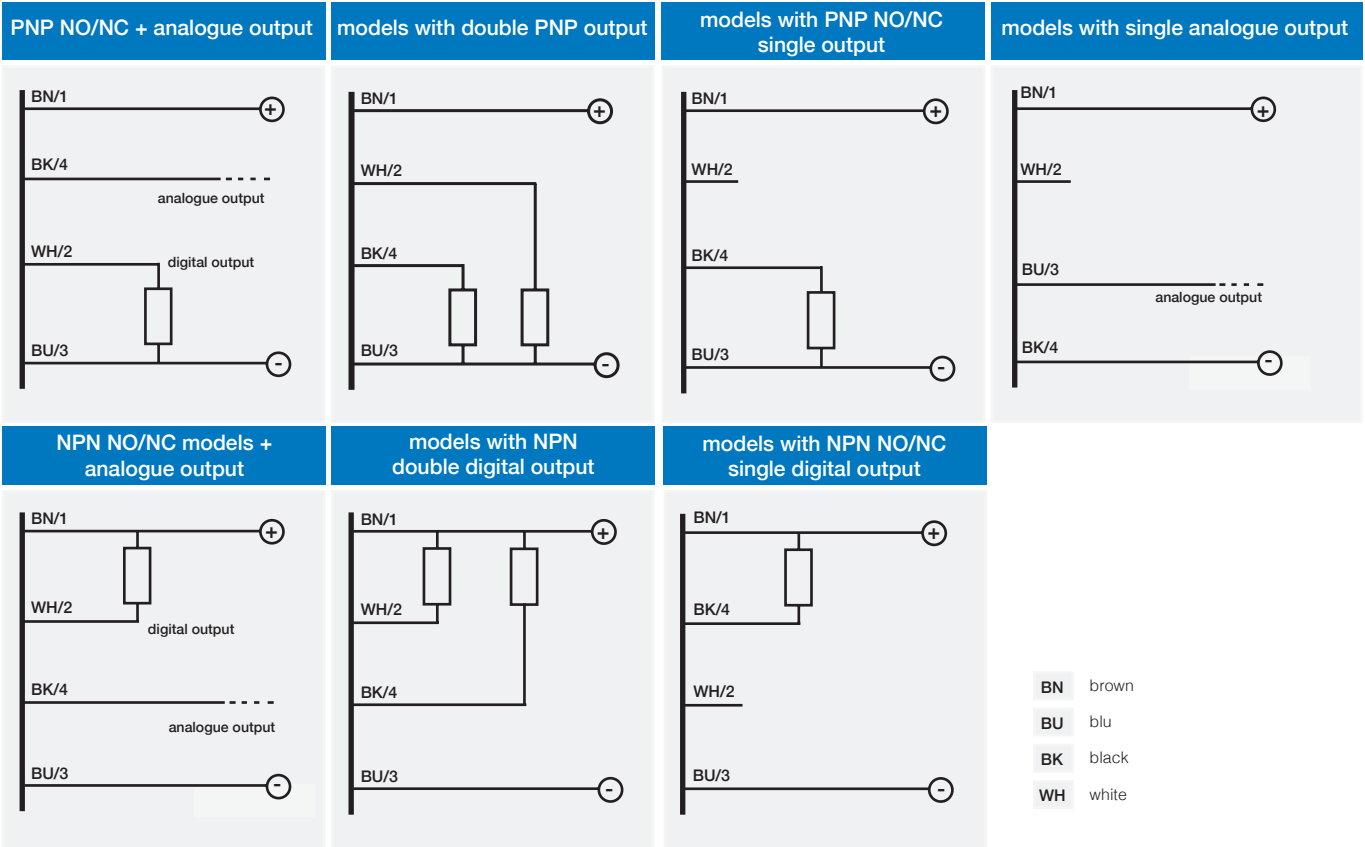

# plugs

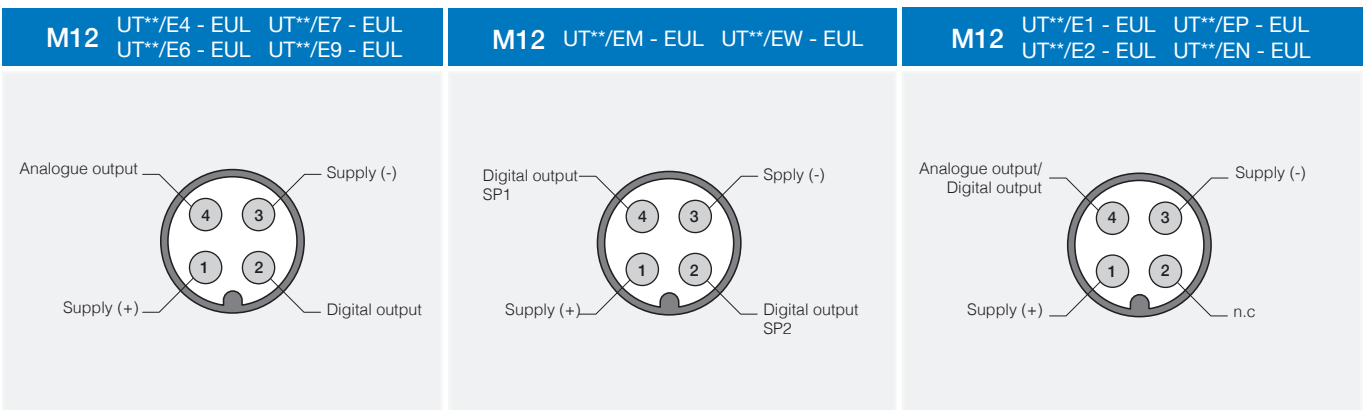



# response diagrams

direct diffuse models

parallel displacement UT1B/\*\*-\*\*

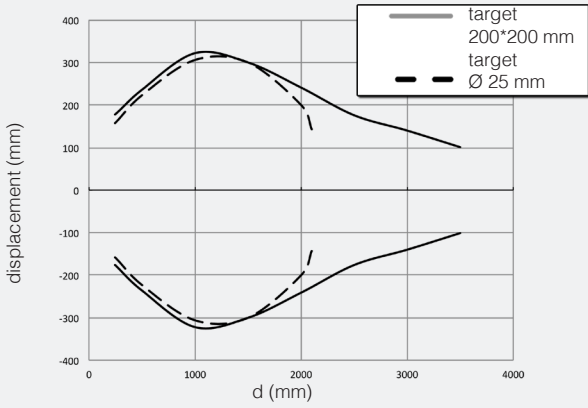

parallel displacement UT2F/\*\*-\*\*

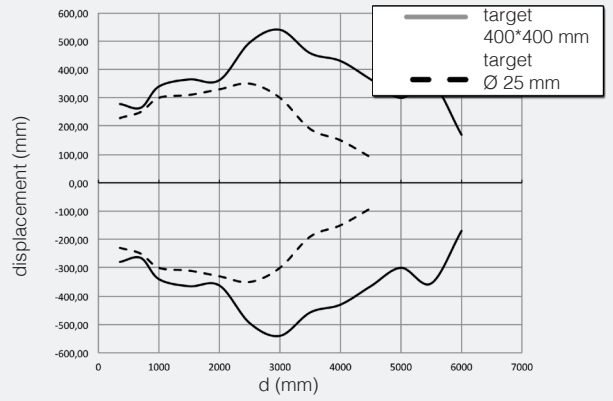

parallel displacement UT5L/\*\*-\*\*

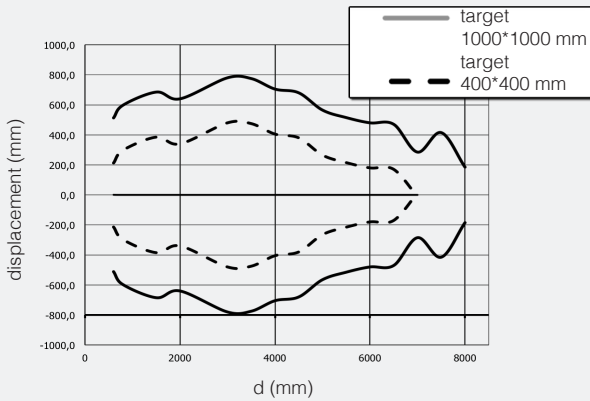

# response diagrams

retroreflective models

parallel displacement UTR1B/\*\*-\*\*

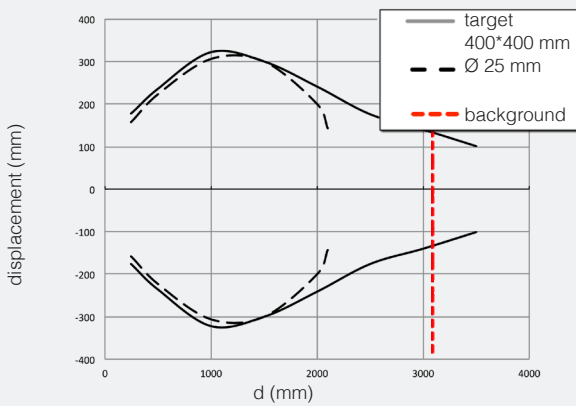

parallel displacement UTR2F/\*\*-\*\*

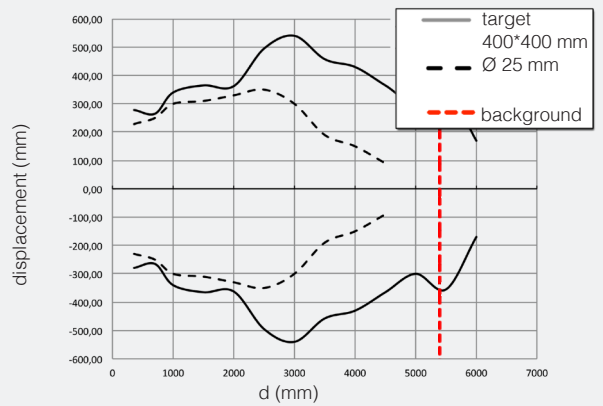

models with single digital output



models with single analogue output

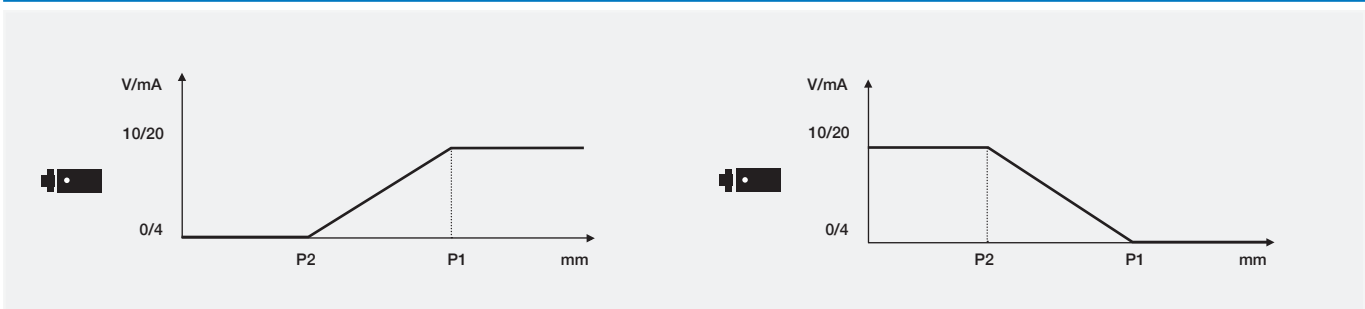

models with digital output + analogue output <sup>(1)</sup>

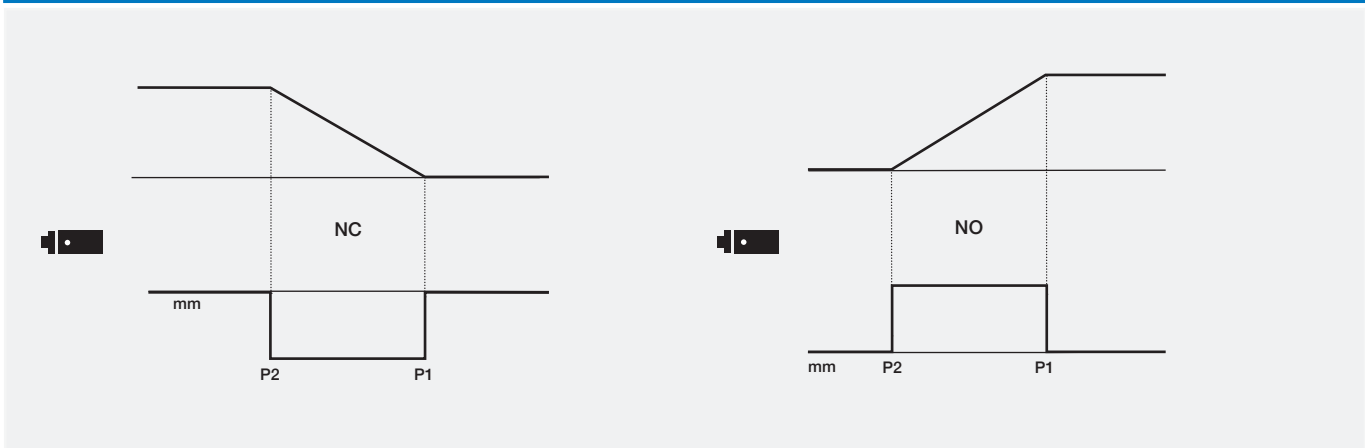

models with double output, hysteresis + standard window <sup>(2)</sup>

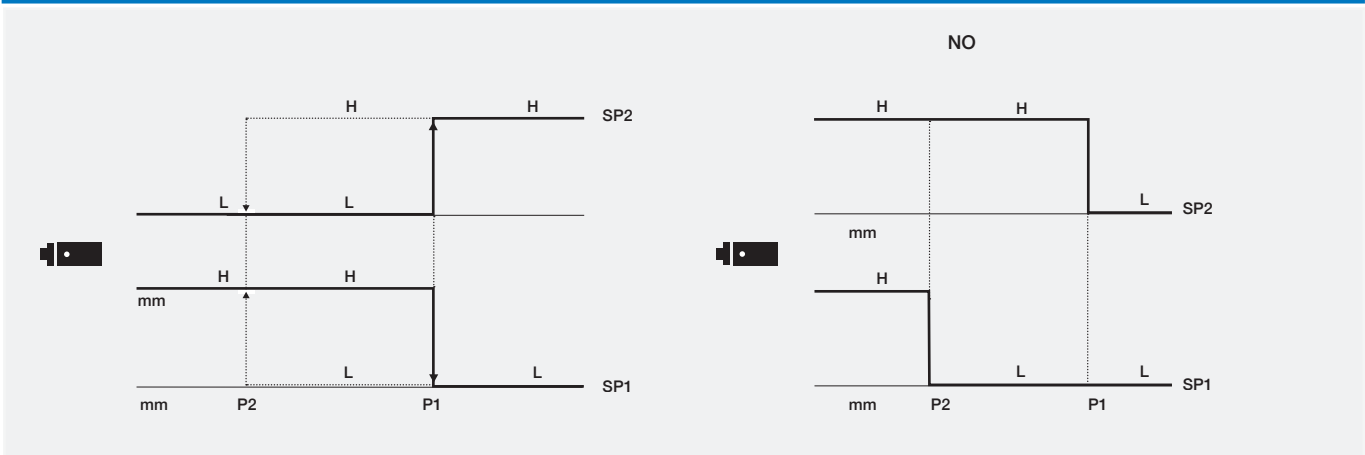

<sup>(1)</sup> Suitable, also, as single model output.

<sup>(2)</sup> In the double digital output model with the standard window and adjustable hysteresis functions if the target is removed from sensor detection range, the output type switches. These models are not forseen with NO/NC function.

- P1** maximum selected working distance and first point to select
- P2** minimum selected working distance and second point to select



## dimensions (mm)

plastic models

## dimensions (mm)

metallic models

M30 with Teach-In button

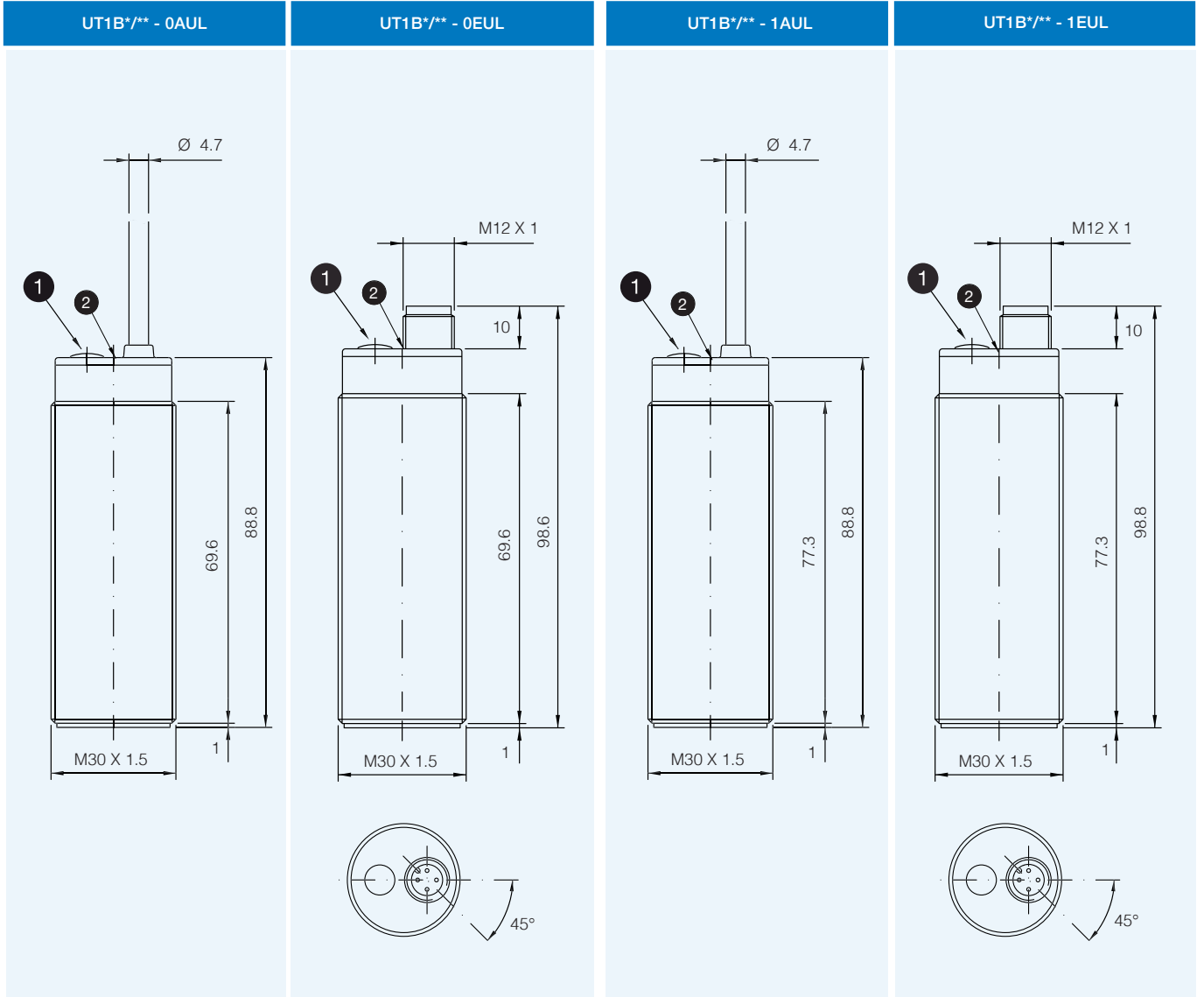

- 1 Teach-In button
- 2 LED

## dimensions (mm)

accessories included in all metallic models

## dimensions (mm)

accessories included in all metallic models

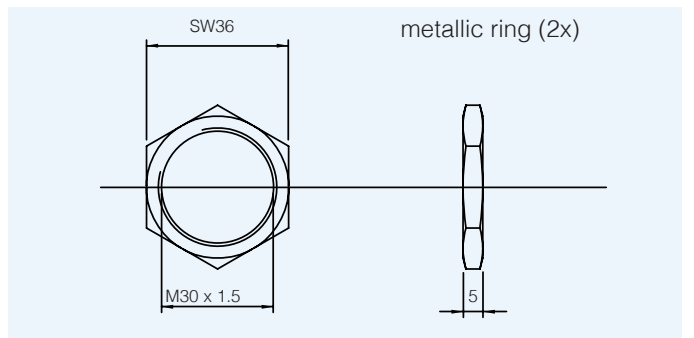
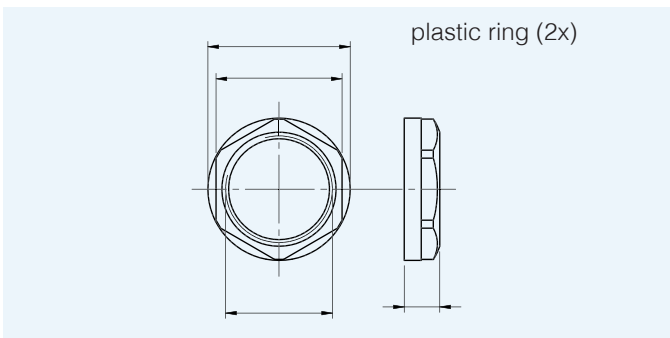

UT - UTR

## dimensions (mm)

plastic models



M30 with Teach-In button

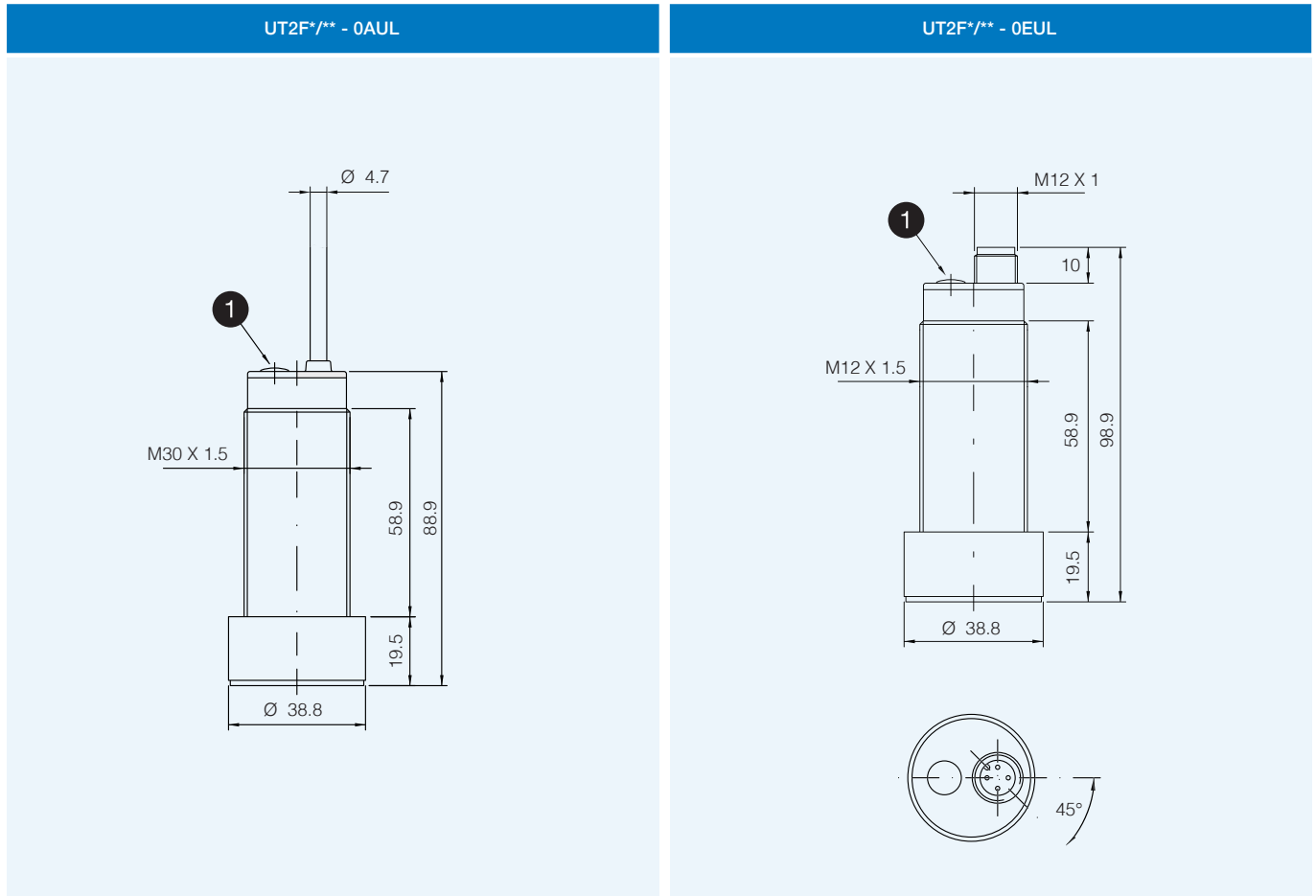

1 Teach-In button

## dimensions (mm)

accessories included in all metallic models

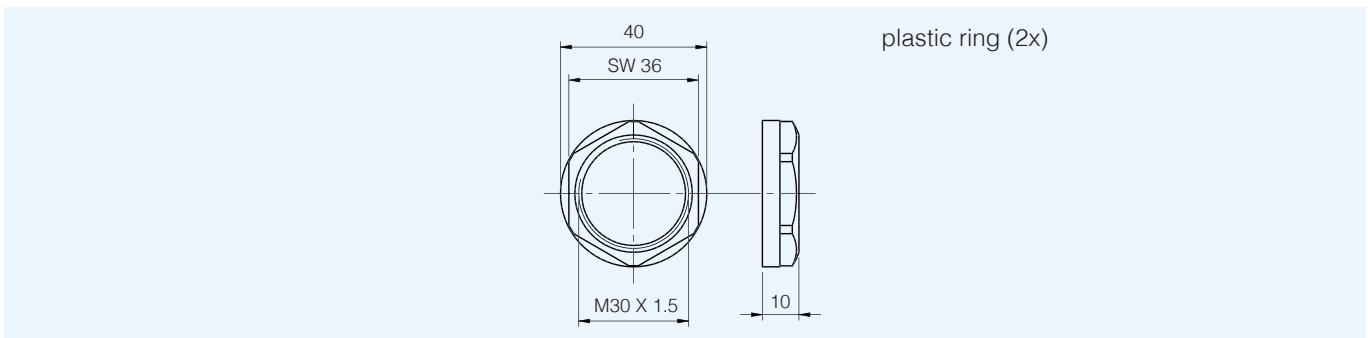



## dimensions (mm)

metallic models

M30 with Teach-In button

UT5L/\*\* - 1A1IUL

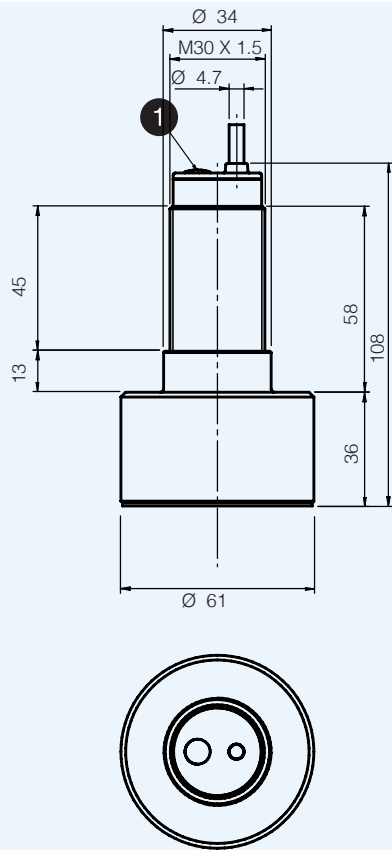

UT5L/\*\* - 1E1IUL

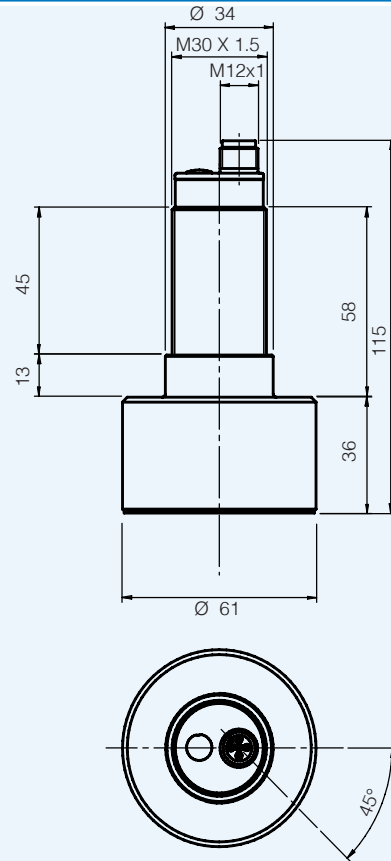

1 Teach-In button

## dimensions (mm)

accessories included in all metallic models

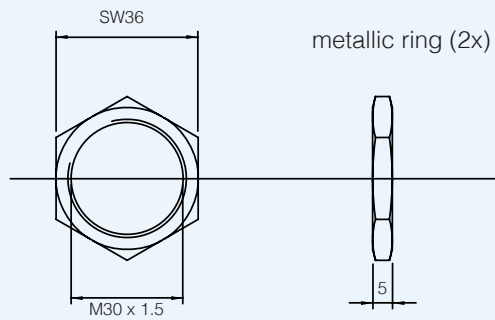



# UH series

Cubic through beam ultrasonic sensors



Cubic through beam

## features

- Total protection against any type of electric damages
- Plastic housing
- IP67 protection degree
- Approvals: CE

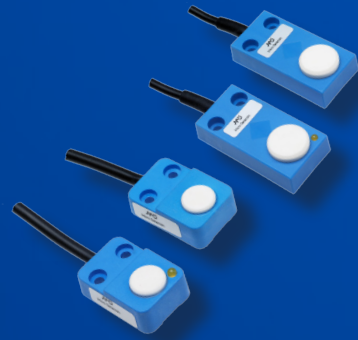

## web contents



- Application notes
- Photos
- Catalogue / Manuals



## code description

UH Z / A P - 0 A

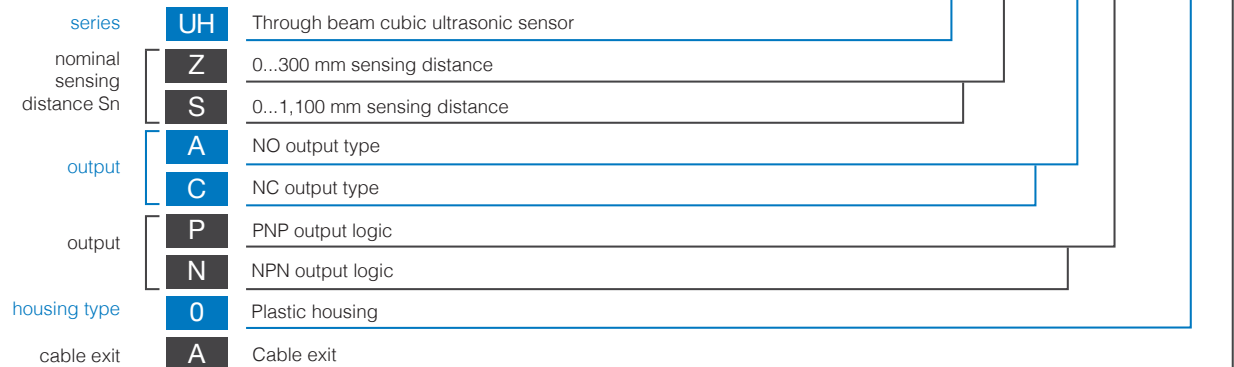

## available models

dimension	distance (mm)	output	NO - PNP	NO - NPN	NC - PNP	NC - NPN
20 x 30 x 15 mm	0...300 mm	cavo	UHZ/AP-0A	UHZ/AN-0A	UHZ/CP-0A	UHZ/CN-0A
24 x 50 x 15 mm	0...1,100 mm		UHS/AP-0A	UHS/AN-0A	UHS/CP-0A	UHS/CN-0A



	UHZ/**- 0A	UHS/**- 0A
maximum sensing distance	300 mm	1,100 mm
minimum sensing distance	0 mm	
beam angle	± 8°	± 9°
switching frequency (digital output)	500 Hz	
response time (ON/OFF)	1 ms	
emission frequency	300 kHz	180 kHz
temperature range	- 15°C...+ 60°C	
temperature compensation	●	
operating voltage	19 ... 30 Vdc	
temperature drift	-	
ripple	< 10 %	
leakage current	< 10 µA	
output voltage drop	2,5 V	
no-load supply current	40 mA	
output current	PNP o NPN - NO o NC	
minimum load resistance	< 2.5 V	
power on delay	< 200 ms	
power supply protections	polarity reversal, overvoltage pulses	
digital output protections	short circuit autoreset	
LEDs	yellow (output activated)	
EMC	conforming to EMC Directive, according to EN 60947-5-2	
protection degree	IP67 (EN60529)	
housing material	PBTP	
active head material	ceramics	
weight	100 g	150 g
storage temperature	-25°C ... +75°C	

Specifications are guaranteed only using emitter and receiver with the same serial number. Attention: do not expose sensor head to hot water ( > 50°C ) or water steam.

>

# electrical diagrams of connections



Cubic through beam

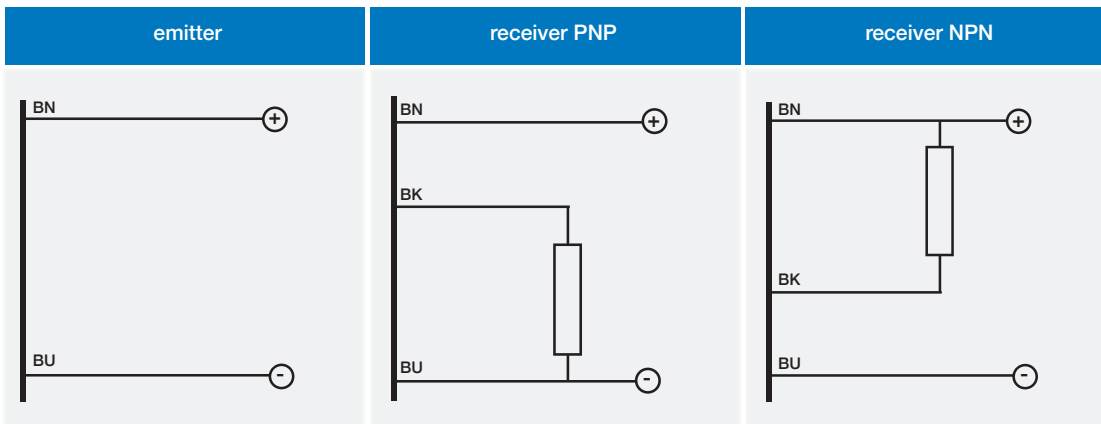

## dimensions ( mm )

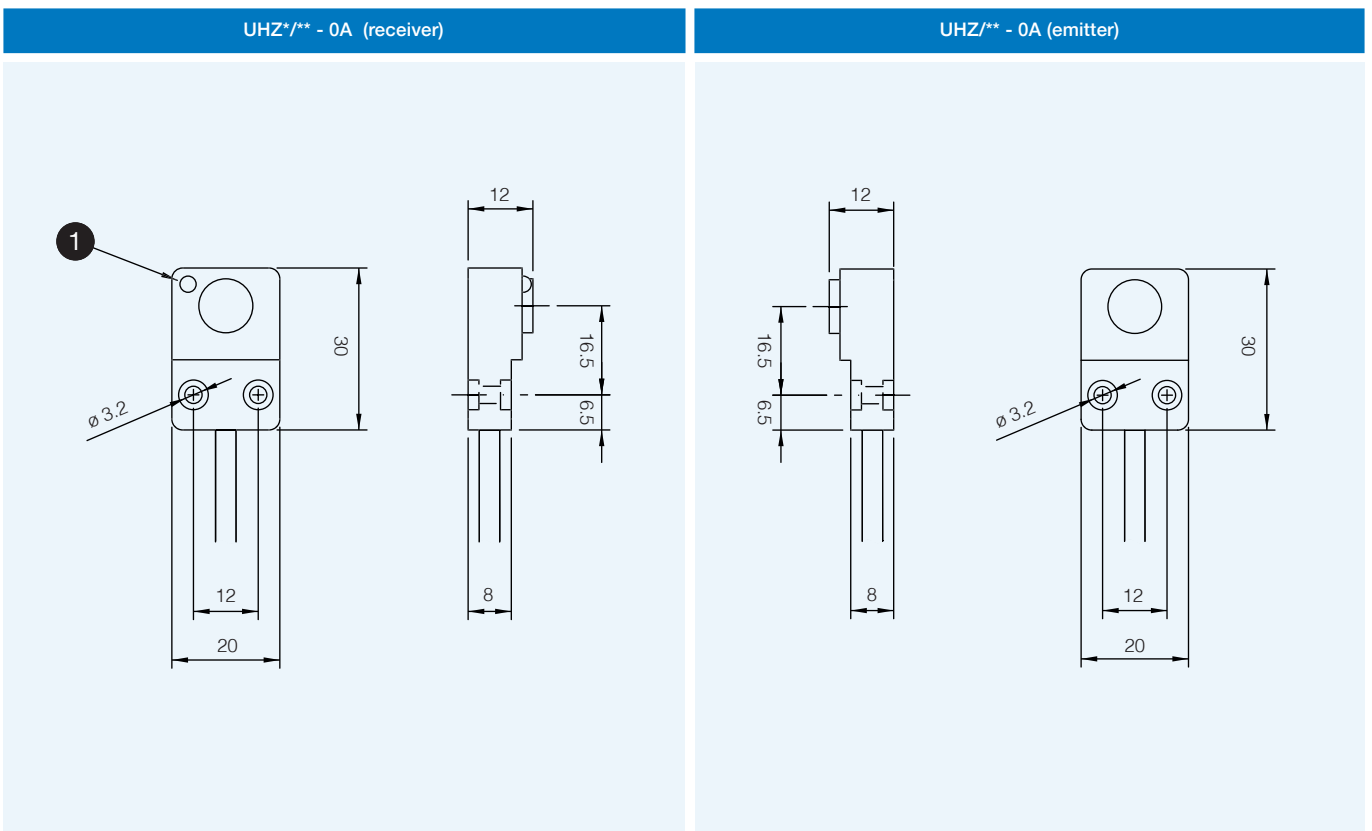

1 LED



# dimensions (mm)

Cubic through beam

UHS\*/\*\* - 0A (receiver)

UHS\*/\*\* - 0A (emitter)

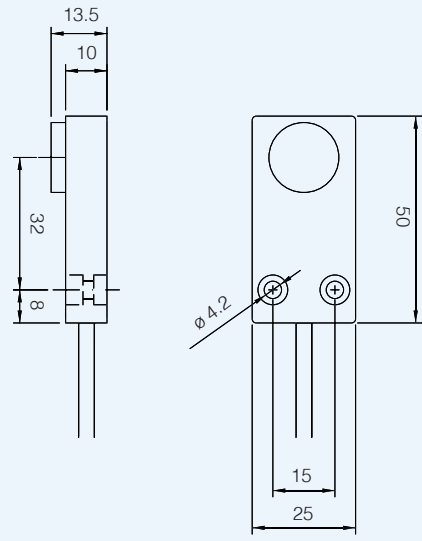
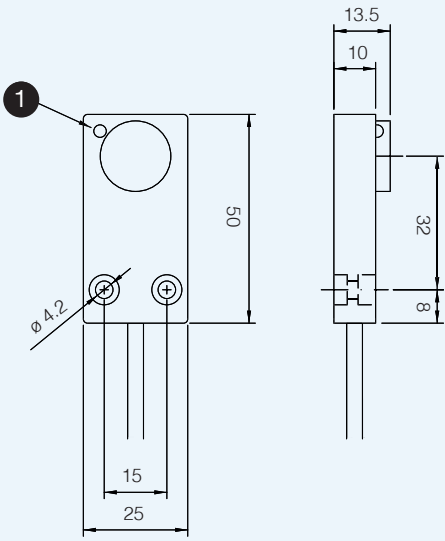

1 LED



# FC8 series

Ultrasonic fork sensors for label detection



## features

- Ultrasonic fork sensor for transparent labels, any opaque material with connector M8 4-pole
- Teach-in models with dynamic and remote teach
- Ultrasonic technology
- Small size easy to locate; aluminum case
- NPN and PNP, Lo/Do total configurable
- Width slit detection 3 mm; depth slit detection 69 mm
- Maximum switching frequency 1.500 Hz



Ultrasonic fork sensors

## web contents



- Application notes
- Photos
- Catalogue / Manuals



## code description

FC8 U / 0 P - M3 07 - 1 F

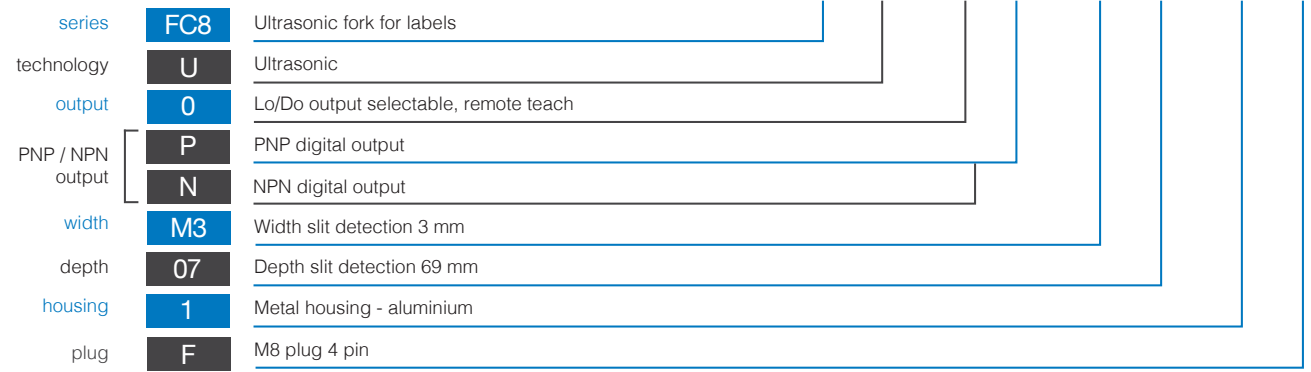

## available models

supply	installation	PNP	NPN	NPN / PNP
12...24 Vdc	M8 4 pins	FC8U/0P-M307-1F	FC8U/0N-M307-1F	FC8U/0B-M307-1F



# technical specification

## FC8U/0\*-M307-1F



nominal sensing distance	3 mm
minimum length of label	2 mm
minimum sensing distance between 2 labels	2 mm
slot depth detection	69 mm
slot length detection	-
emission	ultrasonic
maximum flow rate	180 m/min
detection accuracy	+/- 0,20 um at 120 m/min
rated operational voltage	12 ... 24 Vdc (with protection against reverse polarity)
max ripple content	10%
no-load supply current	45 mA
load current	100 mA
output voltage drop	≤ 2 V @ IL = 100 mA
switching frequency	1.500 kHz
power on delay	300 us
power supply protections	short-circuit output protected interference suppression
operation temperature range	+ 5 ... +55 °C
storage temperature	- 20 ... +70 °C
protection degree	IP65, IEC (EN60529)
housing material	painted aluminium
connection	M8 4 pins
weight approx.	160 g

## electrical diagrams of the connections

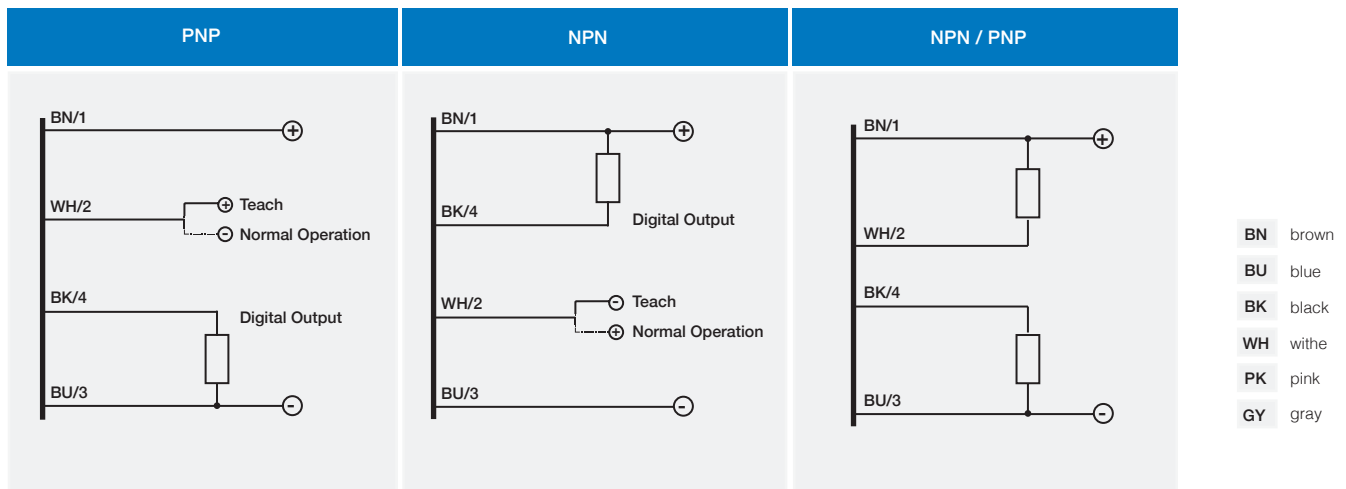

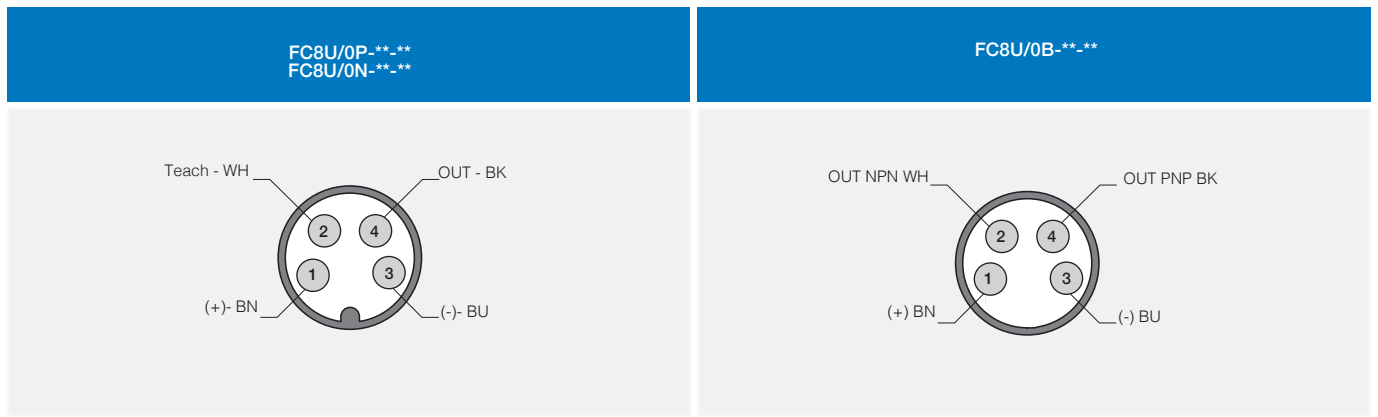

dimensions (mm)

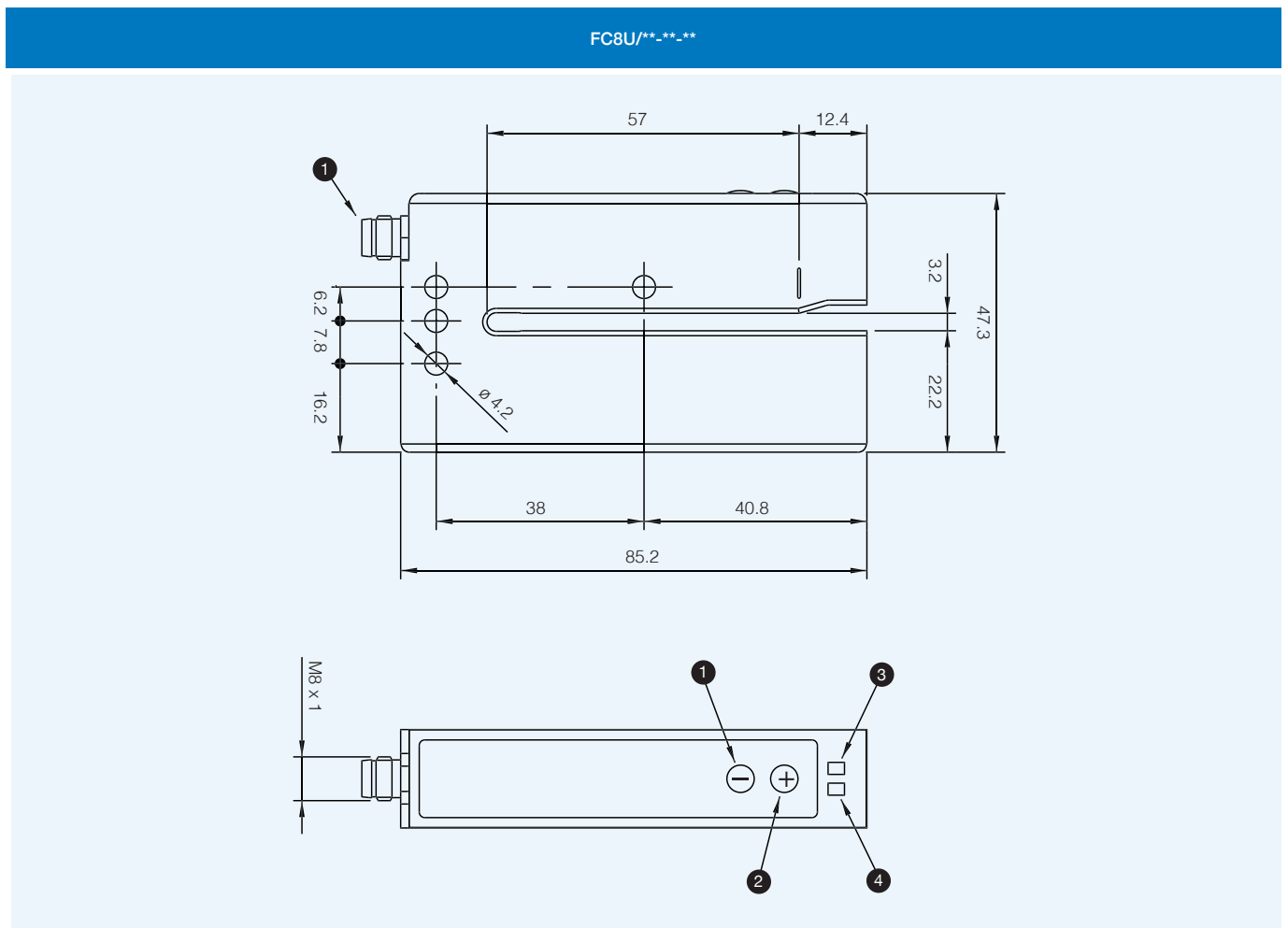

- 1 button -
- 2 button +
- 3 yellow LED, "ON" when the outputs are set to 1 (run)
- 4 red LED: keyboard lock and regulation