

Linear-Transducer LP38 - DN

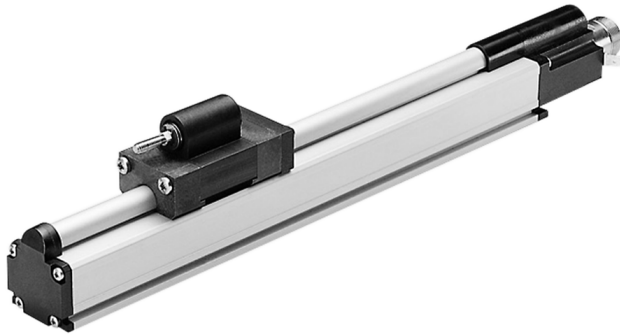

Ref.: K-LP38-DN-1

14.11.2013

0102010120

Advantages

- Customer-specific solutions
- Flexible programming
- Further interfaces available
- Measures linear movements
- Profile housing
- Simple integration
- Wear-free detection

General Data

Supply	
- Supply voltage	24 VDC, -20...+10 %
Current consumption no load	<= 250 mA
Measuring principle	magnetostrictive
Measuring length, standard	150...3000 mm, in steps
Resolution	0.01 mm
Linearity deviation	< 0.05 %
Reproducibility	0.01 mm
Hysteresis	0.1 mm
Temperature coefficient	< 8 $\mu\text{m}/^\circ\text{C}$ <= 500 mm < 15 ppm/ $^\circ\text{C}$ > 500 mm
Straight line velocity	no restrictions
Mounting position	no restrictions
Material - Measuring body	Aluminium extruded profile
Magnet	T4-U3820 other on request
CAN DeviceNet - Interface	
- CAN DeviceNet	EN 50325-2
- Bus connection	ISO 11898-1, ISO 11898-2
- CAN Specification 2.0 A	11-Bit Identifier

Subject to change.

TR-Electronic GmbH
Eglisshalde 6
78647 Trossingen
Tel. +49 (0) 7425 228-0
info@tr-electronic.de
www.tr-electronic.de

Linear-Transducer LP38 - DN

Ref.: K-LP38-DN-1

14.11.2013

0102010120

General Data continuation

Transmission rate	
- Specific value	125, 250, 500 kbit/s
- Adjustability	by means of DIP-switches
Parameter/Function, changeable	Resolution
	Preset parameter
	Counting direction
Type of parametrization	programmable
Prgramming - Tool	Fieldbus-Device
Cycle time, internal	see dimensional drawing
Optional Magnets	
- Number of magnets	16
- Magnet - Minimum distance	50 mm

Environmental conditions

Vibration	
- Specific value	$\leq 100 \text{ m/s}^2$
- Sine	50...2000 Hz
Shock	
- Specific value	$\leq 1000 \text{ m/s}^2$
- Half sine	11 ms
Immunity to disturbance	DIN EN 61000-6-2
Transient emissions	DIN EN 61000-6-3
Working temperature	
- Standard	0...+70 °C
- Optional	-20...+70 °C;
Storage temperature, dry	-30...+85 °C
Relative humidity	98 %, non condensing
Protection class	
- Standard	IP43
Stray magnetic field	< 3 mT
Measuring reference	Measuring plane

Subject to change.

Linear-Transducer LP38 - DN

Ref.: K-LP38-DN-1
 14.11.2013
 0102010120

Dimensional drawing

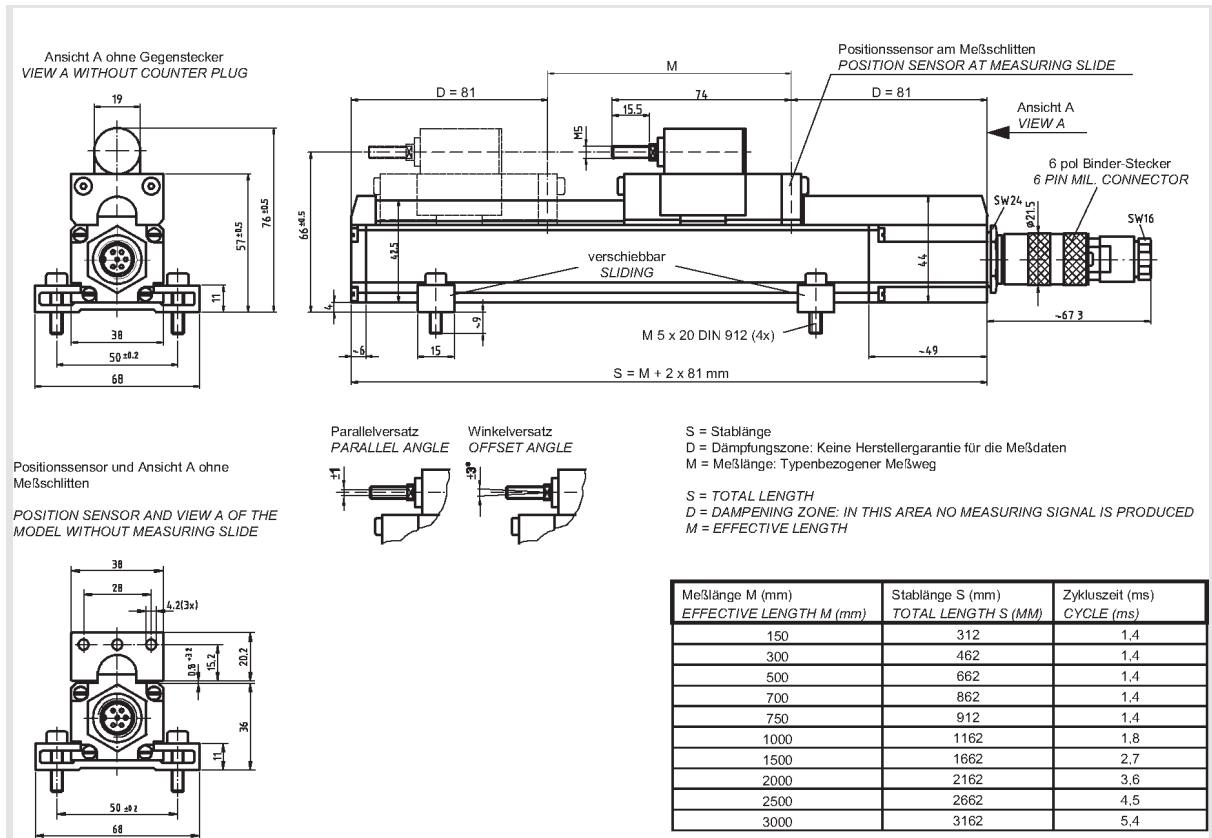

Subject to change.

TR-Electronic GmbH
 Eglshalde 6
 78647 Trossingen
 Tel. +49 (0) 7425 228-0
 info@tr-electronic.de
www.tr-electronic.de