

Linear-Transducer LMP30 - EIP

Ref.: K-LMP30-EIP-1

14.11.2013

0102010110

Advantages

- _ Customer-specific solutions
- _ Flexible programming
- _ Further interfaces available
- _ Measures linear movements
- _ Position value - Adjustment
- _ Profile housing
- _ Simple integration
- _ Wear-free detection

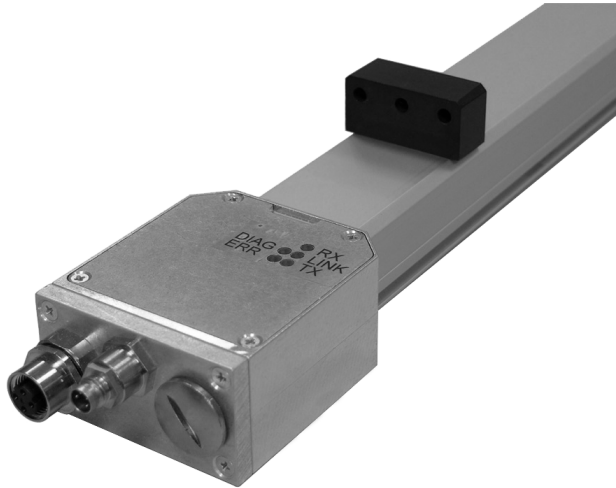

General Data

Supply	
- Supply voltage	24 VDC, -20...+10 %
Current consumption no load	<= 250 mA
Measuring principle	magnetostrictive
Measuring length, standard	50...2000 mm, in steps
Resolution	0.001 mm
Linearity deviation	± 0.10 mm <= 1500 mm ± 0.15 mm > 1500 mm
Reproducibility	0.005 mm
Hysteresis	0.02 mm <= 1500 mm 0.1 mm > 1500 mm
Temperature coefficient	< 8 µm/°C <= 500 mm < 15 ppm/°C > 500 mm
Straight line velocity	no restrictions
Mounting position	no restrictions
Material - Measuring body	Aluminium extruded profile
Magnet	T1-S3818 other on request
EtherNet/IP - Interface	
- EtherNet/IP	IEC 61784-1 CP 2/2, IEC 61158
- Physical Layer	Fast Ethernet, ISO/IEC 8802-3

Subject to change.

TR-Electronic GmbH
Eglisshalde 6
78647 Trossingen
Tel. +49 (0) 7425 228-0
info@tr-electronic.de
www.tr-electronic.de

Linear-Transducer LMP30 - EIP

Ref.: K-LMP30-EIP-1

14.11.2013

0102010110

General Data continuation

- Device profile	Encoder Device Profile 0x22
Transmission rate	
- Specific value	100 MBit/s
Parameter/Function, changeable	Resolution
	Preset parameter
	Position averaging
	Counting direction
Type of parametrization	programmable
Prgramming - Tool	Fieldbus-Device
	TR-Soft: TRWinProg
Cycle time internal, <= 0.50 m	0.50 ms
Cycle time internal, <= 1.00 m	1.00 ms
Cycle time internal, <= 2.00 m	1.50 ms
Optional Magnets	
- Number of magnets	3
- Magnet - Minimum distance	80 mm

Environmental conditions

Vibration	
- Specific value	<= 100 m/s ²
- Sine	50...2000 Hz
Shock	
- Specific value	<= 1000 m/s ²
- Half sine	11 ms
Immunity to disturbance	DIN EN 61000-6-2
Transient emissions	DIN EN 61000-6-3
Working temperature	
- Standard	0...+70 °C
- Optional	-20...+70 °C;
Storage temperature, dry	-30...+85 °C
Relative humidity	98 %, non condensing
Protection class	
- Standard	IP65
Stray magnetic field	< 3 mT
Measuring reference	Measuring plane

Subject to change.

Linear-Transducer LMP30 - EIP

Ref.: K-LMP30-EIP-1

14.11.2013

0102010110

Dimensional drawing

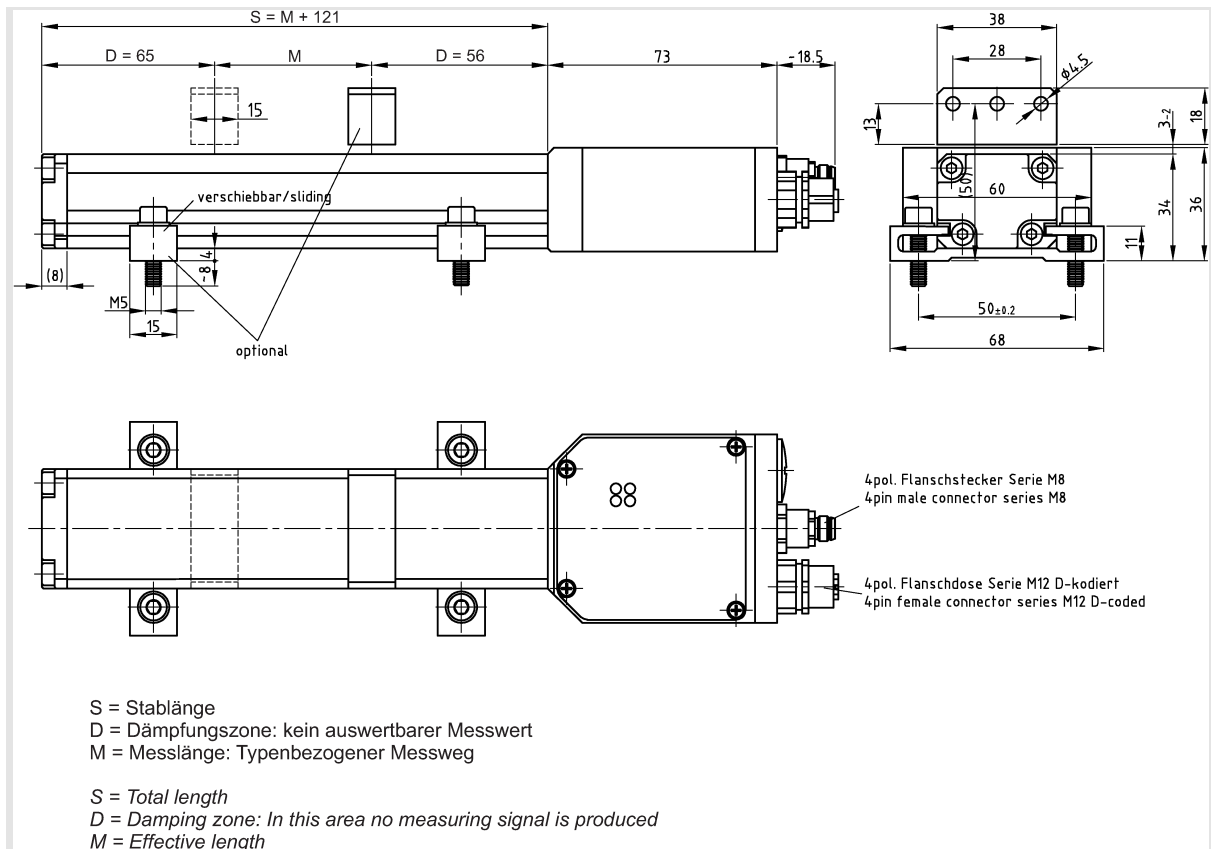

Subject to change.