

Absolute-Encoder CEV58 - AS

Ref.: K-CEV58-AS-1

18.11.2013

010102005802010201

Advantages

- _ Customer-specific solutions
- _ Flexible programming
- _ Further interfaces available
- _ Modular mechanical design
- _ Modular product line
- _ Short lead times

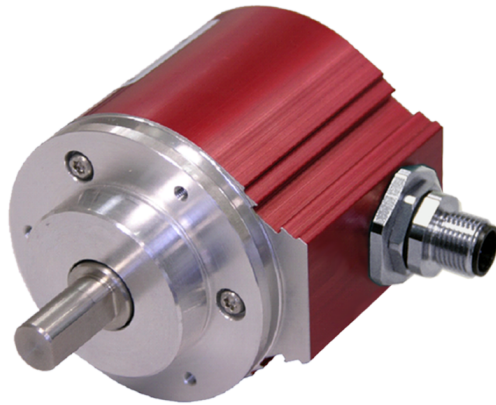

General Data

Supply	
- Supply voltage	29.5...31.6 VDC
Current consumption no load	<= 130 mA
Device design	
- Type	Single-/Multi-Turn
Total resolution	<= 28 Bit
Number of steps per revolution	<= 8192
Number of revolutions	<= 32768
Output capacity	<= 16 Bit
Actor-Sensor Interface	
- Actuator-Sensor-Interface	EN 50 295, IEC62026-2
- Data transmission	2-wire, unshielded
- Number of slaves	31 Slaves = 7 Encoder
- Bus access method	Master-Slave
Transmission rate	
- Specific value	53.3 kbit/s Netto
- Specific value	167 kbit/s Brutto
Cycle time	<= 5000 μ s (31 Slaves)
Parameter/Function, changeable	Resolution - Quartering
	Output code
	Zero adjustment
	Position value - storing

Subject to change.

TR-Electronic GmbH
 Eglisshalde 6
 78647 Trossingen
 Tel. +49 (0) 7425 228-0
 info@tr-electronic.de
www.tr-electronic.de

Absolute-Encoder CEV58 - AS

Ref.: K-CEV58-AS-1

18.11.2013

010102005802010201

General Data continuation

	Counting direction
Type of parametrization	programmable
Prgramming - Tool	Fieldbus-Device
Maximum Speed, mechanically	≤ 12000 1/min
Shaft load, axial/radial	≤ 10 N, ≤ 20 N
Bearing life time	$\geq 3.9E+10$ revolutions
Bearing life time - Parameter - Speed	6000 1/min
- Operating temperature	60 °C
- Shaft load, axial/radial	≤ 5 N, ≤ 10 N
Point of origin, shaft load	at the shaft end
Angular acceleration	$\leq 10E+4$ rad/s ²
Moment of inertia, typically	2.5E-6 kg m ²
Start-up torque, 20 °C	2 Ncm
Mass, typically	0.3...0.5 kg

Environmental conditions

Vibration	
- Specific value	≤ 100 m/s ²
- Sine	50...2000 Hz
Shock	
- Specific value	≤ 1000 m/s ²
- Half sine	11 ms
Immunity to disturbance	DIN EN 61000-6-2
Transient emissions	DIN EN 61000-6-3
Working temperature	
- Standard	0...+60 °C
- Optional	-20...+70 °C;
Storage temperature, dry	-30...+80 °C
Relative humidity	98 %, non condensing
Protection class	
- Standard	IP65

Subject to change.

Absolute-Encoder CEV58 - AS

Ref.: K-CEV58-AS-1
 18.11.2013
 010102005802010201

Dimensional drawing

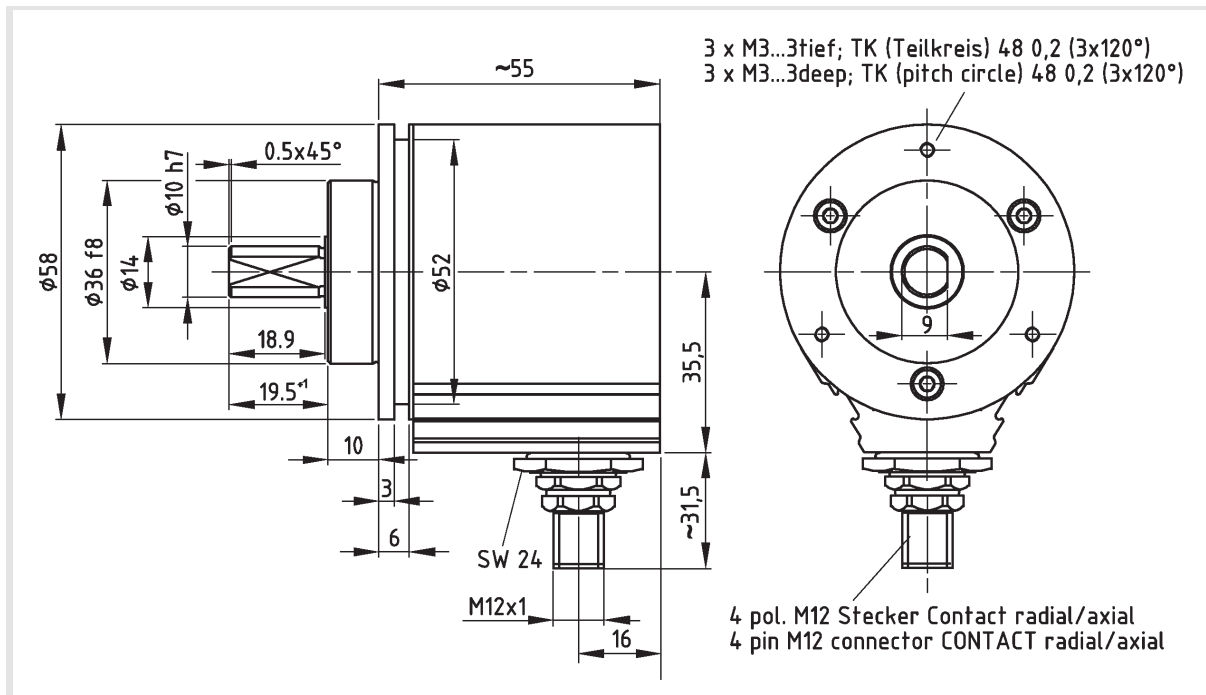

Subject to change.