

S5-5-D50-92

Fixed Distance Background Suppression

INSTRUCTION MANUAL

CONTROLS

OUTPUT LED (YELLOW)

The yellow LED indicates the output status.

CONNECTIONS

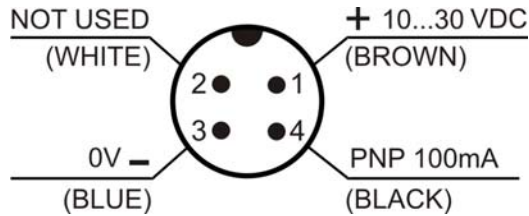

INSTALLATION

The operating distance is measured starting from the frontal side of the sensor's optical window referring to both the plastic lens spacer placed on the top and bottom of sensor optical window.

During the sensor installation, refer to the figure below. The optical window must be oriented in the same direction as showed in the figure. When the target moves in vertical axes the lenses must be oriented with TX and RX lenses on the horizontal axes.

The sensor has a fixed operating distance and the output logic in in light mode.

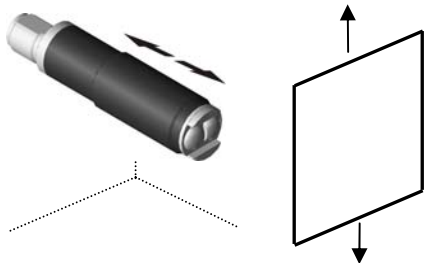

DIMENSIONS

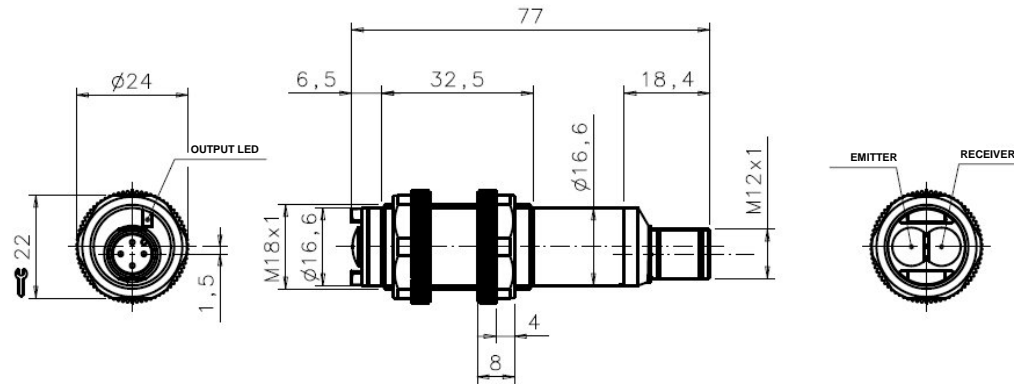

TECHNICAL DATA

Power supply:	10 ... 30 VDC
Ripple:	2 Vpp max
Current consumption (output current excluded):	< 30 mA
Outputs:	PNP N.O. (30 VDC max) (short-circuit protection at 200 mA)
Output current:	150 mA max
Output saturation voltage:	2.5 V max
Response time:	500 us
Switching frequency:	1 KHz
Indicators:	OUTPUT LED (YELLOW)
Setting:	-
Operating temperature:	-20 ... 60 °C
Storage temperature:	-20 ... 70 °C
Insulating strength:	500 VAC 1 min between electrical parts and enclosure
Insulating resistance:	>20 MΩ 500 VDC between electrical parts and enclosure
Operating distance (typical values):	0 ... 50 mm fixed (on 90% White)
Ripetibility:	5 %
Difference (90% White / 4% Black):	< 5 %
Hysteresis (90% White):	< 1 %
Emission type:	RED (660 nm)
Focusing distance:	50 mm
Spot dimension:	1.5 mm at focusing distance
Minimum detectable object:	1 mm
Ambient light rejection:	according to EN 60947-5-2
Vibrations:	0.5 mm amplitude, 10 ... 55 Hz frequency, for every axis (EN60068-2-6)
Shock resistance:	11 ms (30 G) 6 shock for every axis (EN60068-2-27)
Housing material:	ABS
Connector material:	Polycarbonate
Lens material:	Polycarbonate
Mechanical protection:	IP67
Connections:	M12 - 4 pole connector
Weight:	25 g. max.

SETTING

Please take in consideration this output operating logic during the installation. When the target is placed in front of the sensor at a distance which is equal or less then the operating distance the yellow output LED will be turned ON and the sensor output will be switched ON. When the object is placed in front of the sensor at a distance which is more than the operating distance the yellow output LED will be turned OFF and the sensor output will be turned OFF.

OPTICS DIAGRAMS

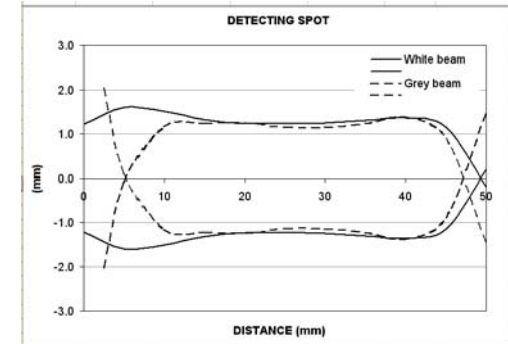
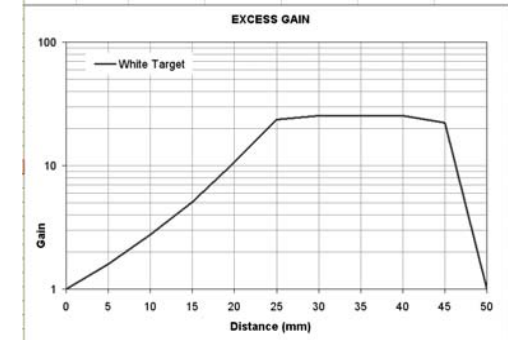

The sensors are NOT safety devices, and so MUST NOT be used in the safety control of the machines where installed.

DECLARATION OF CONFORMITY

We Datalogic Automation declare under our sole responsibility that these products are conform to the 2004/108/CE and successive amendments.



WARRANTY

Datalogic Automation warrants its products to be free from defects. Datalogic Automation will repair or replace, free of charge, any product found to be defective during the warranty period of 36 months from the manufacturing date. This warranty does not cover damage or liability deriving from the improper application of Datalogic Automation products.

DATALOGIC AUTOMATION srl

Via Lavino 265 - 40050 Monte S. Pietro - Bologna - Italy
Tel: +39 051 6765611 - Fax: +39 051 6759324 www.datalogic.com

DATALOGIC AUTOMATION cares for the environment: 100% recycled paper. DATALOGIC AUTOMATION reserves the right to make modifications and improvements without prior notification.

© 2010 - 2013 Datalogic Automation - ALL RIGHTS RESERVED - Protected to the fullest extent under U.S. and international laws. • Copying, or altering of this document is prohibited without express written consent from Datalogic Automation. Datalogic and the Datalogic logo are registered trademarks of Datalogic S.p.A. in many countries, including the U.S.A. and the E.U.