

Photoelectric sensors and proximity sensors

System description

Retroreflective photoelectric sensors

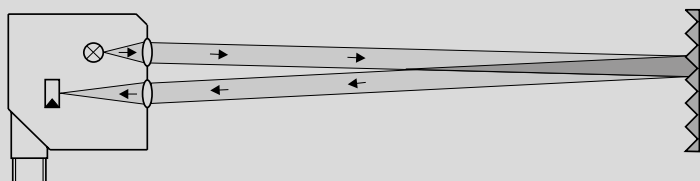

The transmitter and receiver are accommodated in a single housing in retroreflective photoelectric sensors. The light emitted by the transmitter hits a reflector and is reflected. The receiver evaluates the reflected light. The advantage lies in the small size of the reflector. It is also easy to install because it is a passive element and thus requires no connections.

Like through-beam photoelectric sensors, retroreflective photoelectric sensors are often selected according to the desired range. Because the light has to travel the path from the sensor to the reflector twice one also talks of the two-way photoelectric sensor. The light from the transmitter is, explained simply, emitted in a cone shape. This means that the cross-section of the light cone increases with rising range. This is also why a larger reflector is needed at longer ranges than at shorter distances. The range is therefore quoted in the data sheet in relation to the type of reflector.

Laser sensors provide an almost parallel light beam. Whereby the light beam is extremely fine and parallel over the entire operating range. This advantage is, above all, used when the smallest of objects have to be detected along the entire operating range. Regardless of the physical principle, all retroreflective photoelectric sensors from SensoPart have a so-called polarisation filter. Polarisation filters are optical filters that let the light beams through only in one direction. Use of a polarisation filter in combination with pyramidal reflectors can also allow the reliable detection of reflective objects by retroreflective photoelectric sensors.

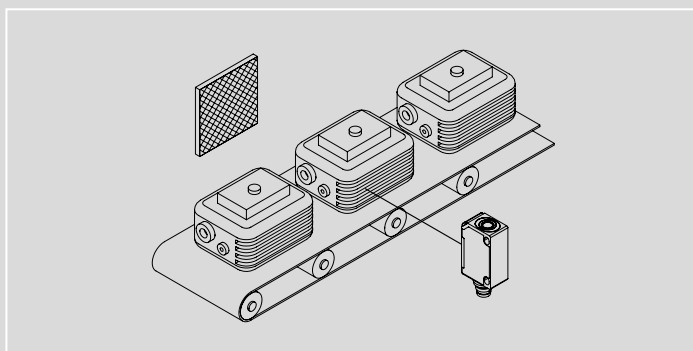

Checking completeness

The presence of the inserted components must be checked before further production steps.

The autocollimation principle



With retroreflective photoelectric sensors one speaks of the autocollimation principle when the light reflected from the reflector travels parallel to itself (i.e. within itself). The light emitted by the sensor hits a reflector and is reflected. The reflected light is then deflected to a receiver by a semi-transparent mirror and evaluated.

The autocollimation principle

Unlike the double-lens system, a retroreflective photoelectric sensor using the autocollimation principle has a very homogeneous and narrow optical path. Its switching point is largely independent of the entry direction of the target object.

A major advantage of sensors with the autocollimation principle is detection from a range of 0 mm. There is thus, unlike the double-lens system, no blind zone.

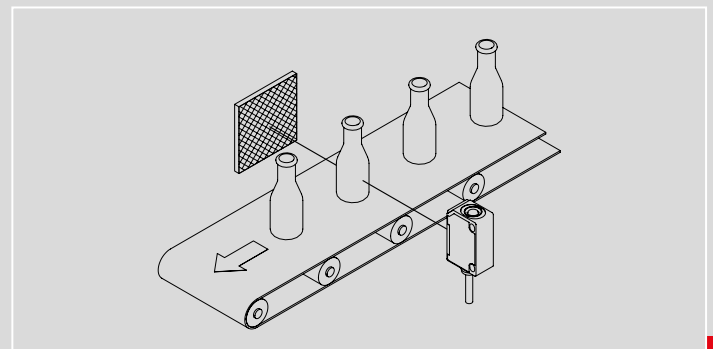

Monitoring bottles

The retroreflective photoelectric sensor specially developed for this purpose achieves reliable detection of transparent objects.

Through-beam photoelectric sensors

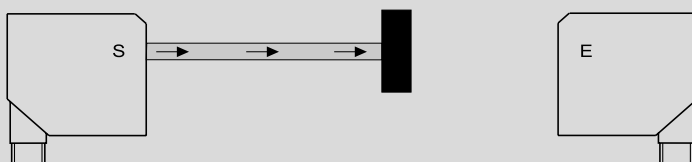
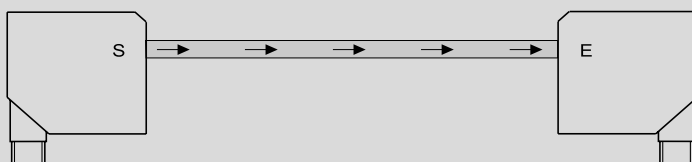

A through-beam photoelectric sensor has a separate transmitter and receiver. This means that light only travels the path between the transmitter and the receiver once. For this reason one speaks of through-beam photoelectric sensors.

The range is of decisive importance when using through-beam photoelectric sensors. Photoelectric sensors are principally selected according to their range. In the case of very critical operating conditions, such as high dust levels or intense steam generation, care must be taken to ensure that the photoelectric sensor is not operated at its limit range. Any clouds of steam

would reduce the available range. The range quoted in the data sheet should not be exceeded – in order to ensure functionality in poor operating conditions.

When using deflector mirrors, the total path to be monitored should be less than the range quoted in the data sheet.

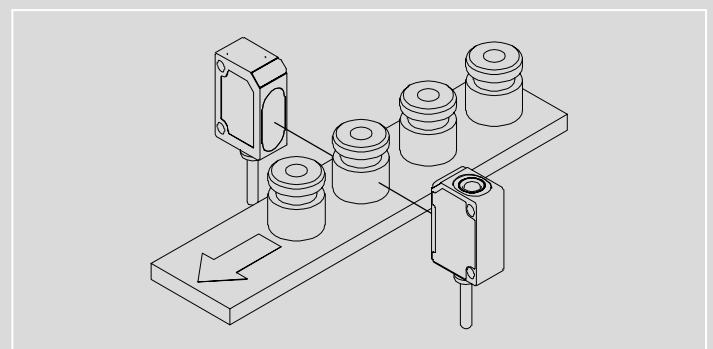

Detecting workpieces in harsh environments

Through-beam photoelectric sensors can also provide dependable detection even under poor conditions – thanks to their high level of reliability.

Photoelectric sensors and proximity sensors

System description

Proximity sensors with background suppression

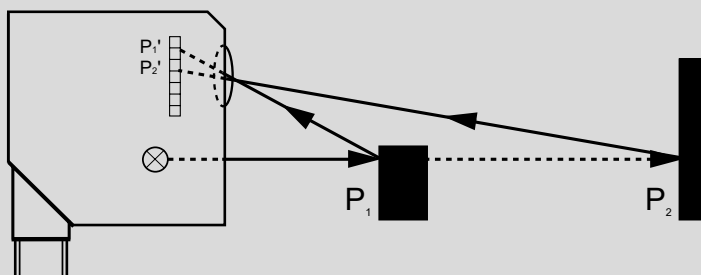

Advantages

- Independent of object colour and surface
- Reflections in the background are reliably suppressed
- Robust in sunshine
- Scanning distance adjustable according to applications

Differing object colours and surfaces can seriously affect the detection behaviour of a diffuse scanner. As a result of the purely energetic evaluation it is not possible, for example, to detect a black object against a white background. The white background reflects more light than the object itself.

The background suppression process was developed in order to be able to reliably master such tasks. Whereby both the light returning from the background as well as that reflected by the object are evaluated. The light hits two different positions (P_1' & P_2') on the receiver element.

So it is not the returning energy, but the geometrical position of the target object that is evaluated (triangulation). With this process one can, for example, reliably detect a dark object on a light conveyor belt.

There are various ways to physically achieve background suppression. Generally one differentiates between a fixed and an adjustable background suppression.

In the case of fixed background suppression, the transmitter and receiver elements are fixed-mounted. The operating range is defined by the overlapping of the transmitter and receiver angles. Objects outside this operating range cannot be detected.

In the case of adjustable background suppression, the parameters for object detection can be set mechanically via a rotary switch or electronically via teach-in. This provides much more flexible use.

Laser devices are particularly suitable for detecting the smallest of objects. A red-light sensor should be employed for larger objects.

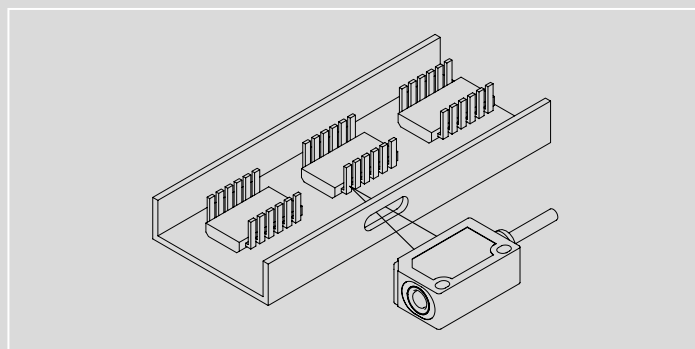

Monitoring pins

The fine light beam of the laser sensor permits the precise detection of even such small objects without any impairment by the background.

Proximity sensors 

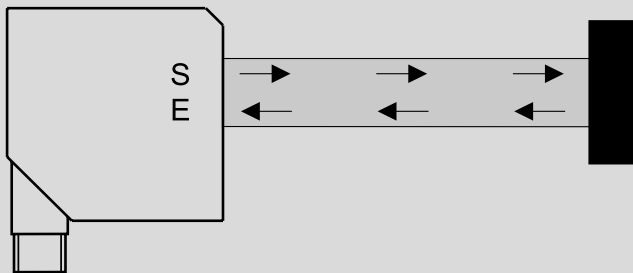

The transmitter and receiver of a proximity sensor are accommodated in a single housing. The light emitted by the transmitter hits the target object, which reflects the light. This returning light is evaluated by the receiver. The advantage of this method is that no reflector is required.

Because the scanner evaluates the reflected light and its energy, the range of conventional scanners (also called energetic or diffuse scanners) is largely dependent on the object's colour and its surface properties. Because black objects strongly absorb light, diffuse scanners can only achieve a very short range here. The surface structure is responsible for the type of reflection. Very rough, heterogeneous surfaces reflect diffusely, i.e. in all directions. Only a small percentage of the reflected light returns to the receiver. The scanning distance in this case is also low.

Proximity sensors based on energetic evaluation are therefore particularly suitable for the detection of larger objects or of objects whose material colour and surface properties remain constant.

One must also ensure that the quantity of light reflected back from the background is not greater than that reflected by the object itself. This effect occurs, for example, when a black object is in front of a white background. In this case detection with an energetic scanner is impossible. The use of a scanner with background suppression is recommended here.

The reliable detection of objects is possible if the background of the object is free, for example when an energetic scanner is mounted transversely over a conveyor belt. The setting of the sensor on the varying object surfaces and backgrounds takes place by means of a mechanical rotary switch on the sensor or via teach-in. The sensor can be set to a maximum scanning distance for a detection task without a background. A precise setting is necessary for applications with a background.

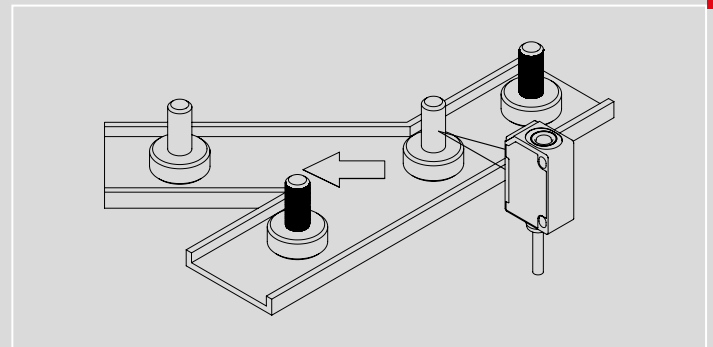

Rejection of uncoated parts

Brightness differences can be reliably detected by a diffuse scanner.