

Rotary Encoders

Linear Encoders

Motion

Positioning-
System

PROFI[®]
BUS

BE-90 PB



- Software/Support CD: 490-01001
- Soft-No.: 490-00406

User Manual

Barcode positioning system BE-90 PB with PROFIBUS-DP interface

- [Safety instructions](#)
- [Technical data](#)
- [Installation](#)
- [Commissioning](#)
- [Configuration / Parameterization](#)
- [Maintenance](#)



TR-Electronic GmbH

D-78647 Trossingen
Eglishalde 6
Tel.: (0049) 07425/228-0
Fax: (0049) 07425/228-33
E-mail: info@tr-electronic.de
<http://www.tr-electronic.de>

Copyright protection

This Manual, including the illustrations contained therein, is subject to copyright protection. Use of this Manual by third parties in contravention of copyright regulations is forbidden. Reproduction, translation as well as electronic and photographic archiving and modification require the written content of the manufacturer. Offenders will be liable for damages.

Subject to amendments

Any technical changes that serve the purpose of technical progress, reserved.

Document information

Release date/Rev. date:	02/16/2011
Document rev. no.:	TR - E - BA - GB - 0025 - 07
File name:	TR-E-BA-GB-0025-07.DOC
Author:	MÜJ

Font styles

Italic or **bold** font styles are used for the title of a document or are used for highlighting.

`Courier` font displays text, which is visible on the display or screen and software menu selections.

" < > " indicates keys on your computer keyboard (such as <RETURN>).

Trademarks

PROFIBUS-DP and the PROFIBUS logo are registered trademarks of PROFIBUS Nutzerorganisation e.V. (PNO) [PROFIBUS User Organization]

SIMATIC is a registered trademark of SIEMENS corporation

Table of Contents

Table of Contents	3
Revision index	5
1 General information	6
1.1 Explanation of symbols.....	6
2 Safety notices	7
2.1 Safety standards.....	7
2.2 Intended use	7
2.3 Working safely	8
3 Description.....	10
3.1 BE-90 PB device construction	10
3.2 Application	10
3.3 Function	11
3.4 Advantages.....	11
3.5 Modular hoods with integrated connectors BE-90 CU PB3/BE-90 CU PB5	11
4 Technical data.....	12
4.1 General specifications BE-90 PB	12
4.2 Barcode band	13
4.3 LED indicators	14
4.4 Device construction and components.....	14
4.5 Dimensioned and connecting drawings.....	15
5 Barcode tape.....	17
5.1 General information	17
5.2 Specifications of the barcode tape	18
5.3 Mounting the barcode tape.....	19
6 Order designation.....	22
6.1 Read head, RH (stand-alone unit).....	22
6.2 Connection-Unit, CU (modular hood).....	23
6.3 Profibus Connector, CO	23
6.4 Software, SW.....	24
6.5 Fastening accessories, FA	25
6.6 Special barcode band, BC.....	26
6.6.1 Special barcode band (replacement).....	26
7 Installation.....	27
7.1 Storage, Transportation	27
7.2 Mounting	28
7.2.1 Device arrangement	29
7.3 Address setting	32

7.4 Connection.....	32
7.4.1 Connecting the BE-90 PB.....	33
7.4.2 Connection of switching inputs and outputs	35
7.5 Disassembling, Packing, Disposing.....	35
8 Profibus	36
8.1 General information	36
8.1.1 GSD File	36
8.2 Structure of the project modules.....	36
8.2.1 Overview of the project modules	37
8.2.2 Module 1: Position value.....	39
8.2.3 Module 2: Resolution	40
8.2.4 Module 3: Static preset	40
8.2.5 Module 4: Dynamic preset.....	41
8.2.6 Module 5: Offset value.....	42
8.2.7 Module 6: Scaling	42
8.2.8 Module 7: Switching input.....	43
8.2.9 Module 8: Switching output.....	44
8.2.10 Module 9: Controller	46
8.2.11 Module 10: Measurement value acquisition	48
8.2.12 Module 11: Measurement value processing.....	49
8.2.13 Module 12: Status.....	50
8.2.14 Module 13: Min – Max position	51
8.2.15 Module 14: Static limit value 1	52
8.2.16 Module 15: Static limit value 2	53
8.2.17 Module 16: Dynamic limit value 1	54
8.2.18 Module 17: Dynamic limit value 2	55
8.2.19 Module 18: Measuring error tolerance.....	56
8.2.20 Module 19: Service	57
8.2.21 Module 20: Velocity	58
8.2.22 Module 21: Velocity parameters	59
8.2.23 Module 22: Velocity measurement control	60
8.2.24 Module 23: Velocity	61
8.2.25 Module 24: Min/Max velocity	62
8.2.26 Module 25: Static velocity limit values	63
8.2.27 Module 26: Dynamic velocity limit value	65
9 Commissioning.....	66
9.1 Measures to be performed prior to the initial commissioning.....	66
9.2 Function Test.....	66
10 Maintenance.....	67
10.1 General maintenance information	67
10.2 Repairs, Servicing.....	67

Revision index

Revision	Date	Index
First release	07/08/02	00
Profibus connector for "POWER IN"	10/17/02	01
Correction of the operating range	01/28/03	02
- Additional information about the laser radiation in chap. "Working safely" - Additional information's about the connection of the protective conductor PE	11/13/03	03
- Note: No use into environments with direct sunlight exposure	11/14/06	04
- New chapter added "5 Barcode tape"	05/07/09	05
- New functionalities: Software state V2.20 from October 2004 Expansion of the GSD file with the modules M18 to M26	03/29/10	06
- Operating range modified - Mounting drawing for fastener added	02/16/11	07

1 General information

1.1 Explanation of symbols

The symbols used in this operating manual are explained below.



Attention!

Pay attention to passages marked with this symbol. Failure to heed this information can lead to injuries to personnel or damage to the equipment.



Attention Laser!

This symbol warns of possible danger through hazardous laser radiation.



Notice!

This symbol indicates text passages containing important information.

2 Safety notices

2.1 Safety standards

The barcode positioning system BE-90 PB and the modular hoods with integrated connectors BE-90 CU PB3/BE-90 CU PB5 have been developed and manufactured under observation of the applicable European standards and directives.

2.2 Intended use



Attention!

The protection of personnel and the device cannot be guaranteed if the device is operated in a manner not corresponding to its intended use.

Barcode positioning systems of the type BE-90 PB are optical measuring systems which use visible red laser light to determine the position of the BE-90 relative to a permanently mounted barcode band.

The modular hoods with integrated connectors BE-90 CU PB3/BE-90 CU PB5 are intended for the easy connection of barcode positioning systems of type BE-90 PB in a Profibus system and for the setting of the respective Profibus address (see chapter 7.3 "Address setting").

In particular, unauthorised uses include:

- rooms with explosive atmospheres
- operation for medical purposes
- into environments with direct sunlight exposure or with suitable protection device only

Areas of application

The barcode positioning system BE-90 PB has been developed in particular for the following areas of application:

- High-bay storage devices and lifting gear
- Crane systems
- Side-tracking skates
- Transfer machines
- Telpher lines

2.3 Working safely



Attention Laser Radiation!

The barcode positioning system BE-90 PB operates with a red light laser of class 2 acc. to EN 60825-1 (2001/11). It also complies with the U.S. 21 CFR 1040 regulations for a class II product. If you look into the beam path over a longer time period, the retina of your eye may be damaged!

Never look directly into the beam path!

Do not point the laser beam of the BE-90 PB at persons!

When mounting and aligning the BE-90 PB, take care to avoid reflections of the laser beam off reflective surfaces!

The use of operating and adjusting devices other than those specified in this technical description, carrying out of differing procedures, or improper use of the barcode positioning system may lead to dangerous exposure to radiation!

The use of optical instruments or devices in combination with the device increases the danger of eye damage!

Adhere to the applicable legal and local regulations regarding protection from laser beams acc. to EN 60825-1 in its latest version.

The BE-90 PB uses a laser diode with low power in the visible red light range with an emitted wavelength of about 650nm. The output power of the laser beam at the reading window is at most 1.8 mW acc. to EN 60825-1 (2001/11).

The reading window is the only opening through which the laser radiation can escape from the device. The housing of the BE-90 PB is sealed and has no parts that need to be adjusted or maintained by the user. The device must not be tampered with and must not be changed in any way!

i

Notice!

It is important that you attach the sticky labels supplied to the device (notice signs and laser emission symbol)! If the signs would be covered due to the installation situation of the BE-90 PB, attach them close to the BE-90 PB such that reading the notices cannot lead to looking into the laser beam!



Figure 2-1: Example for the attachment of the sticky label with warning notices



Attention!

Access to or changes on the device, except where expressly described in this operating manual, is not authorised.

Safety regulations

Observe the locally applicable legal regulations and the rules of the employer's liability insurance association.

Qualified personnel

Mounting, commissioning and maintenance of the device must only be carried out by qualified personnel.

Electrical work must be carried out by a certified electrician.

3 Description

Information on technical data and characteristics can be found in chapter 4.

3.1 BE-90 PB device construction

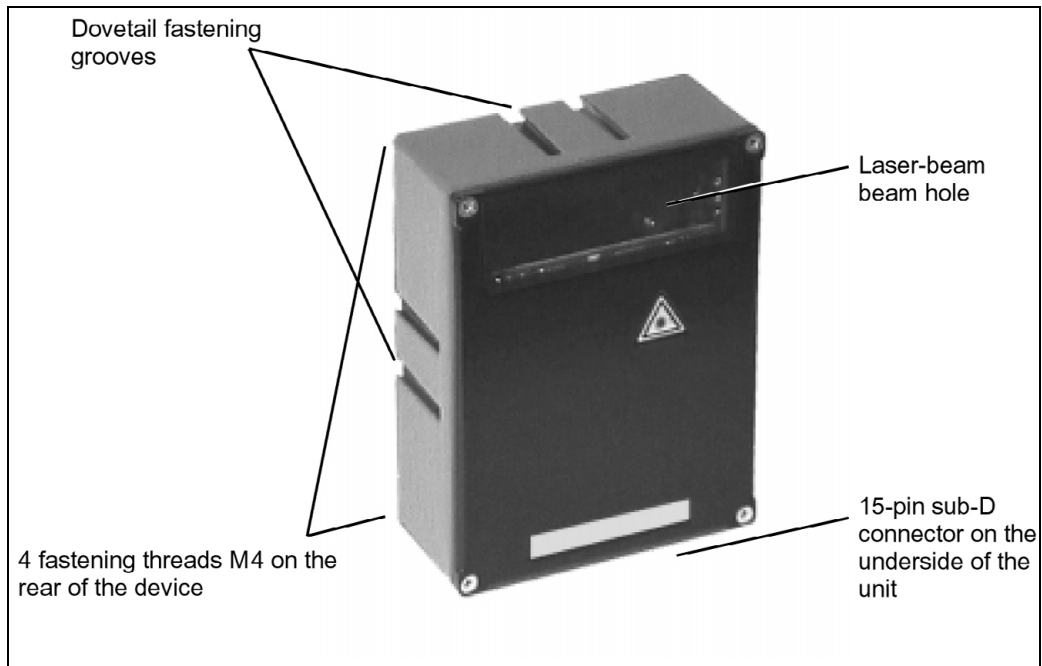

Figure 3-1: BE-90 PB device construction

3.2 Application

Anywhere systems are moved automatically, it is necessary to correctly determine their positions. This is achieved using various measurement techniques. In addition to mechanical measurement sensors, optical methods are particularly well suited for determining positions as they operate without mechanical wear and slippage.

Unlike other optical measurement methods, the barcode positioning system is not restricted to linear movements. It can also be used flexibly in curved systems. Anywhere the longwearing barcode band can be attached, it is possible to use the BE-90 to determine the position to within a millimetre.

Guide tolerances of the system play no roll as the permitted separation between band and BE-90 allows for large deviations in distance.

3.3 Function

The BE-90 uses visible red laser light to determine its position relative to the barcode band. This essentially takes place in three steps:

1. Reading a code on the barcode band
2. Determining the position of the read code in the scanning area of the laser beam
3. Calculating of the position to within a millimetre using the code information and the code position

The position value is then transferred to the controller via the Profibus DP.

3.4 Advantages

- Easy installation and commissioning
- Teach function for the "zero point", i.e. it is not necessary to exactly affix the barcode band.
- Data output via the integrated Profibus DP.
- The function of the BE-90 makes it possible to attach the barcode band only at those locations where it is necessary that the position be known exactly.
- Positioning of non-linear movements as well
- No referencing necessary following voltage drop
- Thanks to the large scanning depth, it is possible to compensate for mechanical tolerances.
- It is possible to exactly determine positions from distances of 10000 metres.

3.5 Modular hoods with integrated connectors BE-90 CU PB3/BE-90 CU PB5

The modular hoods with integrated connectors are necessary accessories for connecting a BE-90 PB in a Profibus system. They are used to feed through the Profibus connections, set the Profibus address and supply voltage to the BE-90 PB.

BE-90 CU PB3

The BE-90 CU PB3 offers the following interfaces:

- Profibus In (DP IN)
- Profibus Out (DP OUT)
- voltage supply (PWR IN)

BE-90 CU PB5

In addition, the BE-90 CU PB5 offers the following interfaces:

- switching inputs and outputs (SW IN/OUT)

Please refer to chapter 6 for further information regarding the modular hoods with integrated connectors.

4 Technical data

4.1 General specifications BE-90 PB

Optical Data

Light source	Laser diode 650 nm
Scanning rate	1000 scans/sec.

Measurement data

Reproducible accuracy	±1 (2) mm
Integration time	16 (8) ms
Measurement value output	500 values/sec.
Refresh time	2 ms
Scanning depth	90 ... 170 mm

Electrical data

Interface type	Profibus DP
Service Interface	RS232 with fixed data format, 9600 baud, 8 data bits, no parity, 1 stop bit
Ports	1 switching output, 1 switching input
LED green	device ready (Power On)
Operating voltage	10 ... 30 V
Power consumption	5 W

Mechanical data

Protection class	IP 65
Weight	400 g
Dimensions (H x B x T)	120 x 90 x 43 mm
Housing	diecast aluminium

Environmental data

Operation without optics heating	0°C ... +40°C
Operating with optics heating	-30°C ... +40°C
Storage	-20°C ... +60°C
Air humidity	max. 90% rel. humidity, non-condensing
Vibration	IEC 68.2.6 IEC 68.2.27 (shock) IEC 801
Electromagnetic compatibility	acc. to IEC 60947-5-2

Table 4-1: General Specifications

4.2 Barcode band

Max. length (measurement length)	10 000 m
Ambient temperature	-40°C ... +120°C
Mechanically characteristics	Resistantly against scratch and wipe, UV-light, humidity, chemicals and solvents (restricted).

Further details see page 17, and the following pages.

4.3 LED indicators

BE-90 PB

A **BE-90 PB** internal green LED indicates in the reading window whether or not the supply voltage is present.

BE-90 CU PB3 / BE-90 CU PB5

On top of the modular hood with integrated connectors a red/green status LED is located between the M12 connectors DP IN and DP Out. It indicates the state of the Profibus connection.

State	Meaning
off	voltage off
green flashing	initialisation of the device, establishment of the PROFIBUS communication
green, continuous light	data operation
red, flashing	error on PROFIBUS, error can be resolved by a reset
red, continuous light	error on PROFIBUS, error cannot be resolved by a reset
orange, continuous light	SERVICE operation active

Table 4-2: LED states BE-90 CU PB3 / BE-90 CU PB5

4.4 Device construction and components

A modular hood with integrated connectors of the type BE-90 CU PB3 or BE-90 CU PB5 is always part of a BE-90 PB. The purpose of both hoods is to connect the BE-90 PB to the Profibus. For this, they feature one Profibus IN and one Profibus OUT connection each, as well as an internal switch for address setting.

If only the connection to the Profibus is intended, type BE-90 CU PB3 is sufficient.

If, in addition, switching input and output are to be connected, an BE-90 CU PB5 is required. Although switching inputs and outputs are available on the voltage supply connector, the switching inputs of the BE-90 CU PB5 have the advantage that a standard sensor connector can be used.



Figure 4-1: BE-90 PB with BE-90 CU PB5

4.5 Dimensioned and connecting drawings

BE-90 PB

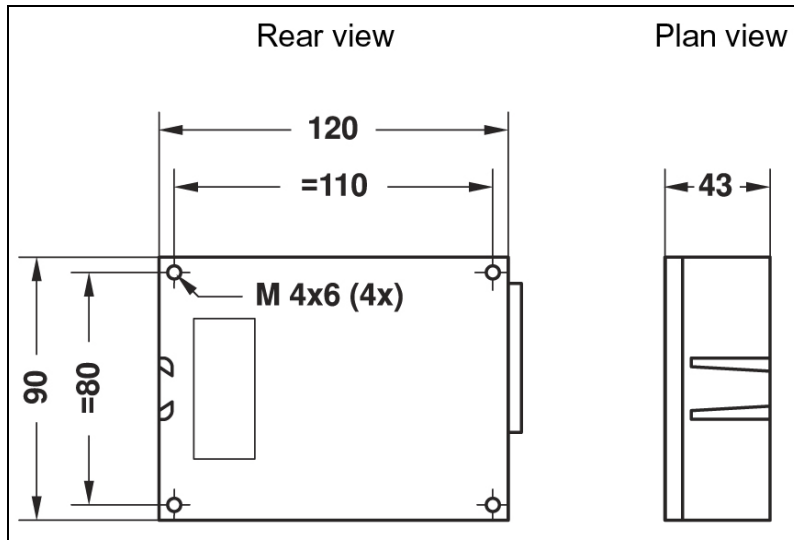

Figure 4-2: Dimensioned Drawing BE-90 PB

BE-90 CU PB3 / BE-90 CU PB5

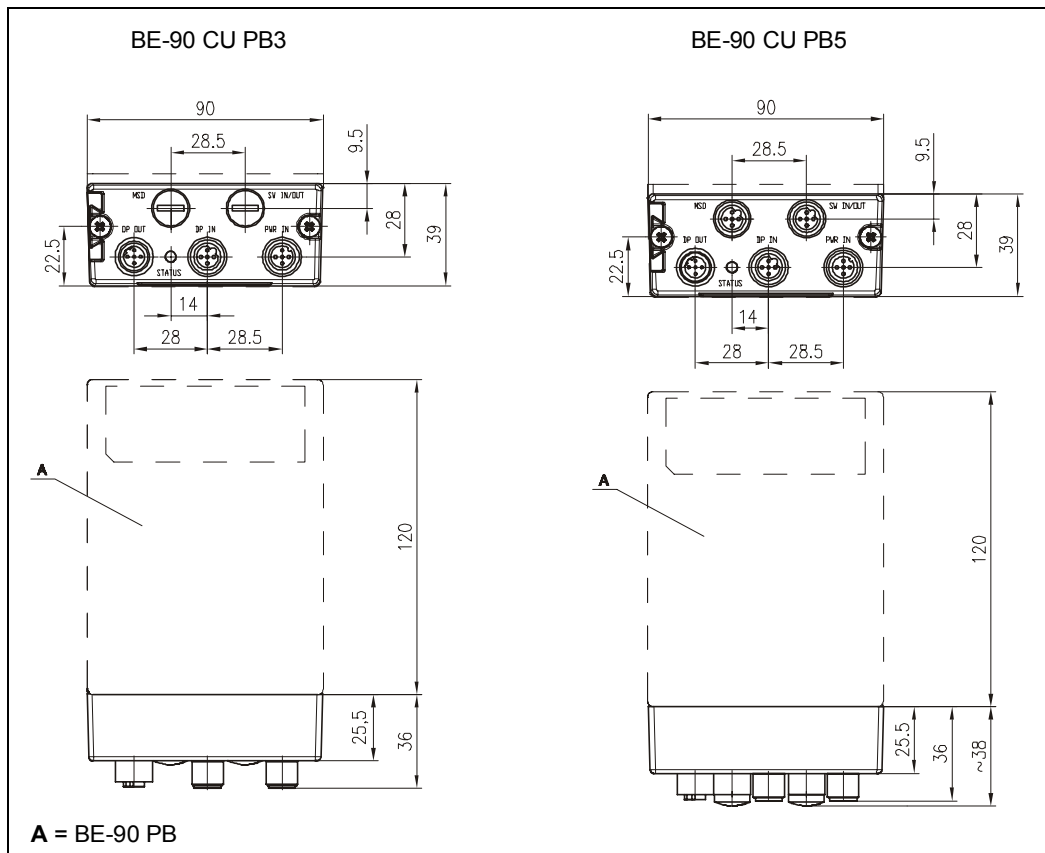

Figure 4-3: Dimensioned drawing BE-90 CU PB3 / BE-90 CU PB5

Scanning Curve BE-90 PB

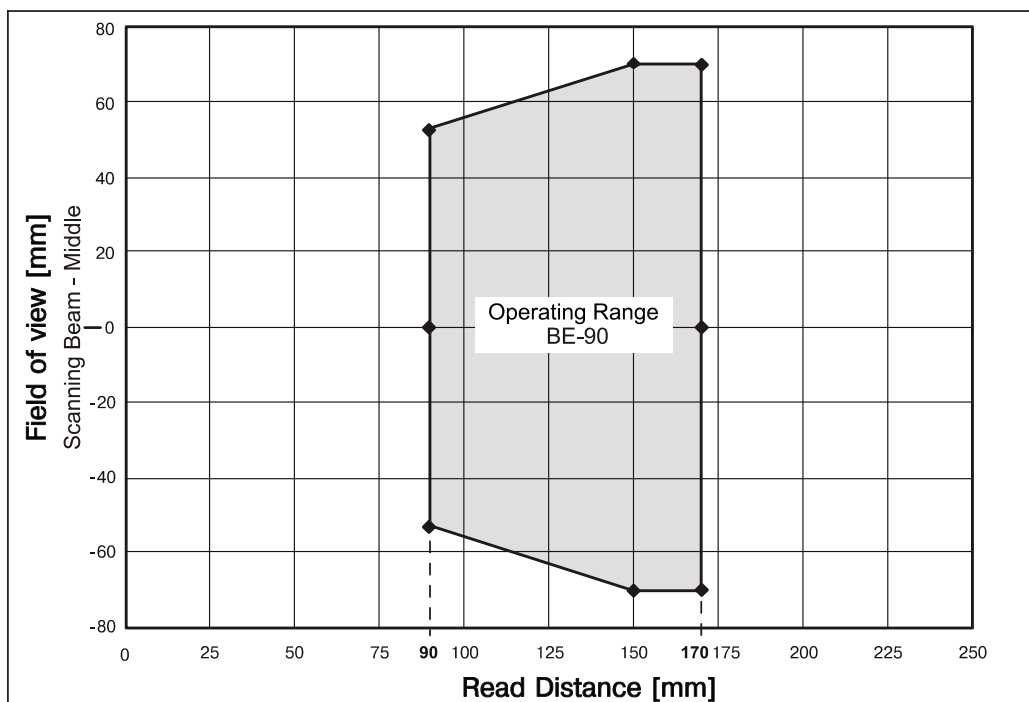

Figure 4-4: Scanning Curve BE-90 PB

5 Barcode tape

5.1 General information

The barcode tape is delivered on a roll. A roll contains up to 200m of barcode tape, with the wrapping direction from the outside to the inside (smallest number on the outside). If a barcode tape is ordered which is considerably longer than 200m, the total length is divided into rolls of 200m each.



Figure 5-1: Roll with barcode tape

Features:

- Robust and durable polyester adhesive tape
- High dimensional stability
- Max. length 10.000 m
- Self-adhesive, high adhesive strength

5.2 Specifications of the barcode tape

Dimensions	
Standard height	47 mm (other heights on request)
Length	0 ... 5 m, 0 ... 10 m, 0 ... 20 m, ..., 0 ... 150 m, 0 ... 200 m, special lengths and special codings for lengths from 150 m
Construction	
Manufacturing process	Filmsetting
Surface protection	Polyester, matt
Base material	Polyester film, affixed without silicone (0.08mm)
Adhesive	Acrylate adhesive
Adhesive thickness	0.1 mm
Adhesive strength (average values)	on aluminium: 25 N/25 mm on steel: 25 N/25 mm on polycarbonate: 22 N/25 mm on polypropylene: 20 N/25 mm
Environmental data	
Recom. processing temperature	0 °C ... +45 °C
Temperature resistance	-40 °C ... +120 °C
Dimensional stability	no shrinkage, tested according to DIN 30646
Curing	final curing after 72 h, the position can be detected immediately by the BE-90 after the barcode tape is affixed
Thermal expansion	due to the high elasticity of the barcode tape, thermal expansion of the base material on which the barcode tape is affixed is not known to have an effect
Tearing resistance	150N
Elongation at tear	min. 80 %, tested in accordance with DIN 50014, DIN 51220
Weathering resistance	UV-light, humidity, salt spray (150h/5%)
Chemical resistance (tested at 23 °C for 24 h)	transformer oil, diesel oil, white spirit, heptane, ethylene glycol (1:1)
Behaviour in fire	self-extinguishing after 15 s, does not drip
Mounting surface	grease-free, dry, clean, smooth

Table 5-1: Specifications of the barcode tape

5.3 Mounting the barcode tape

To prevent deposits of dirt from forming, it is recommended that the barcode tape be affixed vertically, possibly with a roof-like cover. If the application does not permit this, permanent cleaning of the barcode tape by on-board cleaning devices such as brushes or sponges is not permitted in any case. Permanent on-board cleaning devices polish the barcode tape and give it a glossy finish. The read quality deteriorates as a result.

i **Notice!**

When mounting the barcode tape, it must be ensured that neither strong sources of extraneous light nor reflections of the base on which the barcode tape is affixed occur in the area of the scanning beam.

The recommended interruption points on the barcode tape are at the provided cut marks.

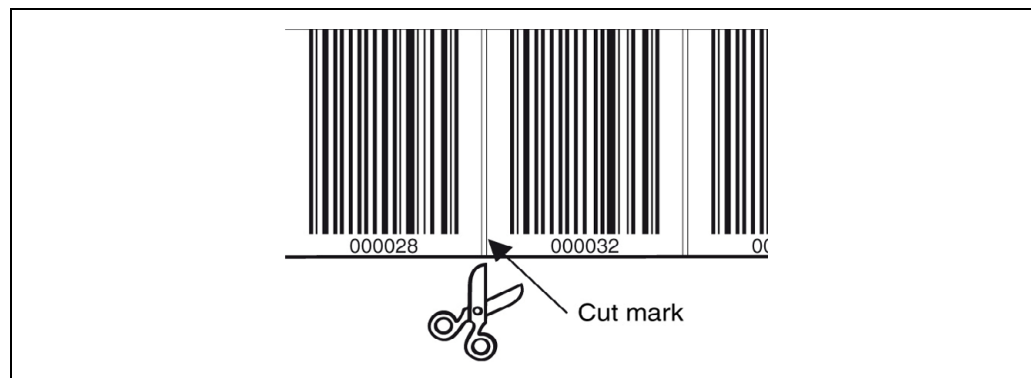

Figure 5-2: Cut mark on the barcode tape

i **Notice!**

Cutting the barcode tape and affixing the tape so that a gap forms which is so large that a label can no longer be reliably detected in the scanning beam results in double positions during the position calculation of the BE-90. The gap must not be greater than the distance from one cut mark to the next (max. one label).

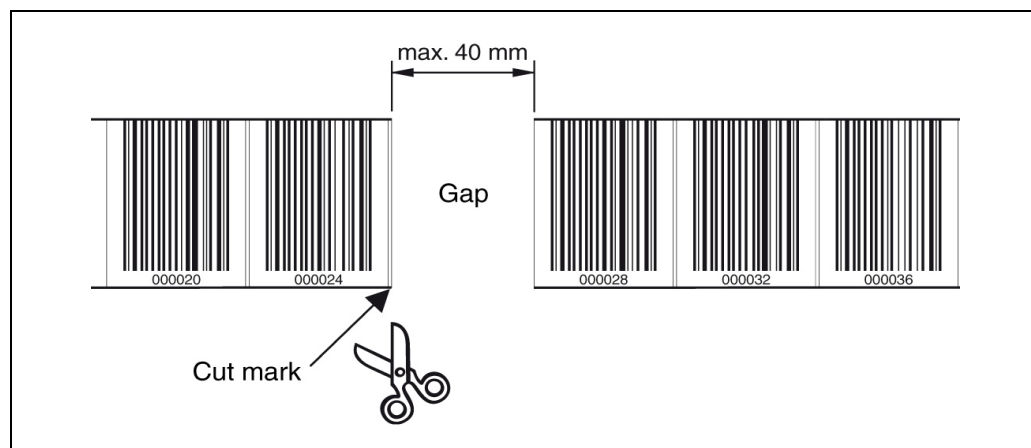

Figure 5-3: Gap in the cut barcode tape

Procedure:

- Examine the mounting surface. It must be flat, without warping, free of grease and dust, and dry.
- Define a reference edge (e.g. metal edge of the busbar)
- Remove the backing and affix the barcode tape along the reference edge tension free. Secure the barcode tape to the mounting surface by pressing down with the palm of your hand. When affixing, make certain that the barcode tape is free of folds and creases and that no air pockets form.
- Never pull the barcode tape. Because this is a plastic tape, forceful pulling may stretch it. This results in a distortion of the measurement units on the tape. While the BE-90 can still perform the position calculation, the accuracy in this case is no longer ensured. If the values are taught using a teach-in process, distortions are irrelevant.
- Expansion joints with widths up to several millimetres can simply be covered with the barcode tape. The tape must not be interrupted at this location.
- Protruding screw heads can simply be taped over. Cut out the bar code which covers the screw head at the cut marks.
- If the application dictates the necessity of a gap, the tape is to be affixed over this gap and the affected cut marks cut out. If the gap is small enough that the scanning beam can detect the label to the left or to the right of the gap, measurement values are delivered without interruption. If the scanning beam cannot completely scan any label, the BE-90 returns the value 0. As soon as the BE-90 can again scan a complete label, it calculates the next position value.
- The maximum gap between two barcode positions without affecting the measurement value is 40 mm.

**Attention!**

Barcode tapes with different value ranges may not directly follow one another. If the value ranges are different, the gap between the two barcode tapes must be greater than the detection range of the scanning beam or control barcodes must be used.

i **Notice!**

When working with the barcode tap in cold warehouses, it should be ensured that the barcode tap be affixed before the warehouse is cooled. However, if it should be necessary to work with the barcode tap at temperatures outside of the specified processing temperature, please make certain that the bonding surface as well as the barcode tap are at the processing temperature.

i **Notice!**

When working with barcode tape in curves, the barcode tape should only be partially cut at the cut mark and affixed along the curve like a fan; it must also be ensured that the barcode tape is affixed without tension (see **Figure 5-4**).

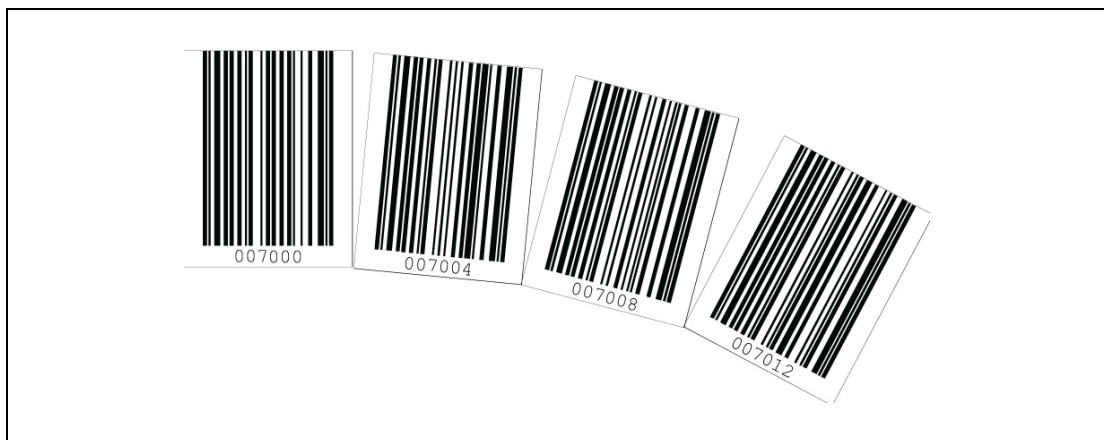

Figure 5-4: Partial cutting of the barcode tape in curves

6 Order designation

i

Notice!

Products manufactured by TR-Electronic GmbH can be ordered from any of the distributor and service addresses listed on the last page.

6.1 Read head, RH (stand-alone unit)

Explanation of the order designation

The order designation is structured according to the following scheme:

40803-1ABCD

The letters A - D represent the following device variants:

- A interface 1 = SSI (synchronous-serial)
 2 = PROFIBUS, RS485
- B extension always 0
- C extension always 0
- D option (H) 0 = without option
 1 = -30 - +40°C

Available device variants:

BE-90 RH SSI 40803-11000	Read Head SSI without option
BE-90 RH SSI + H 40803-11001	Read Head SSI with option -30 - +40°C
BE-90 RH PB 40803-12000	Read Head Profibus without option
BE-90 RH PB + H 40803-12001	Read Head Profibus with option -30 - +40°C

RH = Read Head
 SSI = Synchronous-Serial-Interface
 PB = Profibus
 H = Heating

Please indicate these designations at the order.

6.2 Connection-Unit, CU (modular hood)

Explanation of the order designation

The order designation is structured according to the following scheme:

40803-22ABC

The letters A - C represent the following device variants:

- A extension always 0
- B extension always 0
- C connection technique
 - 2 = Modular hood for BE-90 PB with 3 x M12 connectors
 - 3 = Modular hood for BE-90 PB with 5 x M12 connectors



Available connection variants:

BE-90 CU PB3	40803-22002	Hood with 3 x M12 connectors
BE-90 CU PB5	40803-22003	Hood with 5 x M12 connectors

CU = Connecting Unit
PB = PROFIBUS-Interface

Please indicate these designations at the order.

6.3 Profibus Connector, CO

Explanation of the order designation

The order designation is structured according to the following scheme:

40803-4ABCD

The letters A - D represent the following connector variants:

- A - C extension always 0
- D connector variants
 - 3 = 5 pol. Male connector for BE-90 connection unit
 - 4 = 5 pol. Female connector for BE-90 connection unit
 - 5 = 4 pol. Male connector, Profibus terminating resistor for BE-90 connection-unit
 - 6 = 5 pol. Female connector for supply voltage

Male Connector



Female Connector



Terminator



Available connector variants:

BE-90 CO MA 5P	40803-40003	Connector, shielded, M12-connector 5pol. PG9, for signal line
BE-90 CO FE 5P	40803-40004	Connector, shielded, M12-socket 5pol. PG9, for signal line
BE-90 CO TE 5P	40803-40005	Profibus terminating resistor, connector M12-B, 4pole
BE-90 CO PI 5P	40803-40006	Connector, shielded, M12-socket 5pol. PG9, for power in

CO = Connector, MA = Male, FE = Female, TE Terminator, PI = Power In

Please indicate these designations at the order.

6.4 Software, SW

Explanation of the order designation

The order designation is structured according to the following scheme:

40803-**3**ABCD

The letters A - D represent the following software variants:

- A interface 1 = SSI (Synchronous-Serial)
2 = PROFIBUS, RS485
- BCD software-no. until now "000" for both variants

Available software variants:

BE-90 SW SSI 40803-31000 SSI software variant

BE-90 SW PB 40803-32000 Profibus software variant, device master files (GSD)

SW = Software
SSI = Synchronous-Serial-Interface
PB = Profibus

Please indicate these designations at the order.

6.5 Fastening accessories, FA

The mounting unit is available for mounting the **BE-90**. It is designed for rod installation.

Explanation of the order designation

The order designation is structured according to the following scheme:

40803-5ABCD

The letters A - D represent the following mounting variants:

- A extension always 0
- B extension always 0
- C extension always 0
- D mounting element 1 = Mounting element BE-90 / Connection-Unit

Available mounting variants:

BE-90 FA-001 40803-50001 Mounting element (dove tail for round pipes) between BE-90 and connection-unit

FA = Fastener

Please indicate these designations at the order.

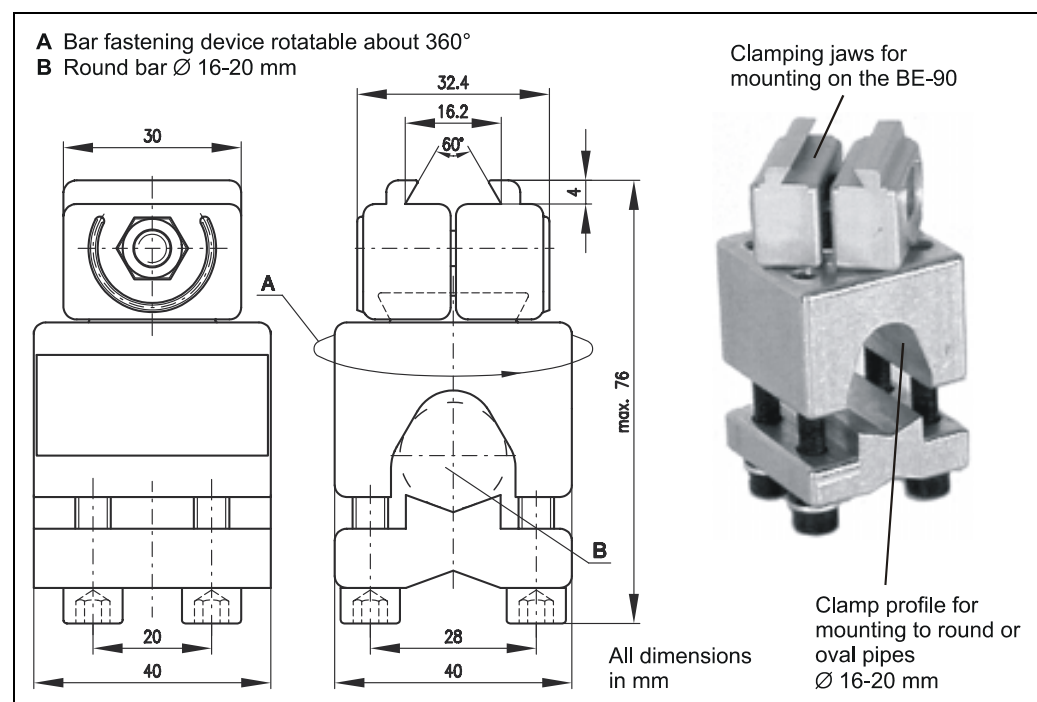

Figure 6-1: Mounting element BE-90

6.6 Special barcode band, BC

Explanation of the order designation

The order designation is structured according to the following scheme:

40803-6ABCD

The letters A - D represent the following barcode band length

- ABCD barcode band length Total length in 10 m steps
The length begins with the first meter
Example: 40803-60002 = 20 m (0 - 20 m)

Available barcode band lengths:

BE-90 BC 020	40803-60000	Barcode band, 0 - 5 m length
BE-90 BC 010	40803-60001	Barcode band, 0 - 10 m length
BE-90 BC 020	40803-60002	Barcode band, 0 - 20 m length
BE-90 BC 030	40803-60003	Barcode band, 0 - 30 m length
BE-90 BC 040	40803-60004	Barcode band, 0 - 40 m length
BE-90 BC 050	40803-60005	Barcode band, 0 - 50 m length
BE-90 BC 060	40803-60006	Barcode band, 0 - 60 m length
BE-90 BC 070	40803-60007	Barcode band, 0 - 70 m length
BE-90 BC 080	40803-60008	Barcode band, 0 - 80 m length
BE-90 BC 090	40803-60009	Barcode band, 0 - 90 m length
BE-90 BC 100	40803-60010	Barcode band, 0 - 100 m length
BE-90 BC 200	40803-60020	Barcode band, 0 - 200 m length

BC = Barcode band

Please indicate these designations at the order.

6.6.1 Special barcode band (replacement)

Must, by a damage caused, only a certain part of a barcode band to be replaced, the damaged bar code piece can be reordered. The article number BE-90 BC SA 40803-70001 must be indicated with specification of the start- and end-value of the damaged barcode band.

7 Installation

7.1 Storage, Transportation

**Attention!**

When transporting, package the device so that it is protected against collision and humidity. Optimal protection is achieved when using the original packaging. Heed the required environmental conditions specified in the technical data.

Unpacking

- *Check the packaging for any damage. If damage is found, notify the post office or shipping agent as well as the supplier.*
- *Check the delivery contents using your order and the delivery papers:*
 - delivered quantity
 - device type and model as indicated on the nameplate
 - accessories
 - operation manual with GSD file
- *Save the original packaging for later storage or shipping.*

If you have any questions concerning your shipment, please contact your supplier or your local TR-Electronic sales office.

- *Observe the local regulations regarding disposal and packaging.*

Cleaning

- *Clean the glass window of the BE-90 PB with a soft cloth before mounting. Remove all packaging remains, e.g. carton fibres or Styrofoam balls.*

**Attention!**

Do not use aggressive cleaning agents such as thinner or acetone for cleaning the device and the barcode band.

7.2 Mounting

Accessories

For installation a mounting system is available. It may be ordered separately from TR-Electronic. For order numbers, see chapter 6.5 "Fastening accessories, FA" on page 25.

Mounting the BE-90 PB

There are two basic types of mounting arrangements for the **BE-90 PB**.

- using the dovetail groove and the corresponding mounting accessories (see Figure 7-1)
- using the fastening threads on the backside of the devices (chapter 4.5)

Mounting Example BE-90 PB

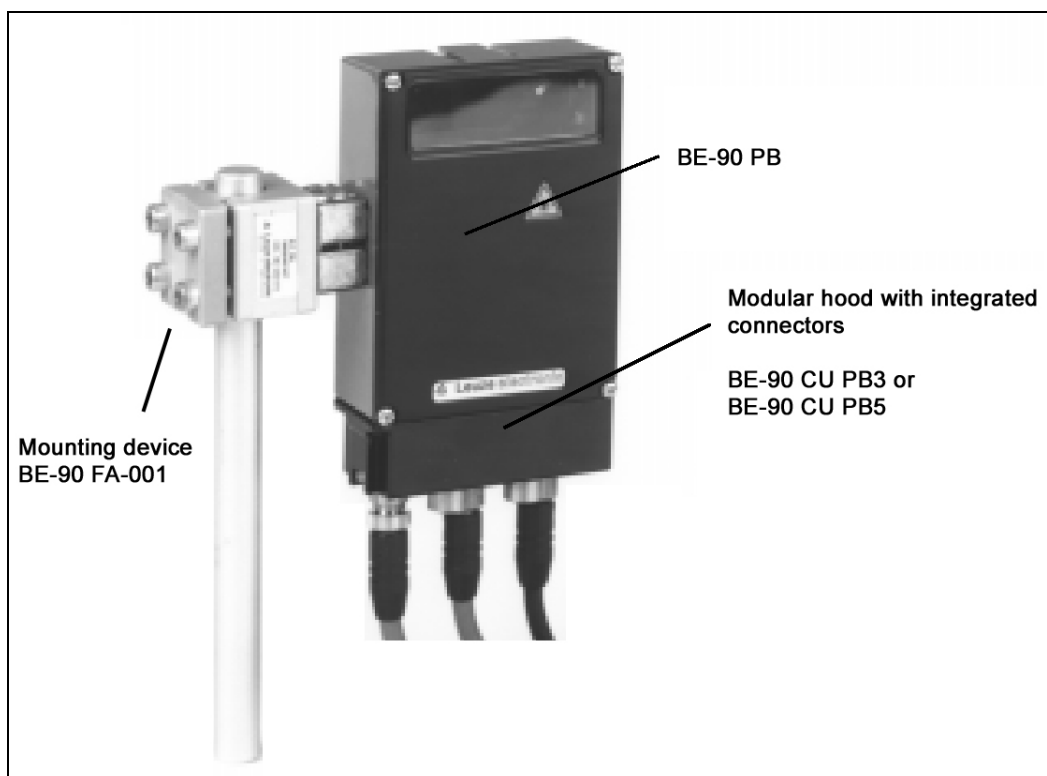

Figure 7-1: Mounting Example BE-90 PB

7.2.1 Device arrangement

Selecting a Mounting Location

In order to select the right mounting location, several factors must be considered:

- The scanning range determined from the scanning curve must be adhered to at all locations at which a position determination is to be made
- The BE-90 should be mounted inclined 10° from vertical towards the barcode band to ensure that the positioning results are reliably obtained even if the barcode band is soiled.

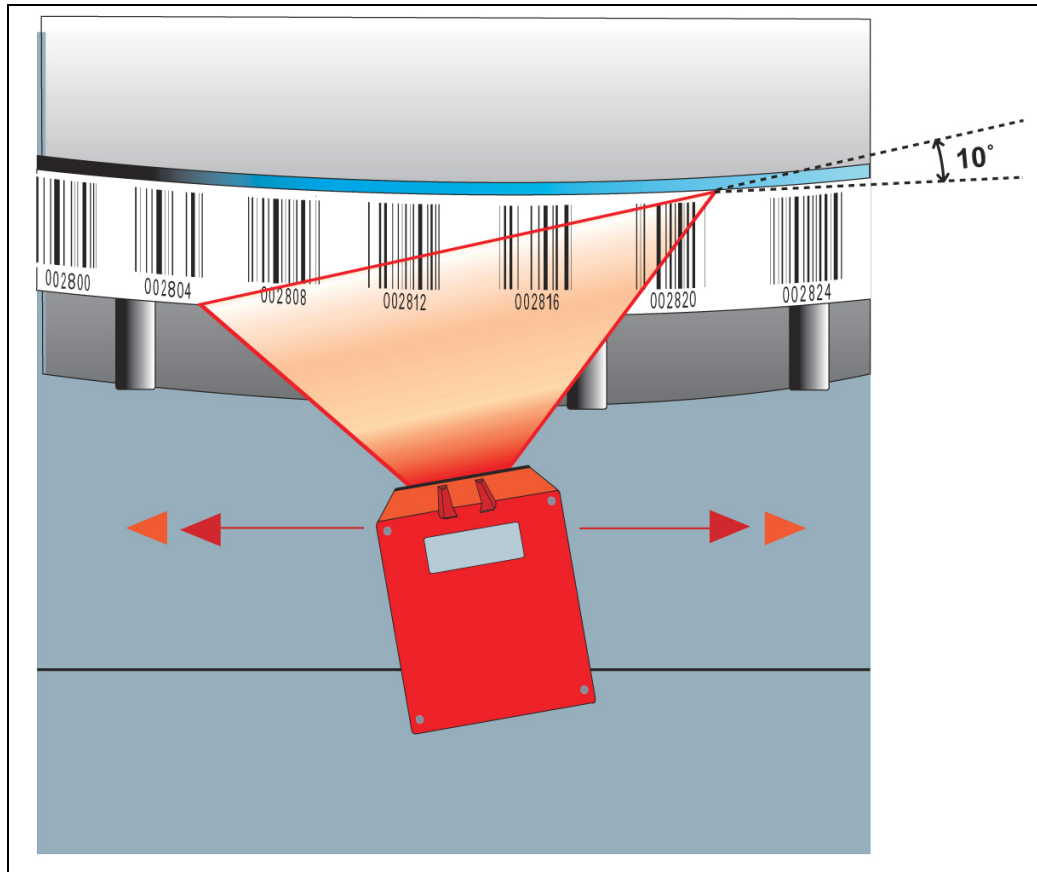

Figure 7-2: Device Arrangement to the Barcode Band



Notice!

The best functionality is obtained when:

- the BE-90 is guided parallel to the band
- the permitted working range is not exited



Notice!

On the BE-90 PB, the beam is not emitted perpendicular to the cover of the housing, but with an angle of 10° towards the top. This angle is intended to prevent total reflection on the barcode band.

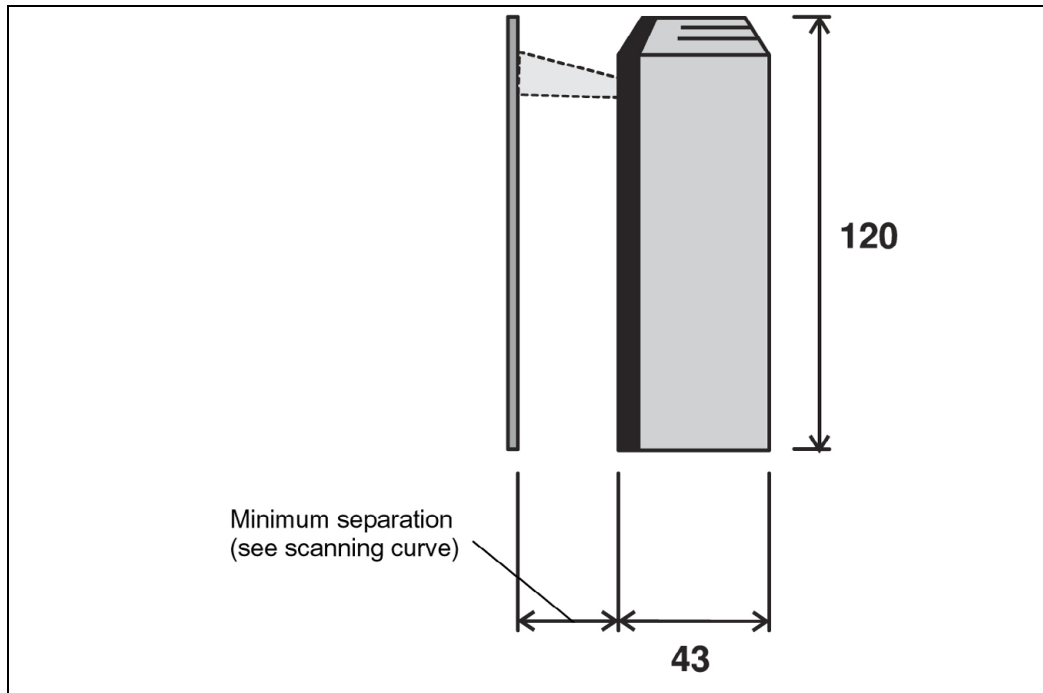

Figure 7-3: Beam outlet on the BE-90 PB

Mounting Location

- *When selecting a mounting location, pay attention to*
 - maintaining the required environmental conditions (humidity, temperature),
 - possible soiling of the reading window due to liquids, abrasion by boxes, or packaging material residues.
 - lowest possible chance of damage to the BE-90 PB by mechanical collision or jammed parts.

Application Example

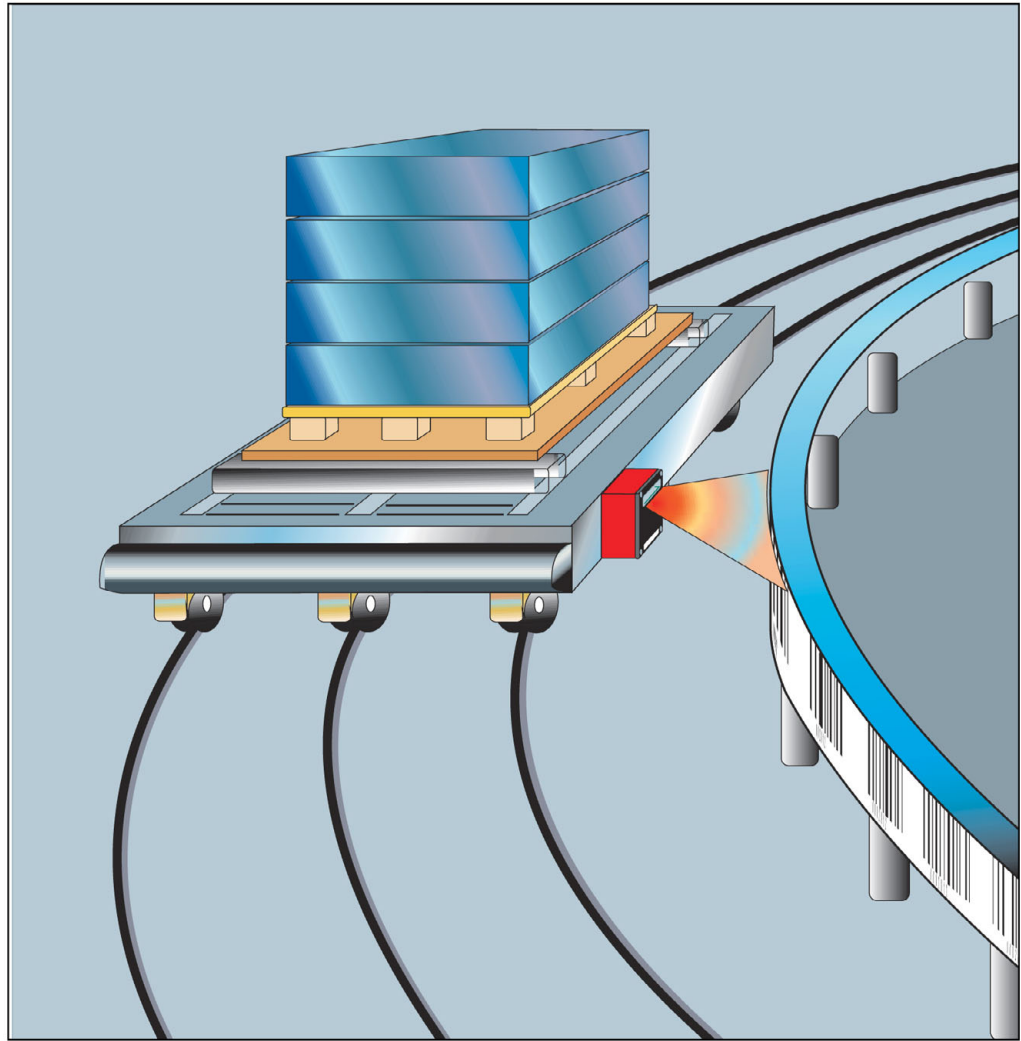

Figure 7-4: Application Example

7.3 Address setting

In the modular hoods with integrated connectors BE-90 CU PB3 and BE-90 CU PB5, the Profibus address can be set via two rotary switches and one slide switch. The address switches are positioned as follows.

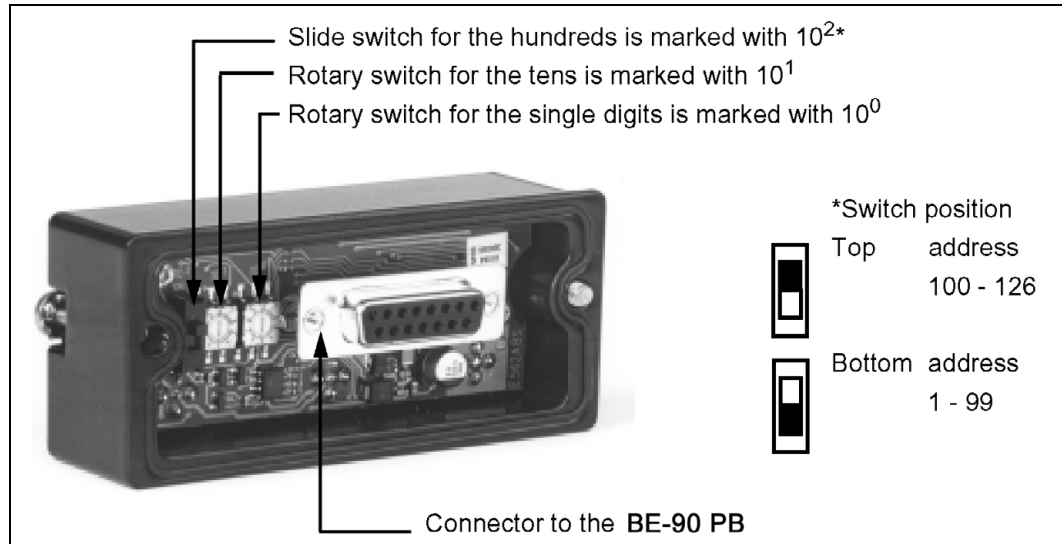

Figure 7-5: View of the Inside of the BE-90 CU

7.4 Connection



Attention!

Never open the device yourself, as this may compromise protection class IP 65.

Before connecting the device, be sure that the supply voltage agrees with the value printed on the nameplate.

Connection of the device and maintenance work while under voltage must only be carried out by a qualified electrician.

The power supply unit for the generation of the supply voltage for the BE-90 PB and the respective connector units must have a secure electrical insulation through double insulation and safety transformers according to DIN VDE 0551 (IEC 742).

Be sure that the earthing conductor is connected correctly. Error-free operation is only guaranteed when the device is properly earthed.

If faults cannot be corrected, the device should be removed from operation and protected against possible use.

7.4.1 Connecting the BE-90 PB

Connections BE-90 CU PB3 / BE-90 CU PB5

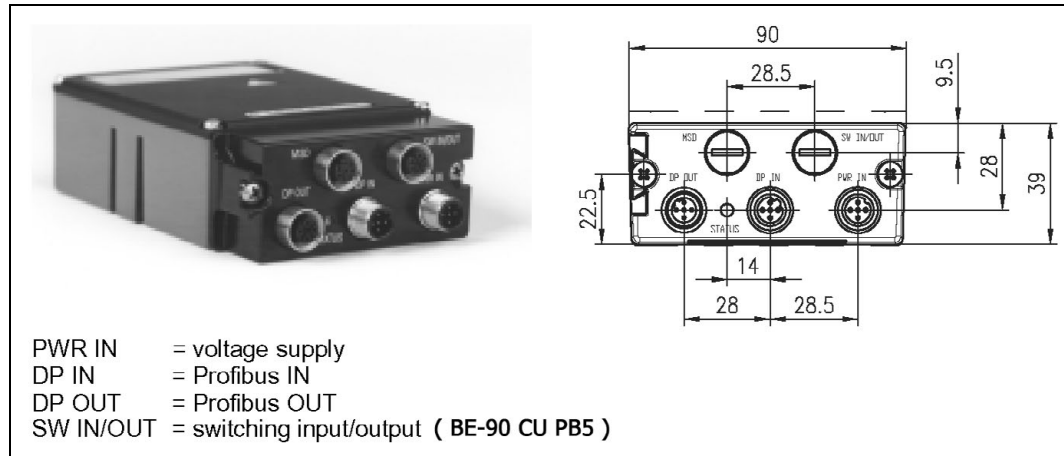

Figure 7-6: Connection assignment of the BE-90 PB with BE-90 CU PB3 / BE-90 CU PB5

Wiring Description PWR IN (Voltage Supply)

Pin 1	VIN	10 ... 30 VDC voltage supply
Pin 2	SW OUT	Switching output
Pin 3	GND IN	GND for voltage supply
Pin 4	SW IN	Switching input
Pin 5	PE	Protected Earth

Table 7-1: Pin Assignment PWR IN



Attention!

It is absolutely necessary to connect the protective conductor, since all electrical interference (EM pick-up) is discharged via the protective conductor connection.

Connection of the protective conductor PE

BE-90 PB including hood with integrated connectors BE-90 CU PB3/BE-90 CU PB5:
 Connect PE to pin 5 of the hood socket PWR IN for the voltage supply!

Connection Description SW IN/OUT (Switching Input/Output)

Pin 1	V OUT	24 V voltage supply for the sensors
Pin 2	SW OUT	Switching output
Pin 3	GND OUT	GND for the sensors
Pin 4	SW IN	Switching input
Pin 5	PE	Protected Earth

Table 7-2: Pin Assignment SW IN/OUT

You can configure the switching input and output according to your requirements. Please refer to Figure 7-7. If you use a sensor with a standard M12 connector, then please note the following:

Attention!

Only use sensors without switching output on pin 2 or sensor wiring configured without pin 2, as the switching output is not protected against feedback. For example, having the inverted sensor output incident on pin 2 leads to erroneous behaviour of the switching output.

Connection Description Profibus IN/OUT

Pin 1	VCC	5 V for bus termination
Pin 2	N	N or A line of the Profibus
Pin 3	GND	Ground for bus termination
Pin 4	P	P or B line of the Profibus
Pin 5	PE	protective conductor

Table 7-3: Pin Assignment DP IN/OUT

7.4.2 Connection of switching inputs and outputs

The BE-90 PB is provided with a switching input and a switching output. The connection of the switching inputs and outputs is carried out according to Figure 7-7.

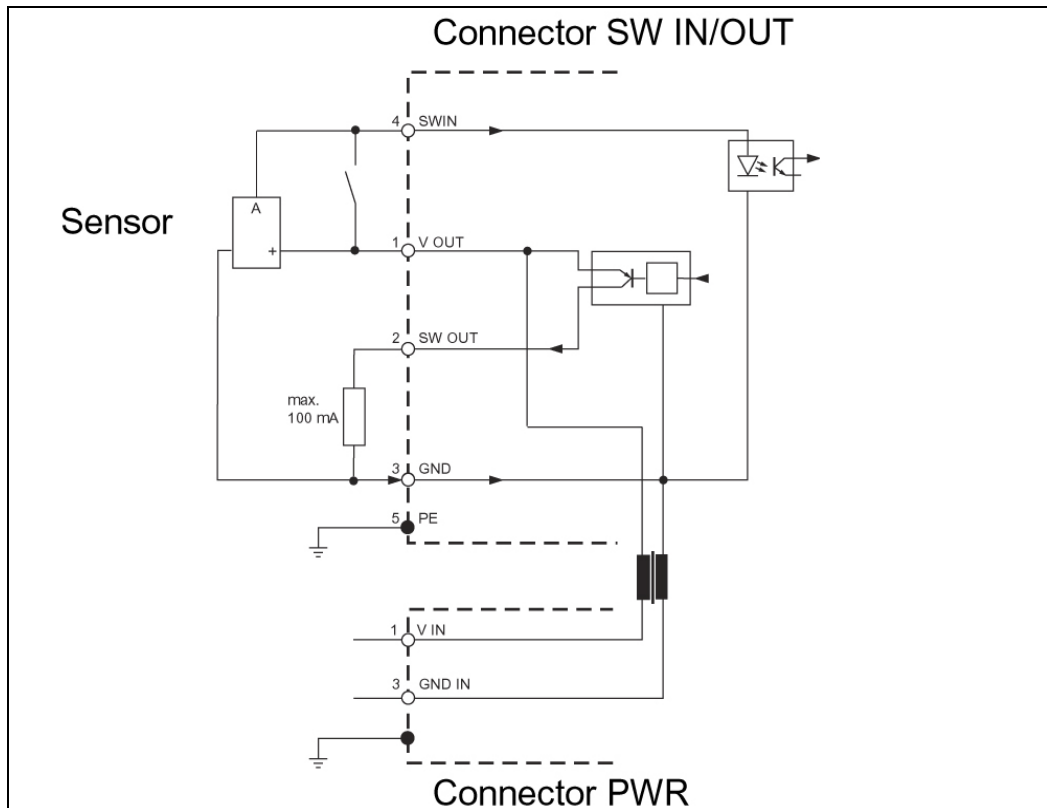

Figure 7-7: Connection Diagram Switching Inputs and Outputs BE-90 PB

Switching input

In the standard setting, you can reset output of the positioning data (preset) via the switching input connection SWIN by connecting SWIN (pin 4) and VOUT (pin 1).

Switching output

The switching output connection between SWOUT (pin 2) and GND (pin 3) is normally open. In the standard setting, SWOUT is closed in the case of a positioning error.



Notice!

You can configure the switching inputs and outputs according to your requirements by using the modules 7 (switching input) and 8 (switching output).

7.5 Disassembling, Packing, Disposing

Repacking

For later reuse, the device is to be packed so that it is protected against shocks and dampness. Optimal protection is achieved when using the original packaging.



Notice!

Electrical scrap is a special waste product! Observe the locally applicable regulations regarding disposal of the product.

8 Profibus

8.1 General information

The BE-90 PB with BE-90 CU PB3/BE-90 CU PB5 was developed as a Profibus device. The functionality of the device is defined via parameter sets which are clustered in modules. These modules are included in a GSD file, which is supplied as an integral part of the device. By using a user-specific project tool, such as, e.g., Simatic Manager for the programmable logic control by Siemens, the required modules are integrated into a project during commissioning and its settings and parameters are adjusted accordingly. These modules are provided by the GSD file.

All input and output modules described in this documentation are described from the controller's perspective:

- Input data arrives at the controller
- Output data is sent out by the controller.

8.1.1 GSD File

The GSD file is on the Software/Support CD:
Order number: 490-01001, Soft-No.: 490-00406.

This file stores all the data required for the operation of the BE-90 PB. This data consists of device parameters required for operation of the BE-90 PB, Profibus operation parameters, and the definition of the control and status bits. If parameters are changed in the project, for example, these changes are stored in the project, not in the GSD file.

The GSD file is a certified part of the device and must not be changed manually. The file is not changed by the system either.

8.2 Structure of the project modules

In the current version, a total of 26 modules are available for use. The modules may be included into the project according to requirements and application.

The modules fall into the following categories:

- Parameter module for the scanner configuration
- Status or control modules that influence the input and output data.
- Modules that may include both parameters and control or status information.

The category of each module is marked with a cross in the overview.



Notice!

At least one module must be activated to permit operation of the device at the Profibus DP.

8.2.1 Overview of the project modules



Notice!

Inputs and outputs are described from the perspective of the Profibus master.

Module Nr.	Name of the module	Description	Parameter	Output data	Input data
1	Module 1: Position value	Position value	X		X
2	Module 2: Resolution	Setting of position value resolution	X		
3	Module 3: Static preset	Value setting for static preset function	X	X	
4	Module 4: Dynamic preset	Value setting for dynamic preset function		X	
5	Module 5: Offset value	Value setting for offset value	X		
6	Module 6: Scaling	Value setting for position value scaling	X		
7	Module 7: Switching input	Specification of switching input	X		X
8	Module 8: Switching output	Specification of switching output	X	X	
9	Module 9: Controller	Controls start of measuring process	X	X	X
10	Module 10: Measurement value acquisition	Defines min. start of measurement and max. end of measurement	X		
11	Module 11: Measurement value processing	Parameter for internal processing of measurement value	X	X	
12	Module 12: Status	BE-90 status at Profibus			X
13	Module 13: Min – Max position	Activation of function used to determine min/max values	X	X	
14	Module 14: Static limit value 1	Static preset of position 1; a function is triggered when position is reached	X		
15	Module 15: Static limit value 2	Static preset of position 2; a function is triggered when position is reached	X		
16	Module 16: Dynamic limit value 1	Dynamic preset of position 1; a function is triggered when position is reached	X	X	
17	Module 17: Dynamic limit value 2	Dynamic preset of position 2; a function is triggered when position is reached	X	X	
18	Module 18: Measuring error tolerance	Period of time in which a measuring error will be ignored	X		
19	Module 19: Service	Reset to default values		X	X

20	Module 20: Velocity	Output of the current velocity			X
21	Module 21: Velocity parameters	Parameter setting of the velocity measuring	X		
22	Module 22: Velocity measurement control	Controlling of the temporary sequence of the velocity measuring	X	X	X
23	Module 23: Velocity measurement status	Status information of the velocity measuring			X
24	Module 24: Min/Max velocity	Output of the min. and max. velocity value			X
25	Module 25: Static velocity limit values	Presetting of the velocity limit values via parameter	X		
26	Module 26: Dynamic velocity limit value	Presetting of the dynamic velocity limit value via output data		X	

Table 8-1: Overview of the project modules

8.2.2 Module 1: Position value

Description

Output of the current position value without additional information, i.e. independent of the parameterised output formatting.

Parameter

Parameter	Description	Rel. address	Data Type	Value Range	Standard	Unit
Sign	Output mode for sign	0	UNSIGNED 8	0: Binary representation 1: Sign with value	0	-

Table 8-2: Parameters for module 1

Parameter length: 1 byte

Input Data

Input Data	Description	Address	Data Type	Value Range	Init Value	Unit
Position	Current position	0	SIGNED 32	-10 000 000 ... 10 000 000	0	Scaled

Table 8-3: Input Data for module 1

Input data length: 4 bytes consistently

8.2.3 Module 2: Resolution

Description

The resolution function defines the resolution for the position values and performs a rounding correction.

Parameter

Parameter	Description	Rel. address	Data Type	Value Range	Standard	Unit
Resolution	The Parameter defines the resolution for the position	0	UNSIGNED 8	1: 0.01 2: 0.1 3: 1 4: 10 5: 100 6: 1000	3	mm

Table 8-4: Parameters for module 2

Parameter length: 1 byte

Input Data

none

Output Data

none

8.2.4 Module 3: Static preset

Description

This module is used to preset a value which the BE-90 is to output after an event (e.g. a 24V level at the switching input or an event caused by a bit being set in the output data) has occurred. The value is stored permanently in the BE-90.

Parameter

Parameter	Description	Rel. address	Data Type	Value Range	Standard	Unit
Pre-set value	New position value after preset	0	UNSIGNED 32	0 ... 10 000 000	0	mm

Table 8-5: Parameters for module 3

Parameter length: 4 bytes

Input Data

none

Output Data

Output Data	Description	Address	Data Type	Value Range	Unit
Preset teach	Read-in of preset values	0.0	Byte	0 = none 0->1 = Teach	-
Preset reset	Resetting to default values, deactivation of preset function	0.1	Byte	0 = none 0>1 = reset	-

Table 8-6: Output data for module 4
8.2.5 Module 4: Dynamic preset
Description

This module is used to preset a value which the BE-90 is to output after an event (e.g. a 24V level at the switching input) has occurred. The value is stored permanently in the BE-90.

The preset value is defined using output data from the Profibus master.

Parameter

none

Input Data

none

Output Data

Output Data	Description	Address	Data Type	Value Range	Init Value	Unit
Preset-Teach	Read-in of preset values	0.0	Byte	0 = none 0->1 = Teach	0	0
Preset-Reset	Resetting to default values, switchover of preset function	0.1	Byte	0 = none 0>1 = Reset	0	-
Pres-set value	New position value after preset	1	UNSIGNED 32	0 10 000 000	0	mm

Table 8-7: Output data for module 4

Output data length: 4 bytes consistently

8.2.6 Module 5: Offset value

Description

The start value function adds an offset value to the scaled position value.

Parameter

Parameter	Description	Rel. address	Data Type	Value Range	Standard	Unit
Offset value	Offset value added to position value	0	SIGNED 32	-10 000 000 ... 10 000 000	0	Scaled units

Table 8-8: Parameters for module 5

Parameter length: 4 bytes

Input Data

none

Output Data

none

8.2.7 Module 6: Scaling

Description

The scaling function allows the position values to be converted to any unit of measurement. To do this, the position is multiplied by the scaling factor.

Parameter

Parameter	Description	Rel. address	Data Type	Value Range	Standard	Unit
Scaling factor	Scaling factor used to convert position values	0	UNSIGNED 16	0-65535	1000	Per thousand

Table 8-9: Parameters for module 6

Parameter length: 2 bytes

Input Data

none

Output Data

none

8.2.8 Module 7: Switching input

Description

The module defines the mode of operation of the digital switching input.

Parameter

Parameter	Description	Address	Data Type	Value Range	Standard	Unit
Inversion	The parameter defines the logic of the incident signal. In case of an inversion, an external HIGH level is interpreted internally as a LOW level.	0	UNSIGNED 8	0: No 1: Yes	0	-
Mode	The parameter can be used to control the processing of the switching input	1	UNSIGNED 8	0: Off 1: On	1	-
De-bouncing time	The parameter defines a de-bouncing time which is implemented in software	2	UNSIGNED 8	0 ... 255	5	1 ms
Start-up delay	The parameter influences the timing during switch-on	3	UNSIGNED 16	0 ... 65535	0	1 ms
Minimum switch-on time	The parameter defines a minimum time period before the signal is reset.	5	UNSIGNED 16	0 ... 65535	0	1 ms
Switch-off delay	The parameter defines a time delay for the signal during switch-off	7	UNSIGNED 16	0 ... 65535	0	1 ms
Function	The parameter specifies the function which is to be activated or deactivated by a change of state in the signal.	9	UNSIGNED 8	0: no function 4: Preset teach 5: Min/Max Reset 6: Hold Set 7: Measurement start 9: Measurement Stop 10: Limit value 1 teach 11: Limit value 2 teach	4	-

Table 8-10: Parameters for module 7

Parameter length: 10 bytes

Input Data

Input Data	Description	Address	Data Type	Value Range	Init Value	Unit
State	State of the signal of the switching input 1	0.0	Bit	0.1	0	-

Table 8-11: Input data for module 7

Input data length: 1 byte consistently

Output Data

none

8.2.9 Module 8: Switching output**Description**

The module defines the mode of operation of the digital switching output.

Parameter

Parameter	Description	Ad- dress	Data Type	Value Range	Standard	Unit
DC bias level	The parameter defines the DC bias level of the switching output	0	UNSIGNED 8	0: LOW (OV) 1: HIGH (+Ub)	0	-
Switch on time	The parameter defines the switch-on time period for the switching output. If the value is 0, the signal is static.	2	UNSIGNED 16	0 ... 1300	400	1 ms
Switch on function	The parameter specifies the events which can set the switching output.	4	Bits	Respectively 0: Off 1: On		
	Limit value 1 reached	4.2			0	
	Limit value 1 not reached	4.3			0	
	Measurement value outside measurement value range	4.4			0	
	Measurement value inside measurement value range	4.5			0	
	Limit value 2 reached	4.6			0	
	Limit value 2 not reached	4.7			0	
	After erroneous measurement	4.10			1	
	After successful measurement	4.11			0	
	PROFIBUS positive edge	4.12			0	
PROFIBUS negative edge	4.13	0				

Table 8-12: Parameters for module 8

Parameter	Description	Address	Data Type	Value Range	Standard	Unit
Switch off function	The parameter specifies the events which can reset the switching output.	6	Bit	Respectively 0: Off 1: On		
	Limit value 1 reached	6.2			0	
	Limit value 1 not reached	6.3			0	
	Measurement value outside measurement value range	6.4			0	
	Measurement value inside measurement value range	6.5			0	
	Limit value 2 reached	6.6			0	
	Limit value 2 not reached	6.7			0	
	After erroneous measurement	6.10			0	
	After successful measurement	6.11			1	
	PROFIBUS positive edge	6.12			0	
	PROFIBUS negative edge	6.13			0	

Table 7-12: Parameters for module 8

Parameter length: 8 bytes

Input Data

none

Output Data

Output Data	Description	Address	Data Type	Value Range	Init Value	Unit
Switching output	Signal used to set status of switching output 1. Requirement: PROFIBUS edge is parameterised	0.0	Bit	0->1: positive edge 1->0: negative edge	-	

Table 8-13: Output data for module 8

Output data length: 1 byte consistently

8.2.10 Module 9: Controller

Description

The position controller schedules the timing of the position calculation by controlling the decoder and router using the output of the position values.

The controller used to calculate the position receives the incoming external signals (e.g. switching input or commands) and uses them to control the calculation process. Using parameters, it determines who is allowed to influence the states. The controller constitutes a dedicated task in a state machine.

Parameter

Parameter	Description	Rel. address	Data Type	Value Range	Standard	Unit
Measurement start mode	The start mode determines when the position measurement is started.	0	UNSIGNED 8	0: no function 1: after initialisation 2: After start event as result of command, switching input or signal from Profibus master	1	-
Measurement stop mode	The stop mode determines when the position measurement is stopped	1	UNSIGNED 8	0: no function 1: valid measurement result 2: After certain time 3: After certain time with retrigger function as result of command 4: After stop event as result of command or status from switching input 5: Error status	4	-
Pos_Control_Stop_Timeout	Time for stop timeout	2	UNSIGNED 16	0 ... 65535	1 0000	ms

Table 8-14: Parameters for module 9

Parameter length: 4 bytes

Input Data

Input Data	Description	Address	Data Type	Value Range	Init Value	Unit
Pos_Control_State	Status of position controller	0	UNSIGNED 8	0: Init 1: Idle 2: Measure 3: Polling	0	-

Table 8-15: Input data for module 9

Input data length: 1 byte consistently

Output Data

Output Data	Description	Address	Data Type	Value Range	Init Value	Unit
Pos_Start_Event	Event which starts position measurement	0.0	Bit	0: no change 0 ->1: start	0	-
Pos_Stop_Event	Event which stops position measurement	0.1	Bit	0: no change 0 ->1: stop	0	-

Table 8-16: Output data for module 9

Output data length: 1 byte consistently

8.2.11 Module 10: Measurement value acquisition

Description

The measurement value acquisition module analyses all bar codes in the scan and provides a list of raw position data for the scan.

Parameter

Parameter	Description	Rel. Address	Data Type	Value Range-	Standard	Unit
Max. measurement length	Maximum permitted measurement length	0	UNSIGNED 32	0h ... 7FFF FFFFh	10 000 000	mm
Min. measurement length	Minimum permitted measurement length	4	UNSIGNED 32	0h ... 7FFF FFFFh	0	mm

Table 8-17: Parameters for module 10

Parameter length: 8 bytes

Input Data

none

Output Data

none

8.2.12 Module 11: Measurement value processing

Description

The measurement value processing module integrates the acquired raw position data to form a position value.

Parameter

Parameter	Description	Rel. Address	Data Type	Value Range	Standard	Unit
Integration depth	Number of consecutive scans which are to be used for position determination	0	UNSIGNED 8	0 ... 255	8	Measurements

Table 8-18: Parameters for module 11

Parameter length: 2 bytes

Input Data

none

Output Data

Output Data	Description	Address	Data Type	Value Range	Init Value	Unit
Count direction	Count direction for position calculation	0.0	Bit	0: normal 1: inverse	0	-

Table 8-19: Output data for module 11

Output data length: 1 byte consistently

8.2.13 Module 12: Status

Description

This module defines various items of status information from the BE-90 PB.

Parameter

none

Input Data

Input Data	Description	Ad- dress	Data Type	Value Range	Init Value	Unit
Measurement error	[Measurement Value Processing] Indicates that no valid integration value could be determined.	0.0	Bit	0 : OK 1 : Integration error	0	-
Range status	[Measurement Value Acquisition] Indicates that measurement range has been exceeded	0.1	Bit	0 : OK in the measurement range 1 : Measurement range exceeded	0	-
Limit value status 1	[Measurement Value Monitoring] Indicates that limit value 1 has been exceeded or under-shot	0.4	Bit	0: Not exceeded 1: Exceeded	0	-
Limit value status 2	[Measurement Value Monitoring] Indicates that limit value 2 has been exceeded or under-shot	0.5	Bit	0: Not exceeded 1: Exceeded	0	-

Table 8-20: Input data for module 12

Input data length: 1 byte consistently

Output Data

none

8.2.14 Module 13: Min – Max position

Description

The Min / Max position function monitors the position value and transfers the maximum / minimum value to the Profibus master.

The acquisition time can be adjusted by means of two different modes. The absolute value mode collects all values occurring since the start of measurement or since a reset. The sliding value mode only collects extreme values for the period defined in a parameter.

Parameter

Parameter	Description	Rel. Address	Data Type	Value Range	Standard	Unit
MinMax-Mode	Parameter activates Min/Max evaluation function	0	UNSIGNED 8	0: OFF 1: All measurement values 2: Only in measurement value window	0	-
MinMax period	Validity period for Min-Max values	1	UNSIGNED 8	0 ... 255	10	Measurements

Table 8-21: Parameters for module 13

Parameter length: 2 bytes

Input Data

Input Data	Description	Address	Data Type	Value Range	Init Value	Unit
Min. position	Minimum position for detected period	0	SIGNED 32	-10 000 000 ... 10 000 000	0	Scaled unit
Max. position	Maximum position for detected period	4	SIGNED 32	-10 000 000 ... 10 000 000	0	Scaled unit

Table 8-22: Input data for module 13

Input data length: 8 bytes consistently

Output Data

Output Data	Description	Address	Data Type	Value Range	Init Value	Unit
MinMax-reset	Signal for resetting extreme values	0	Bit	0: nothing 0->1: Reset	0	-

Table 8-23: Output data for module 13

Output data length: 8 bytes consistently

8.2.15 Module 14: Static limit value 1

Description

The limit value function compares the position value with a position stored during parameterisation. If the limit value is exceeded or undershot, an action is triggered and a status is set.

Parameter

Parameter	Description	Rel. address	Data Type	Value Range	Standard	Unit
Limit value mode 1	Parameter activates limit value checking	0	UNSIGNED 8	0: Off 1: On	0	-
Switching mode 1	Condition for signal change	1	UNSIGNED 8	0: Exceeded 1: Undershot	0	
Hysteresis 1	Rel. offset of switching point	2	UNSIGNED 16	0-65535	0	mm
Limit value 1	Limit value which is compared to current output position	4	SIGNED 32	-10 000 000 ... 10 000 000	0	mm

Table 8-24: Parameters for module 14

Parameter length: 8 bytes

Input Data

none

Output Data

none

8.2.16 Module 15: Static limit value 2
Description

The limit value function compares the position value with a position stored during parameterisation. If the limit value is exceeded or undershot, an action is triggered and a status is set.

Parameter

Parameter	Description	Rel. Address	Data Type	Value Range	Standard	Unit
Limit value Mode 2	Parameter activates limit value checking	0	UNSIGNED 8	0: Off 1: On	0	-
Switching mode 2	Condition for signal change	1	UNSIGNED 8	0: Exceeded 1: Undershot	0	
Hysteresis 2	Rel. offset of switching point	2	UNSIGNED 16	0-65535	0	mm
Limit value 2	Limit value which is compared to current output position	4	SIGNED 32	-10 000 000 ... 10 000 000	0	mm

Table 8-25: Parameters for module 15

Parameter length: 8 bytes

Input Data

none

Output Data

none

8.2.17 Module 16: Dynamic limit value 1

Description

The limit value function compares the position value with a stored position. If the limit value is exceeded or undershot, an action is triggered and a status is set.

The limit value is defined using output data from the Profibus master.

Parameter

Parameter	Description	Rel. Address	Data Type	Value Range	Standard	Unit
Limit value mode 1	Parameter activates limit value checking	0	UNSIGNED 8	0: Off 1: On	0	-
Switching mode 1	Condition for signal change	1	UNSIGNED 8	0: Exceeded 1: Undershot	0	
Hysteresis1	Rel. offset of switching point	2	UNSIGNED 16	0-65535	0	mm

Table 8-26: Parameters for module 16

Parameter length: 4 bytes

Input Data

none

Output Data

Output Data	Description	Address	Data Type	Value Range	Init Value	Unit
Limit value 1	Limit value which is compared to current output position	0	SIGNED 32	-10 000 000... 10 000 000	0	mm

Table 8-27: Output data for module 16

Output data length: 4 bytes consistently

8.2.18 Module 17: Dynamic limit value 2

Description

The limit value function compares the position value with a stored position. If the limit value is exceeded or undershot, an action is triggered and a status is set.

The limit value is defined using output data from the Profibus master.

Parameter

Parameter	Description	Rel. address	Data Type	Value Range	Standard	Unit
Limit value mode 2	Parameter activates limit value checking.	0	UNSIGNED 8	0: Off 1: On	0	-
Switching Mode 2	Condition for signal change	1	UNSIGNED 8	0: Exceeded 1: Undershot	0	
Hysteresis 2	Rel. offset of switching point	2	UNSIGNED 16	0-65535	0	mm

Table 8-28: Parameters for module 17

Parameter length: 4 bytes

Input Data

none

Output Data

Output Data	Description	Address	Data Type	Value Range	Init Value	Unit
Limit value2	Limit value which is compared to current output position	0	SIGNED 32	-10 000 000... 10 000 000	0	mm

Table 8-29: Output data for module 17

Output data length: 4 bytes consistently

8.2.19 Module 18: Measuring error tolerance

Description

The measuring error tolerance function is used to configure a time which results in an extended output of the last position value (module 1) in the event of an error. If the position value changes momentarily to zero, e.g. due to a brief interruption of the laser beam, soiling of the barcode tape or other short-term disturbances, the BE-90 PB transmits the last valid position value.

If the error disappears within the configured time, the control notices nothing or only a small change in the position value. The availability of the system is thereby ensured. No new values are delivered by the BE-90 PB, however, for a period of time extending up to the configured tolerance time. With the "delay error output" parameter, an integration error (corresponds to a missing position value) can be signalled immediately or after the tolerance time has elapsed.

Parameter

Parameter	Description	Rel. Address	Data Type	Value Range	Standard	Unit
Position tolerance time	Specifies the time for the output of the last position value following an error	0	UNSIGNED 16	0...65535	50	1 ms
Delay error output	Delays the output of an integration error by the configured tolerance time	2	UNSIGNED 8	0: No, error delay deactivated 1: Yes, error delay activated	1	-

Table 8-30: Parameters for module 18

Parameter length: 3 bytes

Input Data

none

Output Data

none

8.2.20 Module 19: Service

Description

The "service" function is used to reset the parameter set of the BE-90 PB to default settings. This reset only occurs directly in the BE-90 PB. After the reset function has been activated, the device carries out a reset and is freshly configured on the PROFIBUS. This results in the reactivation of all modules and parameter settings selected in the PROFIBUS project.

Parameter

none

Input Data

Input Data	Description	Address	Data Type	Value Range	Init Value	Unit
Status byte	Shows the state of the reset to factory settings	0	UNSIGNED 8	0x00: Not active or successfully concluded 0xFF: Reset active 0xF1: EEPROM access error	0x00	-

Table 8-31: Input data for module 19

Input data length: 1 byte

Output Data

Output Data	Description	Address	Data Type	Value Range	Init Value	Unit
Factory settings	Reset of parameters to factory settings	0.0	Bit	0 -> 1: Reset parameters 1 -> 0: Standard operation	0	-

Table 8-32: Output data for module 19

Output data length: 1 byte



Notice!

The preset function (module 3) must be rethought following a reset.

8.2.21 Module 20: Velocity

Description

Outputs the current velocity with the configured resolution and the desired scaling factor. In order for the velocity to be calculated in the BE-90 PB and output in this module, module 22 (Velocity measurement control) must also be activated in the PROFIBUS project.

Parameter

none

Input Data

Input Data	Description	Address	Data Type	Value Range	Init Value	Unit
Velocity	Current velocity	0	UNSIGNED 32	0 ... 10'000'000	0	scaled

Table 8-33: Input data for module 20

Input data length: 4 bytes consistently



Notice!

The scaling of the position value has no effect on the scaling or output of the velocity.

The direction of movement of the BE-90 PB is displayed in module 23 "Velocity measurement status" under "Direction of movement", see page 61.

Output Data

none

8.2.22 Module 21: Velocity parameters

Description

The velocity parameter influences the fundamental method of operation and output of the velocity measurement. The resolution, scaling, integration depth and error tolerance for the velocity measurement can be defined.

The resolution function defines the resolution for the velocity value (module 20). The scaling function allows the velocity values to be converted to any unit of measurement. To do this, the velocity value (module 20) is multiplied by the scaling factor. The velocity integration depth parameter averages the selected number of velocity values to produce the velocity output in module 20.

The velocity tolerance time function is used to configure a time which results in an extended output of the last velocity (module 20) in the event of an error. If the speed could not be calculated momentarily, e.g. due to a brief interruption of the scanning beam, soiling of the barcode tape or other short-term disturbances, the BE-90 PB transmits the last valid velocity. If the error disappears within the configured time, the control notices nothing or only a small change in the velocity value. The availability of the system is thereby ensured.

The "delay velocity error output" parameter can be used to signal a velocity error with bit 0.0 either immediately or after the velocity tolerance time in module 23 has elapsed. If the error persists after the tolerance time has elapsed, a velocity value of zero is output.

Parameter

Parameter	Description	Rel. Address	Data Type	Value Range	Standard	Unit
Velocity resolution	The parameter specifies the resolution for the velocity value	0	UNSIGNED 8	1 10 100 1'000	1	mm/s
Velocity scaling factor	Scaling factor used to convert the velocity	1	UNSIGNED 16	0 ... 65'535	1000	Per thousand
Velocity integration depth	Number of consecutive measurements which are to be used for velocity determination	3	UNSIGNED 8	0 ... 255	8	Measurements
Velocity tolerance time	Specifies the time for the display of the last velocity following an error	4	UNSIGNED 16	0 ... 65'535	50	1 ms
Delay velocity error output	Delays the output of a velocity error by the configured tolerance time	6	UNSIGNED 8	0: No, error delay deactivated 1: Yes, error delay activated	1	-

Table 8-34: Parameters for module 21

Parameter length: 7 bytes

Input Data

none

Output Data

none

8.2.23 Module 22: Velocity measurement control

Description

The control manages the timing of the velocity measurement by starting or stopping the measurement function. Control is performed depending on certain events such as the switching input, time functions or PROFIBUS output bits. Using parameters, it determines the events which influence the states.

Parameter

Parameter	Description	Rel. Address	Data Type	Value Range	Standard	Unit
Velocity measurement start mode	The start mode determines by which event the velocity measurement is started	0	UNSIGNED 8	0: Deactivated 1: After initialisation 2: Following event: either by the switching input or by a signal from the PROFIBUS master	0	-
Velocity measurement stop mode	The stop mode determines after which event the velocity measurement is stopped	1	UNSIGNED 8	0: Deactivated 1: By an error 2: By a stop event: either by output bit 0.1 or by the switching input function	0	-

Table 8-35: Parameters for module 22

Parameter length: 2 bytes

Input Data

Input Data	Description	Address	Data Type	Value Range	Init Value	Unit
State	Signals the current state of the internal velocity measurement	0	UNSIGNED 8	0: Init/Off 1: Idle 2: Measure 4: Standby	0	-

Table 8-36: Input data for module 22

Input data length: 1 byte

Output Data

Output Data	Description	Address	Data Type	Value Range	Init Value	Unit
Start event	Event starts velocity measurement	0.0	Bit	0 -> 1: Start	0	-
Stop event	Event stops velocity measurement	0.1	Bit	0 -> 1: Stop	0	-
Min/Max velocity mode	Defines whether the current velocity is included in min/max recording	0.2	Bit	0: Do not record min/max 1: Record min/max	0	-
Min/Max velocity reset	Reset the min/max velocity values	0.3	Bit	0 -> 1: Reset	0	-

Table 8-37: Output data for module 22

Output data length: 1 byte

8.2.24 Module 23: Velocity measurement status

Description

This module supplies various status information regarding the velocity measurement of the BE-90 PB to the PROFIBUS master.

Parameter

none

Input Data

Input Data	Description	Address	Data Type	Value Range	Init Value	Unit
Velocity measurement error	Signals that no valid velocity could be ascertained	0.0	Bit	0: OK 1: Error	0	-
Velocity limit value status 1	Signals that velocity limit value 1 has been exceeded	0.1	Bit	0: No limit value violation 1: Value greater than limit	0	-
Velocity limit value status 2	Signals that velocity limit value 2 has been exceeded	0.2	Bit	0: No limit value violation 1: Value greater than limit	0	-
Velocity limit value status 3	Signals that velocity limit value 3 has been exceeded	0.3	Bit	0: No limit value violation 1: Value greater than limit	0	-
Velocity limit value status 4	Signals that velocity limit value 4 has been exceeded	0.4	Bit	0: No limit value violation 1: Value greater than limit	0	-
Dyn. Velocity limit value status	Signals that the dynamic velocity limit value has been exceeded	0.5	Bit	0: No limit value violation 1: Value greater than limit	0	-
Movement status starting from > 0.01 m/s	Signals whether a movement is currently being detected	0.6	Bit	0: No movement 1: Movement	0	-
Direction of movement	If bit 6 is set, the direction of movement can be read here	0.7	Bit	0: Direction - tape start 1: Direction - tape end	0	-
Velocity limit value status 1	Signals whether the current velocity is compared with this limit value	1.1	Bit	0: Comparison not active 1: Comparison active	0	-
Velocity limit value status 2	Signals whether the current velocity is compared with this limit value	1.2	Bit	0: Comparison not active 1: Comparison active	0	-
Velocity limit value status 3	Signals whether the current velocity is compared with this limit value	1.3	Bit	0: Comparison not active 1: Comparison active	0	-
Velocity limit value status 4	Signals whether the current velocity is compared with this limit value	1.4	Bit	0: Comparison not active 1: Comparison active	0	-
Dyn. Velocity limit value status	Signals whether the current velocity is compared with this limit value	1.5	Bit	0: Comparison not active 1: Comparison active	0	-

Table 8-38: Input data for module 23

Input data length: 2 bytes

Output Data

none

8.2.25 Module 24: Min/Max velocity

Description

The Min/Max velocity function monitors the velocity value and transfers the maximum and minimum value to the PROFIBUS master. Recording can be controlled via module 22 "Velocity measurement control". It is also possible to reset values to the initialization value via module 22.

Parameter

none

Input Data

Input Data	Description	Address	Data Type	Value Range	Init Value	Unit
Minimum velocity	Minimum velocity for detected period	0	UNSIGNED 32	0 ... 10'000'000	0	scaled
Maximum velocity	Maximum velocity for detected period	4	UNSIGNED 32	0 ... 10'000'000	0	scaled

Table 8-39: Input data for module 24

Input data length: 8 bytes consistently

Output Data

none

8.2.26 Module 25: Static velocity limit values

Description

The limit value function compares the current velocity with a limit velocity stored in the configuration. If the value is above or below the limit value, the limit value status in module 23 is set and, if configured, the switching output is appropriately set.

Parameter

Parameter	Description	Rel. Address	Data Type	Value Range	Standard	Unit
Velocity limit value mode	Parameter activates or deactivates limit value checking for Velocity limit value 1, Velocity limit value 2, Velocity limit value 3, Velocity limit value 4, on or off	0 0.0 0.1 0.2 0.3	UNSIGNED 8	for each limit value 0: Limit value not active 1: Limit value activated	0 0 0 0	-
Switching mode	Condition for the signal change of the switching output and the status bits for Velocity limit value 1, Velocity limit value 2, Velocity limit value 3, Velocity limit value 4	1 1.0 1.1 1.2 1.3	Bits	for each limit value 0: Value greater than limit 1: Value less than limit	0 0 0 0	-
Velocity limit value 1	Limit value is compared to the current velocity	2	UNSIGNED 16	0 ... 20000	0	mm/s
Velocity hysteresis 1	Relative offset of switching point	4	UNSIGNED 16	0 ... 20000	0	mm/s
Range start limit value 1	The velocity limit value is monitored beginning at this position	6	SIGNED 32	-10000000 ... 10000000	0	mm
Range end limit value 1	The velocity limit value is monitored up to this position	10	SIGNED 32	-10000000 ... 10000000	0	mm
Velocity limit value 2	Limit value is compared to the current velocity	14	UNSIGNED 16	0 ... 20000	0	mm/s
Velocity hysteresis 2	Relative offset of switching point	16	UNSIGNED 16	0 ... 20000	0	mm/s
Range start limit value 2	The velocity limit value is monitored beginning at this position	18	SIGNED 32	-10000000 ... 10000000	0	mm
Range end limit value 2	The velocity limit value is monitored up to this position	22	SIGNED 32	-10000000 ... 10000000	0	mm
Velocity limit value 3	Limit value is compared to the current velocity	26	UNSIGNED 16	0 ... 20000	0	mm/s
Velocity hysteresis 3	Relative offset of switching point	28	UNSIGNED 16	0 ... 20000	0	mm/s
Range start limit value 3	The velocity limit value is monitored beginning at this position	30	SIGNED 32	-10000000 ... 10000000	0	mm
Range end limit value 3	The velocity limit value is monitored up to this position	34	SIGNED 32	-10000000 ... 10000000	0	mm

Velocity limit value 4	Limit value is compared to the current velocity	38	UNSIGNED 16	0 ... 20000	0	mm/s
Velocity hysteresis 4	Relative offset of switching point	40	UNSIGNED 16	0 ... 20000	0	mm/s
Range start limit value 4	The velocity limit value is monitored beginning at this position	42	SIGNED 32	-10000000 ... 10000000	0	mm
Range end limit value 4	The velocity limit value is monitored up to this position	46	SIGNED 32	-10000000 ... 10000000	0	mm

Table 8-40: Parameters for module 25

Parameter length: 50 bytes

Input Data

none

Output Data

none

8.2.27 Module 26: Dynamic velocity limit value

Description

The velocity limit value function compares the current velocity with a stored velocity within the defined range. If the value is above or below the limit value, the dynamic limit value status in module 23 is set and, if configured, the switching output is appropriately set. Limit value, hysteresis, range start and range end are transferred with the output data of this module by the PROFIBUS master. The transferred values are activated by bit 0.0, i.e. if this bit is set, the BE-90 PB compares the current velocity with the new limit value conditions.

Parameter

none

Input Data

none

Output Data

Output Data	Description	Address	Data Type	Value Range	Init Value	Unit
Limit value control	Controls internal processing of the transferred dynamic limit value parameters	0.0	Bit	0: Do not process 1: Parameter now valid /process	0	-
Switching mode	Condition for the signal change of the switching output and the status bit for dynamic velocity limit value	0.1	Bit	0: Value greater than limit 1: Value less than limit	0	-
Dyn. Velocity limit value	Limit value is compared to the current velocity	1	UNSIGNED 16	0 ... 20'000	0	mm/s
Dyn. Velocity hysteresis	Relative offset of switching point	3	UNSIGNED 16	0 ... 20'000	0	mm/s
Range start dyn. Limit value	The dynamic velocity limit value is monitored beginning at this position	5	SIGNED 32	-10'000'000 ... 10'000'000	0	mm
Range end dyn. Limit value	The dynamic velocity limit value is monitored up to this position	9	SIGNED 32	-10'000'000 ... 10'000'000	0	mm

Table 8-41: Output data for module 26

Output data length: 13 bytes consistently

9 Commissioning

9.1 Measures to be performed prior to the initial commissioning

- Before commissioning, familiarise yourself with the operation and configuration of the device(s)!
- Before switching on, recheck all connections and ensure that they have been properly made.

Loading and Configuration of Modules

Gather the required modules for the PB-90 PB in your PLC software and configure them as necessary. Further information regarding the individual modules is provided in chapter "Profibus" on page 36.

Setting the device address

The device address is set via switches in the modular hood. For setting instructions refer to chapter 7.3 .

- *Set the device address according to the address previously selected in the configuration.*

9.2 Function Test

"Power On"-Test

After connecting the operating voltage, the BE-90 PB performs an automatic "Power On" function test. Subsequently, the green LED lights up in the optics window of the BE-90 PB.

Interface

A red/green LED for checking the interface function is located on the underside of the modular hood. The significance of the individual LED states may be found in **Table 4-2** on page 14.

Problems

Should a problem persist after checking all electrical connections and settings on the devices and host, please contact a TR-Electronic service officer near you (see last page of this operating manual).

10 Maintenance

10.1 General maintenance information

Usually, the barcode positioning system BE-90 PB does not require any maintenance by the operator.

Cleaning

Should it become soiled, clean the glass window of the BE-90 PB with a soft cloth.



Notice!

Do not use aggressive cleaning agents such as thinner or acetone for cleaning the device.

10.2 Repairs, Servicing

Repairs to the device must only be carried out by the manufacturer.

- Contact your TR-Electronic distributor or service organisation should repairs be required. For addresses, please refer to the last page of this operating manual.